

*Panel  
Craft  
Roof System  
Seaming  
Guide*

**Horizon Structural Systems Inc.**

3950 Hwy 46 West #200,  
New Braunfels, TX 78132

830-629-8000

<https://horizonstructural.com>

[info@horizonstructural.com](mailto:info@horizonstructural.com)



**DUE TO THE PROCESS OF CONTINUOUS IMPROVEMENT, THE  
PRODUCTS AND PROCEDURES IN THIS MANUAL ARE SUBJECT TO  
CHANGE WITHOUT NOTICE**

<b>MANUAL REVISION INFORMATION</b>			
<b>ACTIVITY</b>	<b>ADDENDUM RELEASE #</b>	<b>PAGES REVISED</b>	<b>RELEASE DATE</b>
Revised	#1	All	08/31/2018

# Panel Craft Roof System Seaming Guide

NOTES

# Panel Craft Roof System Seaming Guide

## TABLE OF CONTENTS

<b>1.0</b>	<b>General</b> .....	4
1.1	Purpose of this manual.....	4
1.2	Buyer’s responsibility.....	4
1.3	MBMA.....	4
1.4	Disclaimer.....	4
1.5	Receiving and shipping.....	4
1.6	Handling and Storage.....	5
1.7	Insurance.....	5
1.8	Power supply.....	5
1.9	Electrical service and cords.....	5
1.10	Electrical safety and cord clearance.....	5
1.11	Roof performance.....	5
<b>2.0</b>	<b>Importance of Seaming/Hand Crimping</b> .....	6
2.1	When to hand crimp.....	6
2.2	When to seam.....	6
2.3	Specialized seaming tools.....	6
2.4	Crimping/Seaming Requirements.....	7
<b>3.0</b>	<b>Glossary of Terms</b> .....	8
<b>4.0</b>	<b>Finished Seam Types</b> .....	9
4.1	General.....	9
4.2	Horizon RollLok Seam.....	9
4.3	Horizon TripleLok Seam.....	9
4.4	Horizon QuadLok Seam.....	9
4.5	Seam type details.....	10
<b>5.0</b>	<b>Seaming Kit</b> .....	11
5.1	Specialized seaming tools.....	11
5.2	Seaming tool source.....	11
5.3	Seaming kit.....	11
<b>6.0</b>	<b>Assembly</b> .....	13
6.1	Side lap fit-up.....	13
6.2	Clip alignment.....	13
6.3	Seam damage.....	13
<b>7.0</b>	<b>Horizon RollLok/TripleLok Crimper Tools (Buyout items)</b> .....	14
7.1	Stand-up Roll Lock/TripleLok hand crimper.....	14
7.2	Small Roll Lock/TripleLok hand crimper.....	14
<b>8.0</b>	<b>Manual Crimping Tool Operation for Schulte RollLok/TripleLok (Small Crimper)</b> .....	15
8.1	Small hand crimping tool nomenclature.....	15
8.2	Assemble the crimping tool.....	15
8.3	Tool orientation to seam.....	15
8.4	Forming the seam.....	15
8.5	Tool position on the roof panel.....	16
8.6	Checking the finished seam.....	16
<b>9.0</b>	<b>Manual Crimping Tool Operation for Horizon RollLok/TripleLok (Stand-up Crimper)</b> .....	17

# Panel Craft Roof System Seaming Guide

9.1	Stand-up hand crimping tool nomenclature.....	17
9.2	Assemble the stand-up crimping tool.....	17
9.3	Tool orientation to the seam.....	17
9.4	Forming the seam.....	17
<b>10.0</b>	<b>Horizon RollLok Seaming Details.....</b>	<b>18</b>
10.1	Manual seaming.....	18
10.2	Finished seam detail.....	18
<b>11.0</b>	<b>Before Operating the Motorized Seaming Machine.....</b>	<b>19</b>
11.1	Seaming machine nomenclature.....	19
11.2	Single direction TripleLok seamer.....	19
11.3	Flip Flop Seamer (Bi-Directional).....	20
11.4	Cleaning the seams.....	20
11.5	Starting seams.....	20
11.6	Single direction QuadLok seamer.....	21
<b>12.0</b>	<b>Motorized Seaming Machine (TripleLok).....</b>	<b>22</b>
12.1	Manual crimping/seaming.....	22
12.2	Machine orientation to the seam (single directional seamer).....	22
12.3	Machine position on the roof panel.....	22
12.4	Machine orientation to the seam (bi-directional seamer).....	23
12.5	Rotating the bi-directional seamer.....	24
12.6	Machine position on the roof panel.....	25
12.7	Running the machine.....	26
12.8	Unlocking the machine.....	26
12.9	Stopping the machine.....	26
12.10	Checking the finished seam.....	26
<b>13.0</b>	<b>QuadLok Crimper Tools (Buyout Items).....</b>	<b>27</b>
<b>14.0</b>	<b>Manual Crimping Tool Operation for QuadLok (Small Crimper).....</b>	<b>28</b>
14.1	Tool orientation to seam.....	28
<b>15.0</b>	<b>Manual Crimping Tool Operation for Horizon QuadLok (Stand-up Crimper).....</b>	<b>29</b>
15.1	Stand-up hand crimping tool nomenclature.....	29
15.2	Assemble the stand-up crimping tool.....	29
15.3	Tool orientation to the seam.....	29
15.4	Forming the seam.....	29
<b>16.0</b>	<b>QuadLok Seaming Details (Single Pass Operation).....</b>	<b>30</b>
16.1	Locking seamer on panel.....	30
16.2	Motor seaming.....	30
<b>17.0</b>	<b>QuadLok Seaming Details (Double Pass Operation).....</b>	<b>31</b>
17.1	Prior seaming.....	31
17.2	Locking seamer on panel.....	31
17.3	Motor seaming.....	31
17.4	Finished seam detail.....	31
<b>18.0</b>	<b>Motorized Seaming Machine Maintenance.....</b>	<b>32</b>
18.1	General.....	32
18.2	Seaming rolls.....	32
18.3	Cooling vents.....	32
<b>19.0</b>	<b>Seamer Troubleshooting Guide.....</b>	<b>33</b>

# Panel Craft Roof System Seaming Guide

## 1.0 General

### 1.1 Purpose of this manual

This installation manual is provided to Horizon Builders and their erectors as the recommended procedure for the correct seaming of the Horizon Structural Systems (HSS) Panel Craft Roof System.

This manual is intended to be used in conjunction with the Panel Craft Installation Manual and the project's erection drawings to help plan and organize the installation of the HSS Panel Craft Roof System. The erection drawings govern specific seam requirements. **In the case of conflict between this installation manual and the erection drawings, the erection drawings will take precedence.**

### 1.2 Buyer's Responsibility

The buyer must take responsibility for selecting a competent erector, insist that the work be performed by qualified and experienced standing seam metal roof installers, and insist that the erector take time to study and understand this manual, then assure that the erector correctly follows the manual's instructions.

Horizon does not guarantee and is not liable for the quality of the erection. HSS is not responsible for building defects that may be attributed to improper erection or negligence of other parties.

Clarification concerning the HSS Panel Craft roof installation should be directed to the Horizon Structural Systems Customer Service Department. The following is a list of addresses and phone numbers for the customer service representative at each division:

Horizon Structural Systems Inc.

3950 Hwy 46 West #200,  
New Braunfels, TX 78132

830-629-8000

<https://horizonstructural.com>

[info@horizonstructural.com](mailto:info@horizonstructural.com)

### 1.3 MBMA

This building is designed, manufactured and delivered in accordance with the 2006 M.B.M.A. (Metal Building Manufacturer's Association) metal Structural Systems manual. Consult the information in the "Common Industry Practices" section for more information.

### 1.4 Disclaimer

**THE PRODUCTS AND PROCEDURES IN THIS MANUAL ARE SUBJECT TO CHANGE WITHOUT NOTICE.**

### 1.5 Receiving and Shipping

Upon receipt of the seaming kit, and before the signing of the shipping receipt, check and verify that the seaming kit is received in good condition, without damage or loss of contents. See section 5.0 for a list of kit contents.

If there is damage or loss of contents, immediately file the claim with the shipper and notify the seamer supplier or HSS for replacement instructions.

**Upon completion of seaming the roof, promptly return the seaming kit to the seamer supplier in accordance with the instructions on the return shipping documents. The return shipping documents are included in the seaming kit.**

# Panel Craft Roof System Seaming Guide

## 1.6 Handling and Storage

Provide safe and secure handling of the seaming tools when in use.

The motorized seaming machine weighs 65-pounds, and can cause severe injury and damage if it falls.

The machine is too heavy to safely carry up a ladder. Always hoist the machine onto the roof with proper lifting equipment and securely tied to the machine's front lifting handle.

When starting and stopping the seaming machine at the edges of the roof, the operator must be securely positioned so they can safely lift the machine on and off of the panel seam.

**Caution:** When running the machine in the downslope direction, the machine will have greater downhill inertia and coasting distance.

When not locked to the panel seam, the motorized seaming machine can freely roll on its wheels. Always secure the machine to prevent it from rolling or sliding off of the roof.

When the seaming tools are not in use, they must be stored in the seaming kit chest and in a safe and dry area. The seaming tools **MUST** be cleaned and dried before storing.

## 1.7 Insurance

The HSS seaming tools are custom built specialized equipment and are costly to replace. Provide adequate insurance coverage on the seaming tools while they are in your possession.

## 1.8 Power Supply

The seaming machine motor requires a minimum electrical power supply of:  
20 amps @ 120 volt @ 60 hz. AC.

## 1.9 Electrical Service and Cords

The electrical service and cords to the seaming machine **MUST** be of sufficient capacity to provide the full 20-amps @ 120-volts **AT THE SEAMING MACHINE**. If other tools or equipment are being used on the same service, the service and cord capacity **MUST** be increased accordingly.

**IMPORTANT NOTE: Low voltage due to insufficient service capacity, insufficient cord size or excessive cord length will cause overheating and burnout of the seaming machine's motor.**

### Cord Requirements for proper voltage chart

Distance (Ft.)	0-50	50-100	100-200	200-300
wire				
Gauge(AWG)	12	10	8	6

## 1.10 Electrical Safety and Cord Clearance

Check that the power cords are fitted with the correct plug for safe and secure connection to the seaming machine. Check that the power cords are properly grounded and that the service has a ground fault circuit breaker.

Check that the electrical cord is of sufficient length to extend the full length of the area to be seamed, without stress on the cord or its connections. Check that the path for the cord is clear and that the cord is clear of snagging on panel edges or entanglement onto the seaming machine rolls.

## 1.11 Roof Performance

The roof panels **MUST** be correctly installed, hand crimped, and seamed before the roof system can provide its designed wind load and weather resistance capability. This means that an un-seamed roof is subject to wind load failure. **The erector shall be responsible to ensure that the proper seaming method is followed (Either Horizon RollLok, TripleLok, or QuadLok).**

# Panel Craft Roof System Seaming Guide

## 2.0 Importance of Seaming/Hand Crimping

### 2.1 When to Hand Crimp

As work progresses, the erector ***is required*** to hand crimp the panels at the low eave, each panel clip, each end lap and high eave/ridge end of the panels. Utilize the proper hand crimper to accomplish this RollLok profile.

Hand crimping the entire roof into a finished RollLok seam, will suffice in ***temporarily securing the roof panel until the proper finished seam can be completed***. Also, hand crimping at the required locations ***is required*** PRIOR to motor seaming of the roof panel.

### 2.2 When to Seam

Whenever possible, the installed roof panels should be seamed at the completion of each day's work. If high winds or rain/snow conditions are imminent, the installed roof panels must be seamed before such conditions occur.

Refer to the project erection drawing **ROOF SHEETING PLAN(S)** and/or **DETAIL PAGE(S)** to determine what seaming option is required. The detail on the next page is a copy of the detail that will appear on the erection drawings. **NOTE:** This detail conveys the **MINIMUM** seaming requirements based on the design of the project. Additional seaming may be necessary as specified by the builder. **ALSO NOTE: Multiple seaming types may be required on a project. Review the roof sheeting plan(s) and detail(s) carefully. Multiple seam types means that you could have two different seamers each producing a different seam profile. See page 11 defining seam types.**

## 2.3 Specialized Seaming Tools

On roofs requiring the TripleLok or QuadLok seams, it may not always be practical or feasible to motor seam the roof panels until after the roof installation is completed. Motor seamed roof panels are difficult to reposition or replace. Motorized seaming machines may not always be available during the entire roof installation period.

In such cases, it may be desirable to temporarily RollLok (hand crimp) the roof panels with the manual seaming tool. Then later complete the seaming with the motorized seaming machine.

**IMPORTANT: It shall be the erector's responsibility to apply the RollLok seaming method in such a way as to ensure that the panels have been adequately secured until the motor seaming can occur.**

# Panel Craft Roof System Seaming Guide

2.4

## Panel Craft CRIMPING/SEAMING REQUIREMENTS

THE DESIGN OF THIS STRUCTURE REQUIRES THAT THE FOLLOWING SEAMING METHOD BE UTILIZED:

1.  Roll Lock Seam
2.  TripleLok Seam
3.  QuadLok Seam

NOTE 1: Additional seaming may be necessary as specified by the builder.

NOTE 2: Multiple seaming types may be required. Review the roof seaming plan(s) carefully for seaming requirements.

NOTE 3: NOT all roof systems require mechanical seaming. The buyer, owner, or architect may elect to specify a mechanically seamed panel. Often, factory mutual ratings also require a QuadLok mechanical seamer.

SEE THE Panel Craft SEAMING MANUAL FOR IMPORTANT ERECTOR INFORMATION ABOUT QUADLOK SEAMER REQUIREMENTS.

### **When to crimp/seam**

As work progresses, it shall be the erector's responsibility to apply the RollLok hand crimping method in as required to ensure that the panels have been adequately secured until mechanical seaming can occur.

Whenever possible, the installed roof panels should be mechanically seamed as work progresses OR at the completion of each day's work. If high winds or rain/snow conditions are imminent, the installed roof panels must be seamed before such conditions occur.

Refer to the project erection drawing roof seaming plan and/or detail pages to determine what option is required. The above detail conveys the MINIMUM seaming requirements based upon the design of the project. Additional seaming may be required on a project. Review the roof seaming plan(s) and details.



# Panel Craft Roof System Seaming Guide

## 3.0 Glossary of Terms:

Below is a list of terms and nomenclature used within this manual to describe hand crimping and seaming operations.

**Panel Seam** – Male and female panel corrugation properly hooked together over a clip within a roof system.

**Finished Panel Seam** – A seam that has been completely or partly hand crimped OR motorized seamed into a RollLok, TripleLok or QuadLok profile seam.

**RollLok Seam** – A finished seam that has had a series of *single* hand crimps at the low eave, each clip, end lap and high eave/ridge of each panel with a RollLok/TripleLok hand crimper.

**Manual Seaming** – The crimping of a panel by use of a hand crimper.

**Temporary Crimping** – A finished RollLok seam.

**Motor/Mechanical Seaming** – Seaming the panel by use of an electric panel seamer.

**TripleLok Seam** – A finished seam that has been hand crimped *continuously* with a TripleLok hand crimper OR motorized seamed with a TripleLok seamer.

**QuadLok Seam** – A finished seam that has been hand crimped *continuously* with a QuadLok hand crimper OR motorized seamed with a QuadLok seamer.

**Single Pass QuadLok Seamer Operation** – A single seamer that is setup to form a Roll Lock seam into a QuadLok seam in one pass. (One direction ONLY)

“**The Answer**” – The seamer suppliers name for a single pass QuadLok seamer.

**Double Pass QuadLok Seamer Operation** – Two separate seamers are required. One is set-up for the TripleLok seam and the second seamer is set-up for the QuadLok seam. (One direction only on the second seamer)

**Primary Seamer** – This is the first seamer in a double pass seaming operation and is set-up to produce a TripleLok seam.

**Secondary Seamer** – This is the second seamer in a double pass seaming operation and is set-up to produce a QuadLok seam.

**Single Directional Seamer** – A seamer that completes a finished seam in a single direction.

**Flip-flop Seamer (Bi-Directional)** – A seamer that has two sets of tooling that runs two directions.

This seamer can be set-up to have TripleLok tooling on **both** sides of the machine, allowing it to TripleLok a seam in one direction, then being flipped over and placed on the next seam over to run back the other direction, producing another TripleLok seam.

This seamer can be set-up to have one side of the tooling set-up for TripleLok and the other side of the tooling set-up for QuadLok. This type of seamer will run one direction producing a TripleLok seam. Then it can be flipped over and placed back on the *same* TripleLok seam and ran back on the seam to the beginning thus producing a QuadLok 360 seam.

# Panel Craft Roof System Seaming Guide

## 4.0 Finished Seam Types

### 4.1 General

The HSS Panel Craft roof system has three seam type options. The project design and performance requirements govern which finished seam type is required.

Different finished seam types may be required on specific areas of the roof. In all cases, refer to the erection drawings to determine the required seam type and locations.

### 4.2 RollLok Seam

The RollLok seam requires the roof panels be crimped with the manual seaming tools at the panel clips, low eave, high side of the roof panels, and at the end laps. This is **required** to be completed as the roof is being installed or by the end of each work day.

The single hand crimp forms the seam into a TripleLok profile.

The motorized seaming machine **MUST** have these locations hand crimped **before** it is placed into operation.

### 4.3 TripleLok Seam

The TripleLok seam requires crimping the roof panels with the manual seaming tool at the panel clips, low eave, high side of the roof panels, and at the end laps. Then seaming the full length of the roof panels with the motorized seaming machine.

#### NOTE:

A TripleLok seam can be *achieved* by **continually** hand crimping the roof panel lap with the correct hand crimper.

### 4.4 QuadLok Seam

#### Single pass QuadLok seamer operation

This is a single seamer that is set-up to form a RollLok seam into a QuadLok seam in one pass.

#### Double pass QuadLok seamer operation

This will require the use of two seamers. The primary seaming tool will form the TripleLok seam and then the secondary seaming tool will form the QuadLok.

This seaming method requires that the roof panels be previously seamed to the TripleLok seam profile. Then over-seaming the full length of the roof panels with the motorized seaming machine.

To start the QuadLok seamer, the previously TripleLok panel seam will need to be manually crimped with the QuadLok hand crimper. (Just to start the seamer) See pages 27-30 for instructions.

#### NOTE:

A QuadLok seam can be *achieved* by **continually** hand crimping the TripleLok seam with the QuadLok hand crimper.

#### SEE THE FOLLOWING PAGE FOR DETAILS OF ALL THREE SEAM TYPES.

# Panel Craft Roof System Seaming Guide

## 4.5 Seam Type Details

The Panel Craft Standing seam roof system has three seam type options. The project's design and roof performance requirements govern which seam type is required.

### RollLok Seam

The RollLok Seam requires seaming the roof panels with the manual seaming tool only at the panel clips, at the eave and ridge ends of the roof panel, and at the endlaps.

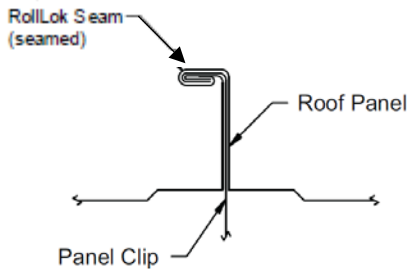

Different seam types may be required on specific areas of the roof. In all cases, refer to the erection drawings to determine the required seam type and location.

The motor seaming machine is not required for RollLok seaming.

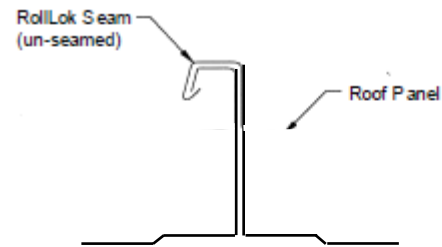

BETWEEN PANEL CLIPS & PANEL ENDS

### TripleLok Seam

The TripleLok Seam requires seaming the roof panel with the manual seaming tool at the starting eave or ridge end of the roof panel and at the endlaps. Then seaming the full length of the roof panels with the motor seaming machine.

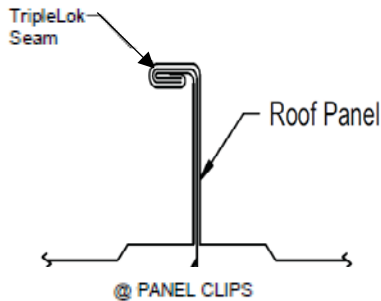

The motor seaming machine must be fitted with the TripleLok seaming rolls.

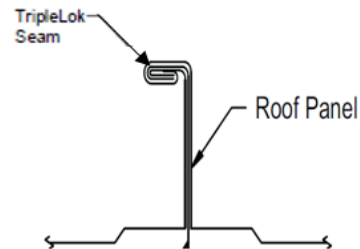

BETWEEN PANEL CLIPS

### QuadLok Seam

The QuadLok Seam requires that the roof panels be previously TripleLok seamed. Then re-seaming specified areas of the roof with the motor seaming machine.

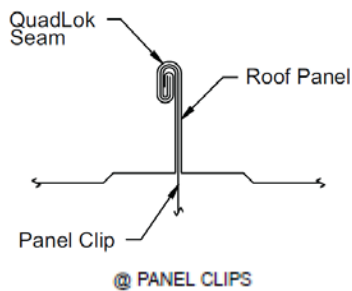

The motor seaming machine must be fitted with the QuadLok seaming rolls.

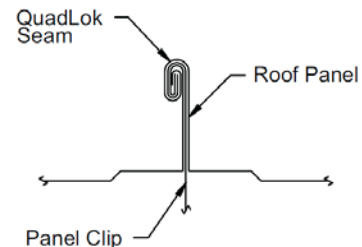

BETWEEN PANEL CLIPS

# Panel Craft Roof System Seaming Guide

## 5.0 Seaming Kit

### 5.1 Specialized Seaming Tools

The seaming of the HSS Panel Craft roof panels requires special seaming tools that are available only from HSS.

**CAUTION:**

**THE USE OF ANY OTHER SEAMING EQUIPMENT WILL RESULT IN FAULTY AND/OR DAMAGED SEAMS AND SHALL INVALIDATE THE ROOF SYSTEM'S MATERIAL AND WEATHER TIGHTNESS WARRANTIES.**

### 5.2 Seaming Tool Source

The seaming tools are provided by HSS in accordance with the terms and conditions of the HSS contract documents. Contact the HSS Customer Services Department to arrange the scheduling, delivery and return of the seaming tools.



Shipping Container



Small TripleLok Hand Crimper  
(Included in the Seamer Kit)



Small QuadLok Hand Crimper (Included  
in the Seamer Kit)

## 5.3 Seaming Kit

The seaming equipment will normally be provided as a seaming kit. The seaming kit will include the following:

- Seaming kit chest (contains and protects the seaming tools during shipment and storage).
- Manual crimping tool(s)
- Motorized seaming machine (provided only for HSS seaming applications).
- Seaming instructions manual
- Return shipping documents
- Small tool kit which includes; miscellaneous wrenches, replacement fiber backer rollers and cam rollers.



Single Directional Motorized Seaming  
Machine (Produces a TripleLok Seam)

# Panel Craft Roof System Seaming Guide

Seaming Kit Continued



**Bi-directional Motorized Seaming Machine**  
Produces a TripleLok Seam  
(TripleLok Tooling on BOTH sides)



**Single Directional Motorized Seaming Machine**  
Produces a QuadLok Seam  
(For a Two Pass Operation)

# Panel Craft Roof System Seaming Guide

## 6.0 Assembly

### 6.1 Side Lap Fit-up

Before seaming, inspect the full length of each roof panel side lap. Check that the lip at the panel's male edge is enclosed by the hook of the adjacent panel's female edge. Refer to the detail below.

Any conditions where the male lip is not positioned inside of the female hook MUST be corrected BEFORE attempting to seam the roof panels.

**CAUTION: False seaming may occur where the female lip does not hook the roof panel's male edge. False seamed roof panels cannot provide their designed load and weather resistance.**

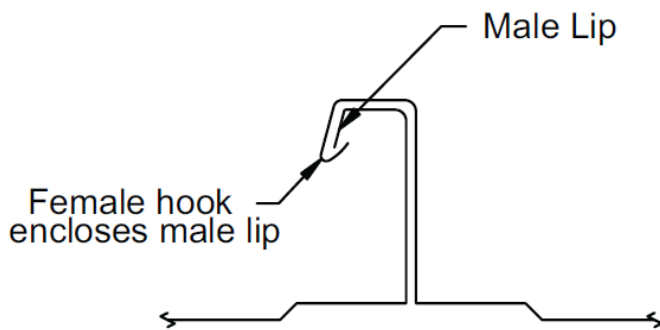

Correct

### 6.2 Clip Alignment

Before seaming, check that each roof panel clip is properly seated in the roof side lap assembly. Any displaced clips MUST be corrected BEFORE attempting to seam the roof panels.

**CAUTION: Panel clips that are not properly aligned can cause faulty seaming and objectionable seam appearance.**

### 6.3 Seam Damage

Before seaming, check that the male and female edges do not have kinks or other distortions. Any such distortions MUST be corrected BEFORE attempting to seam the roof panels.

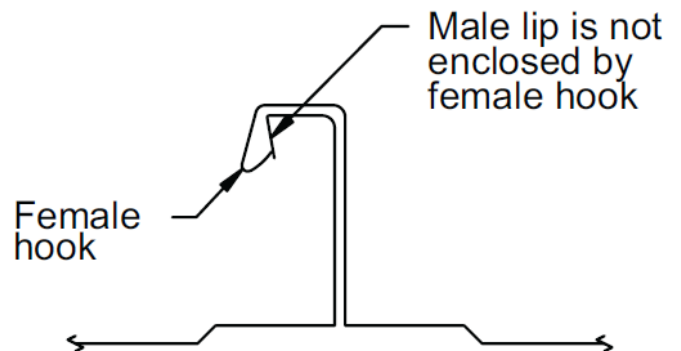

Wrong  
(false seamed)

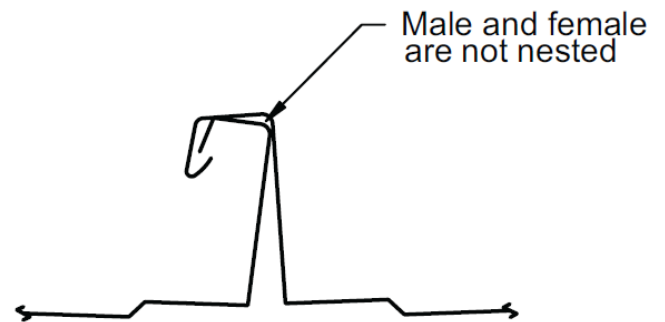

Wrong  
(not nested)

## Panel Craft Roof System Seaming Guide

### 7.0 RollLok/TripleLok Crimper Tools (Buyout Items)

#### 7.1 Stand-up RollLok/TripleLok Hand Crimper

Per the order documents, your job may have one or more of these crimpers.



Stand-up RollLok/TripleLok Hand Crimper

#### 7.2 Small RollLok/TripleLok Hand Crimper

Per the order documents, your job may have one or more of these crimpers. This crimper is useful for one person erecting the low eave, end laps, high eave ends of the panels and during roof curb installations.



Small RollLok/TripleLok Hand Crimper

# Panel Craft Roof System Seaming Guide

## 8.0 MANUAL CRIMPING TOOL OPERATION FOR THE ROLLOK/TRIPLELOK SMALL CRIMPER

### 8.1 Small Hand Crimping Tool Nomenclature

The detail below identifies the operational parts of the small hand crimping tool.

**This hand crimper manually forms a finished TripleLok seam if used continuously.**

### 8.2 Assemble the Crimping Tool

When received, the crimping tool may be disassembled. Assemble the handle to the tool body with the provided bolts.

### 8.3 Tool Orientation to Seam

Orient the tool to fit correctly onto the roof panel seam as shown in Step 1 below. The stationary handle **MUST** be in the horizontal position and the operating handle **MUST** be rotated up to the open position.

### 8.4 Forming the Seam

When the tool is correctly positioned on the panel, push the stationary blade solidly against the top of the seam.

While holding the stationary handle in the horizontal position, rotate the operating handle down to the horizontal position as shown in Step 2. This will form the seam into a *single* TripleLok crimp.

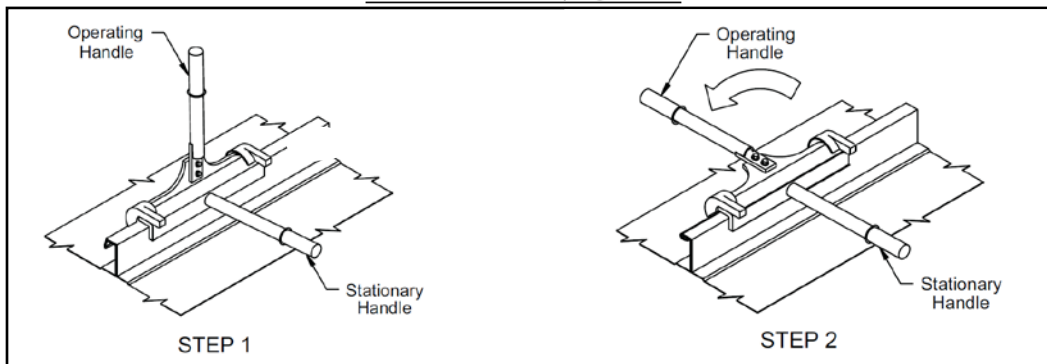
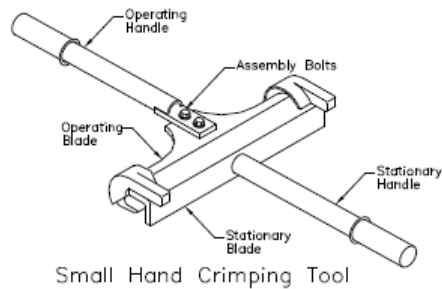

**NOTE:** A Short-Handled Crimping Tool is shown here and on the following pages for Clarity.

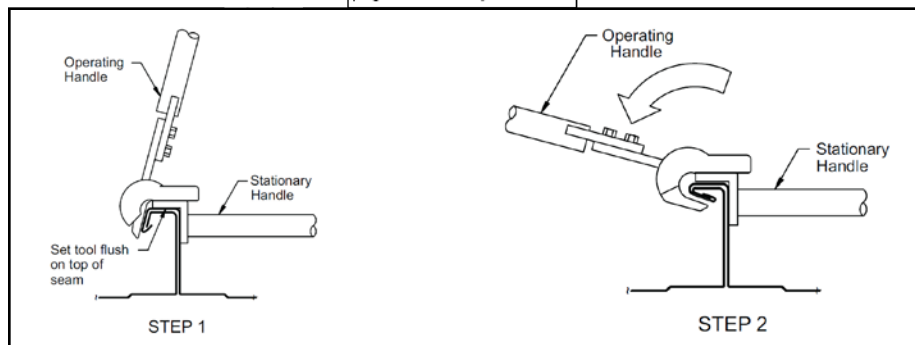



# Panel Craft Roof System Seaming Guide

## 8.5 Tool Position on the Roof Panel

When hand crimping at the low eave, ridge end, end lap and **ALL** roof clip locations, the crimping **MUST** be done in two steps.

**Step 1:** Position the crimping tool as shown below in the various areas of the roof. Rotate the moveable handle down to form a single TripleLok crimp. Release the handle.

**Step 2:** Re-position the crimping tool as shown below and repeat Step 1.

## 8.6 Checking the Finished Seam

Rotate the operating handle to the open position, remove the tool and check that the seam is correctly formed, as shown below.

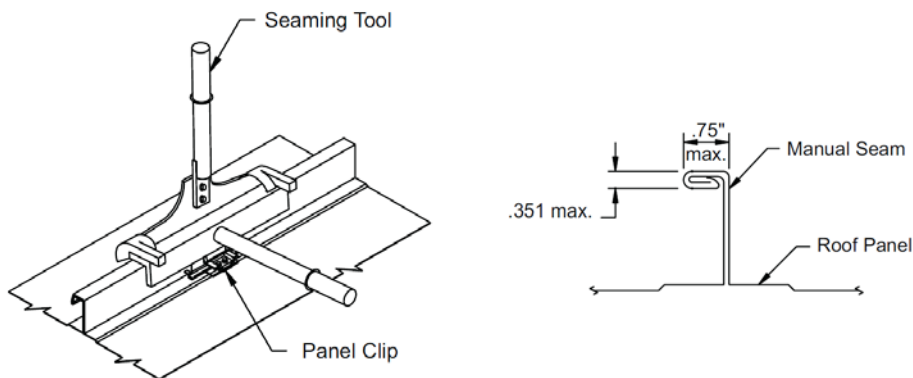
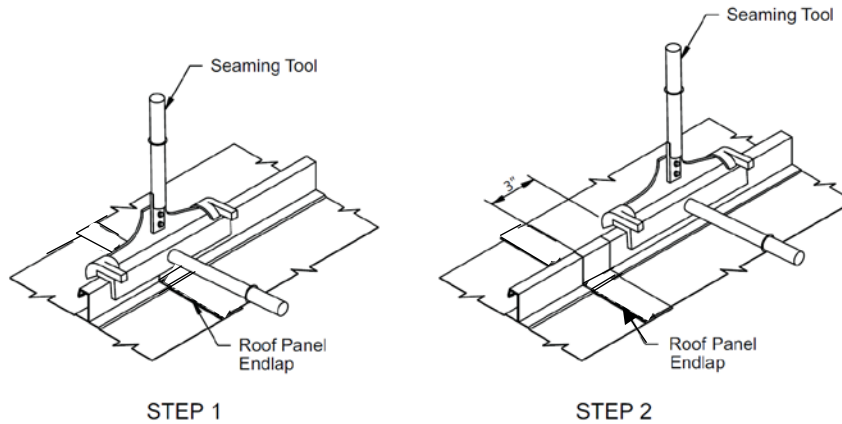
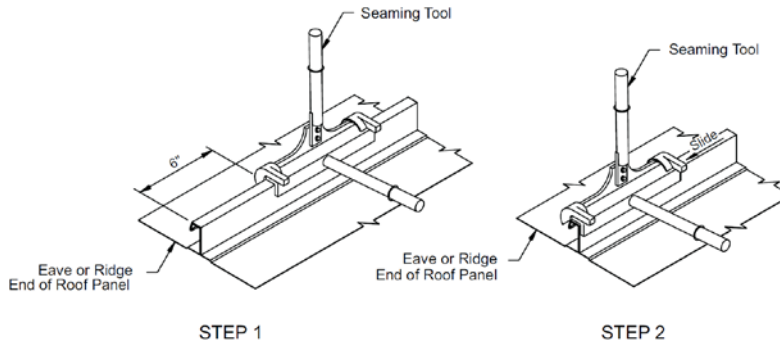

@ PANEL CLIPS

## Panel Craft Roof System Seaming Guide

### 9.0 MANUAL CRIMPING TOOL OPERATION FOR THE ROLLOK/TRIPLELOK STAND-UP CRIMPER

#### 9.1 Stand-up Hand Crimping Tool Nomenclature

The detail below identifies the operational parts of the stand-up hand crimping tool.

#### 9.2 Assemble the Stand-up Crimping Tool

When received, the crimping tool may be partially disassembled. Assemble the handle to the push rod with the provided lock pins.

#### 9.3 Tool Orientation to the Seam

Orient the tool to fit correctly onto the roof panel seam as shown in Step 1 below. The stationary handle **MUST** be in the vertical position and the operating handle **MUST** be rotated to the open position.

### 9.4 Forming the Seam

The tool is correctly positioned on the panel seam when the operating handle is UP and the stationary shoe is pushed firmly DOWN against the top of the seam.

While holding the stationary handle vertical, rotate the operating handle DOWN to the position as shown in Step 2. This will form the seam into a *single* TripleLok shaped crimp.

#### NOTE:

This hand crimper manually forms a finished RollLok seam and if used continuously, will form a finished TripleLok seam.

#### CAUTION:

**The crimper or seam could be damaged if the stationary shoe is NOT COMPLETELY down on the seam.**

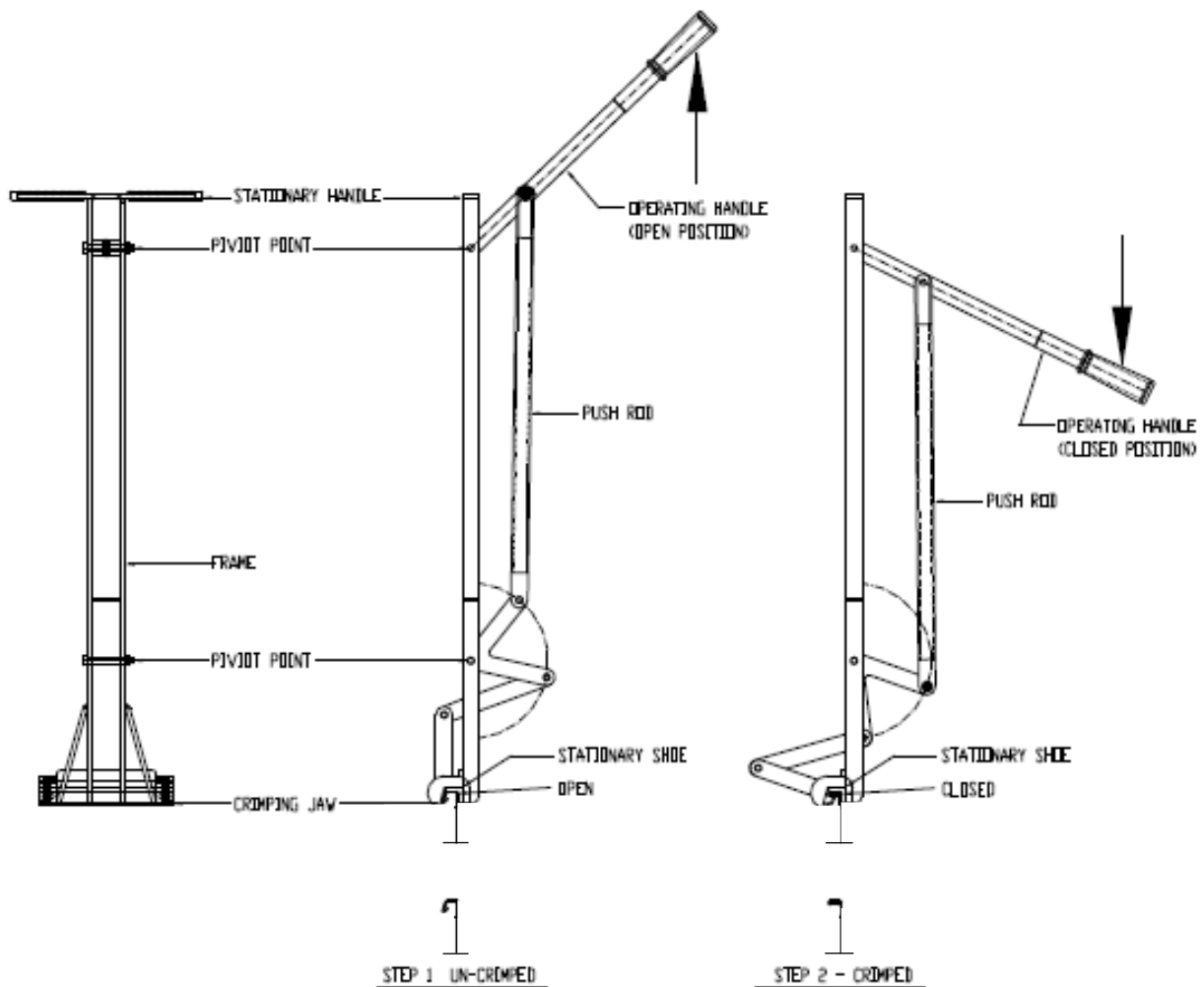

# Panel Craft Roof System Seaming Guide

## 10.0 ROLLOK SEAMING DETAILS

### 10.1 Manual Seaming

The RollLok seam requires the roof panels be crimped with the manual seaming tools at the panel clips, low eave, high side of the roof panels, and at the end laps.

### 10.2 Finished Seam Detail

Check that the finished seam is correctly formed as shown in the detail below.

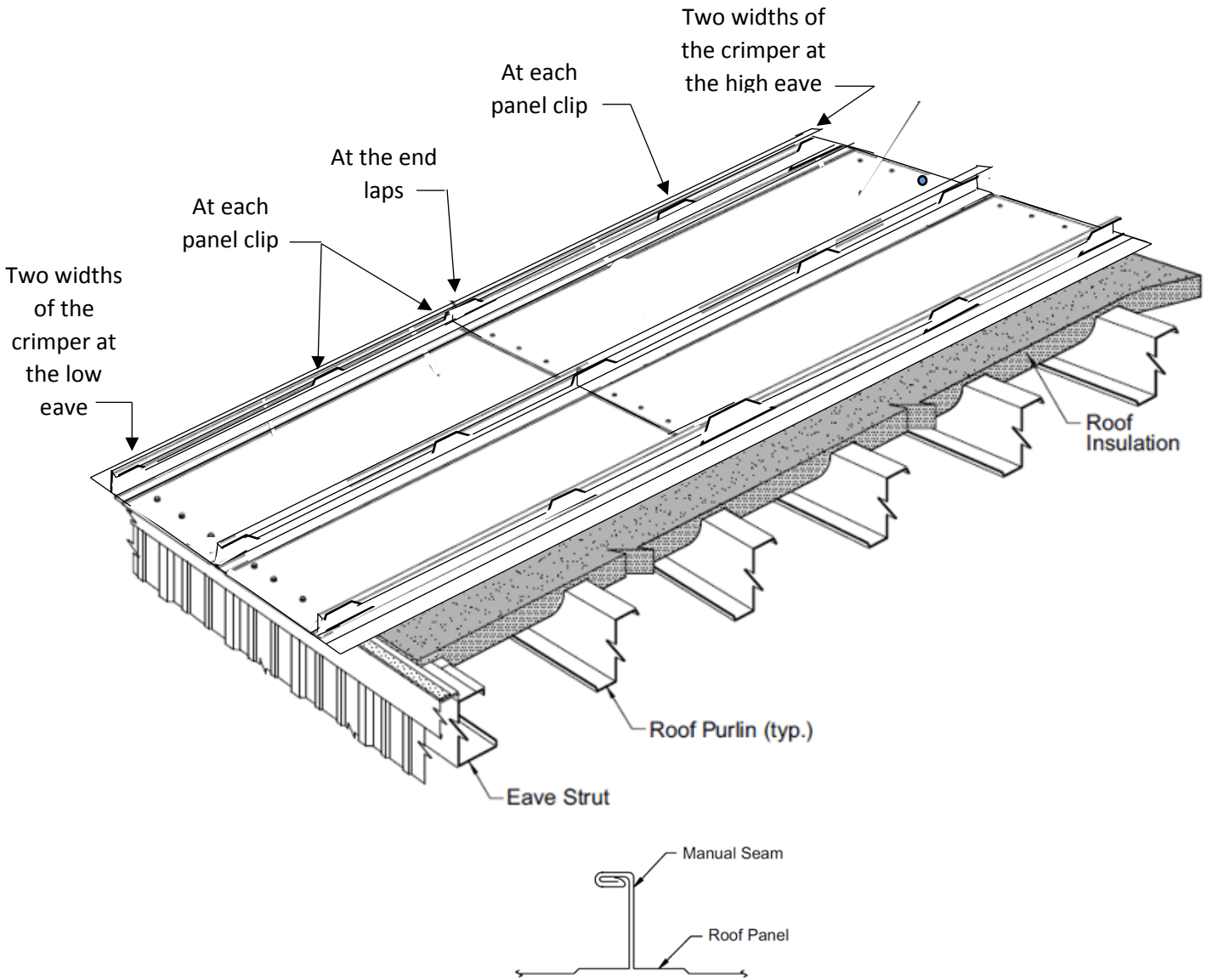

# Panel Craft Roof System Seaming Guide

## 11.0 BEFORE OPERATING THE MOTORIZED SEAMING MACHINE

### 11.1 Seaming Machine Nomenclature

The following pages identify the operational parts of different motorized seaming machines. Familiarize yourself with the supplied seamer prior to operation. Seaming tools may have slight variations from the tools shown in this manual.



### 11.2 Single Direction TripleLok Seamer

With a single directional TripleLok seamer, it should be clearly labeled "PRIMARY" on the tool with arrows indicating the direction of travel. (see below)

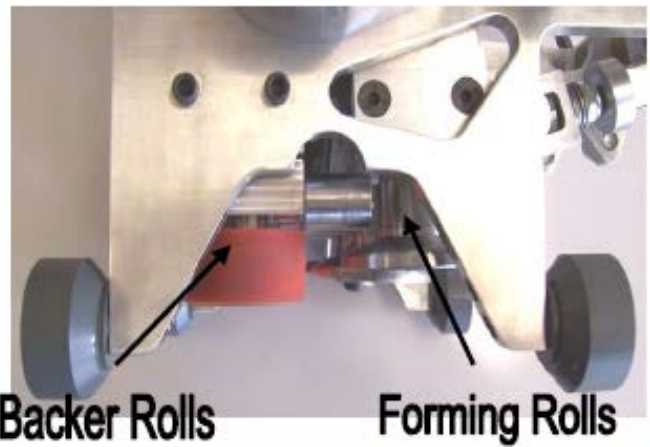

IF excessive picking of the paint or Galvalume coating is occurring, then discontinue seaming and consult with your HSS customer service representative or your seamer supplier representative. Failure to contact either representative may void your roof warranty.



Primary Seamer  
Produces a TripleLok Seam

## Panel Craft Roof System Seaming Guide

### 11.3 Flip Flop Seamer (Bi-Directional)

This seamer machine has two sets of forming rollers on one machine. This tool can be started at the peak or the eave. Arrows indicate the direction of travel. Once the seamer machine has finished TripleLoking a seam, un-lock the machine from the seam, then pull up on the release trigger pin located under the handle. Rotate the machine until the machine trigger pin locks into position once the machine has been rotated. Next, lock the seamer on the next seam adjacent to the one that was just seamed.

**MAKE SURE THAT THE SEAMER ARROW POINTS IN THE DIRECTION OF THE PANEL THAT IS TO BE SEAMED.** Double check that the rollers are properly placed on the panel seam as shown in Sections 12.4-12.6. Seam the panel and then repeat the prior steps on the next seam.

### 11.4 Cleaning the Seams

The roof panel seams **MUST** be thoroughly cleaned of abrasive dirt or dust that can cause scuffing or scratching of the seam surface. The roof panel seams **MUST** be cleaned of grease and **ALL** other contaminants that can cause the seaming machine slippage and marking of the seam surface.

### 11.5 Starting Seams

For the TripleLok seaming, the seaming machine **MUST** start on a finished RollLok seam that has already been crimped with the manual crimping tool. Depending on which direction the seaming machine will run, form the starting seam at the eave or ridge end of the panels with the manual seaming tool as described previously in Sections 7.0-9.0.

#### NOTE:

**IF excessive picking of the paint or Galvalume coating is occurring, then discontinue seaming and consult with your HSS customer service representative or your seamer supplier representative. Failure to contact either representative may void your roof warranty.**



## Panel Craft Roof System Seaming Guide

### 11.6 Single Direction QuadLok Seamer

Used in the double pass QuadLok operation.

The QuadLok seam requires one three station OR one four station single direction motorized seaming tool. These tools will be clearly labeled “**Primary**” and “**Secondary**” with arrows indicating the direction of travel.

**The Primary seaming tool MUST be run on ALL panels BEFORE the Secondary seaming tool is operated.**

### Secondary Seamer



### Single Directional Motorized Seaming Machine

**Produces a QuadLok Seam**



## Panel Craft Roof System Seaming Guide

### 12.0 MOTORIZED SEAMING MACHINE (TRIPLELOK)

#### 12.1 Manual Crimping/Seaming

The TripleLok seam requires prior hand crimping of the roof panel with the manual seaming tool at ALL panel clips, low eave, high side of the roof panels, and at the end laps. Then seaming the full length of the roof panels with the motorized seaming machine.

#### 12.2 Machine Orientation to the Seam (Single Directional Seamer)

On roofs sheeted from **left to right, the seaming machine will run from the eave to the ridge.**

On roofs sheeted from **right to left, the seaming machine will run from the ridge to the eave.**

### 12.3 Machine Position on the Roof Panel

#### NOTE:

Prior to running the seamer, make sure a safety cable is attached to the seamer.

With the locking handles down in the open position, set the seaming machine onto the starting end of the roof panel's seam, over the manually seamed portion of the seam.

Roll the seaming machine forward to align the front seaming rolls over the unseamed portion of the seam, as shown in the details below.



**Seamer Locked on the  
Manually Crimped VR16 II panel**



**Unlocked  
Handles Down**

**Note the Orientation of the Seamer  
and Locking Handles**



**Locked  
Front Two  
Handles Up**



**Seamer Locked on  
the Adjacent Seam**

## Panel Craft Roof System Seaming Guide

### 12.4 Machine Orientation to the Seam (Bi-Directional Seamer)

With this example below, the Flip-Flop seamer produces a TripleLok seam in **both** directions. When using the Bi-Directional seamer, it doesn't matter which direction that the roof was sheeted. The seamer will run from eave to ridge OR ridge to eave.

Basically, you run the seamer up one seam, release the trigger pin next to the handle, rotate the machine, then place it on the adjacent un-seamed seam and run the seamer back.

**The Seaming Direction is Indicated by Arrows on the Motor.**



**Step #1**

With the locking handle held up in the open position, set the seaming machine onto the starting end of the roof panel's seam, over the manually crimped portion of the seam.



**Step #2**

Lock the seamer onto the panel by pushing the handle outward.

Shown is the TS-324 Panel for example only

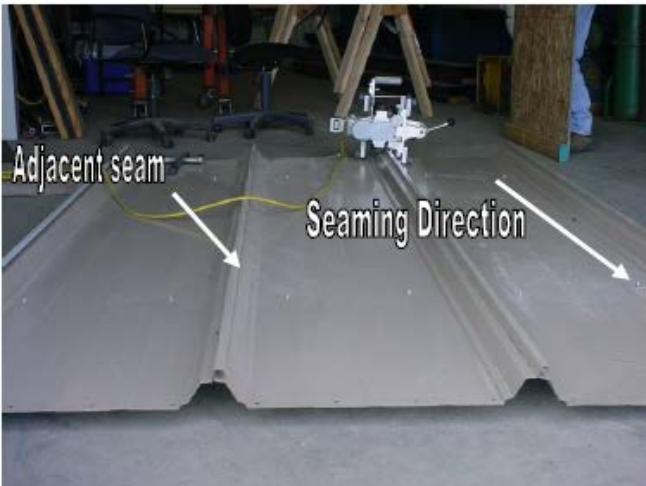

**Step #3**

Make sure the arrow on the seamer points in the direction that you are seaming.

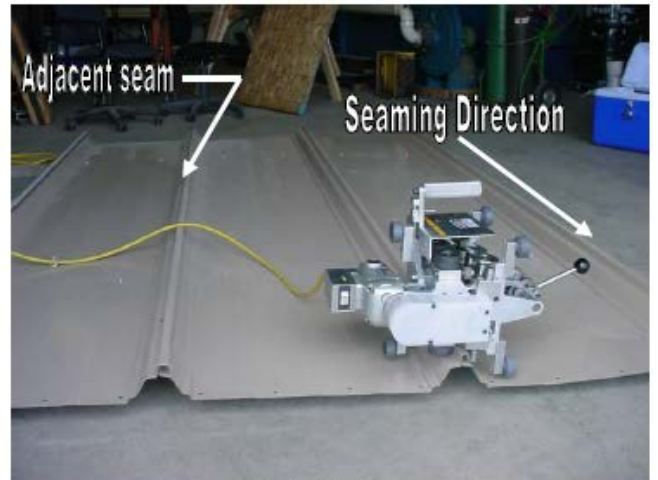

**Step #4**

Run seamer to the end of the panel.



## Panel Craft Roof System Seaming Guide

### 12.5 Rotating the Bi-Directional Seamer



**Step #5**

Next, un-lock the seamer from the panel seam. Pull up on the trigger pin next to the handle.



**Step #6**

Rotate the seamer 180°, allowing the trigger pin to latch.



**Step #7**

The seamer fully rotated.

# Panel Craft Roof System Seaming Guide

## 12.6 Machine Positioning on the Roof Panel



**Step #8**

Place rotated seamer on the adjacent seam. Lock onto manually crimped area of the panel.

Shown is the TS-324 Panel for example only



**Step #9**

Seamer ran back to starting point on the adjacent seam. Repeat steps 1-9 along the panel run

## Panel Craft Roof System Seaming Guide

### 12.7 Running the Seaming Machine

Check that the machine's path is clear of power cords, tools, debris, etc.

Start the machine by turning on the machine's toggle switch.

When running the seamer, the operator should look ahead of the seamer for any damaged seams or un-engaged panels. If the operator sees damaged and/or un-engaged panels, then the operator should stop the machine and fix the problem area **BEFORE** continuing. **FAILURE** to repair such areas and then running the seamer over them could cause the seam to become **un-repairable**.

Watch the machine and the finished seam carefully for any indication of the machine malfunctioning or faulty seaming.

#### CAUTION:

- Check that **ALL** seams have been properly hand crimped **PRIOR** to motor seaming.
- **STOP** the machine immediately, and investigate any indications of machine malfunction or faulty seaming.
- It is recommended **NOT** to run the seamer over panel end laps. The end laps should be hand crimped for proper finished seam.
- **Do not** run the machine into previously installed outside closures, roof curbs or other obstructions.
- **Do not** run the machine over damaged seams or un-hooked panels.
- **Do not** walk or stand on the panel NEXT to the machine while it is running.
- The seaming machine **MUST ALWAYS** be in the vertical position while seaming. **Do Not** allow the machine to tilt sideways when locking the machine onto the seam or while the machine is running. On roofs with tall clips, walking or standing on the panel next to the machine can deflect the panel and cause the machine to tilt.
- Prior to running the seamer, secure the machine to a proper lanyard and anchoring system.

### 12.8 Unlocking the Machine

After the machine is turned off and has fully stopped, release the locking handle to the open position. With the locking handle released, the machine can be lifted from the seam.

If the machine must be stopped and removed before completing the seam, use a felt marker to mark the position of the machine's front wheel on the panel. The machine can later be repositioned on the mark to complete the seaming.

### 12.9 Stopping the Machine

Stop the machine by turning off the machine's toggle switch.

**ALWAYS** allow sufficient space for the machine to coast after turning it off.

### 12.10 Checking the Finished Seam

At the completion of each seam, check the full length of the seam for any false seaming or distortions. Refer to Sections 10.2, 12.3, & 17.4 for details of correctly formed finished seams.

#### NOTE:

**Seaming options vary from project to project. Refer to the project erection drawings for specific seaming requirements for your project.**



**Finished TripleLok Seam Profile**

## Panel Craft Roof System Seaming Guide

### 13.0 QUADLOK CRIMPER TOOLS (BUYOUT ITEMS)



Small QuadLok Hand Crimper



Stand-up QuadLok Hand Crimper



Open Crimping Jaw of the QuadLok Crimper



## Panel Craft Roof System Seaming Guide

### 14.0 MANUAL CRIMPING TOOL OPERATION FOR THE QUADLOK (SMALL CRIMPER)

#### 14.1 Tool Orientation to Seam

Next is the process of manually crimping the panel rib into a 360° seam profile. Before you attempt the QuadLok hand crimper: check and see if you have a good tight TripleLok seam. If not, then go over the area with a TripleLok hand crimper and re-crimp. It is **important** to manually crimp a single QuadLok crimp **PRIOR** to locking on and running the QuadLok seamer.

Start by placing the open 360° crimper on top of the previously TripleLoked panel rib and **between** a roof clip. Make sure that the flat side of the crimper is on the panel rib shoulder and the crimper hook is under the female lip.

Note the angle of the crimper.

Next, apply outward and downward pressure to the handles to start folding down the top rib. Continue the outward and downward pressure until the panel rib is flat.

**NOTE:**

**DO NOT** use this crimper to temporarily hand crimp any part of the panel seam.

### Small QuadLok Hand Crimper



Shown is the TS-324 Panel for example only

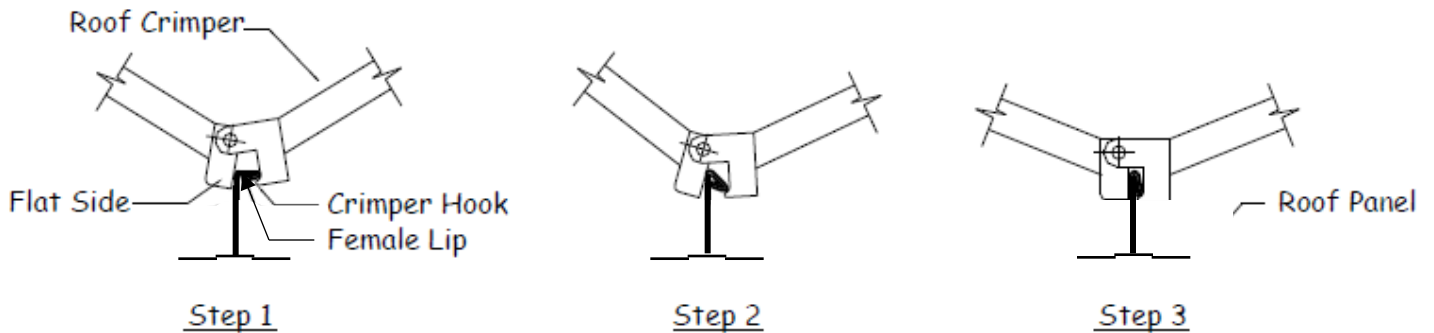

## Panel Craft Roof System Seaming Guide

### 15.0 MANUAL CRIMPING TOOL OPERATION FOR THE QUADLOK ( STAND-UP CRIMPER)

#### 15.1 Stand-up Hand Crimping Tool Nomenclature

The detail below identifies the operational parts of the stand-up crimping tool.

#### 15.2 Assemble the Stand-up Crimping Tool

When received, the crimping tool may be partially disassembled. Assemble the handle to the push rod with the provided lock pins.

#### 15.3 Tool Orientation to the Seam

Orient the tool to fit correctly onto the roof panel seam as shown in Step 1 below. The stationary handle **MUST** be in the vertical position and the operating handle **MUST** be rotated up to the open position.

### 15.4 Forming the Seam

The tool is correctly positioned on the panel seam, when the operating handle is UP and the stationary shoe is DOWN against the top of the seam.

While holding the stationary handle vertical, rotate the operating handle down to the position as shown in Step 2. This will form the seam into a single QuadLok shaped crimp profile.

#### NOTE:

This hand crimper is meant to be used continuously and by doing so, will form a finished QuadLok seam. This crimper is for hand crimping small edges, corner zones, and for locating the QuadLok seamer onto the seam.

#### CAUTION:

The crimper or seam could be damaged, if the stationary shoe is **NOT COMPLETELY** down on the seam.

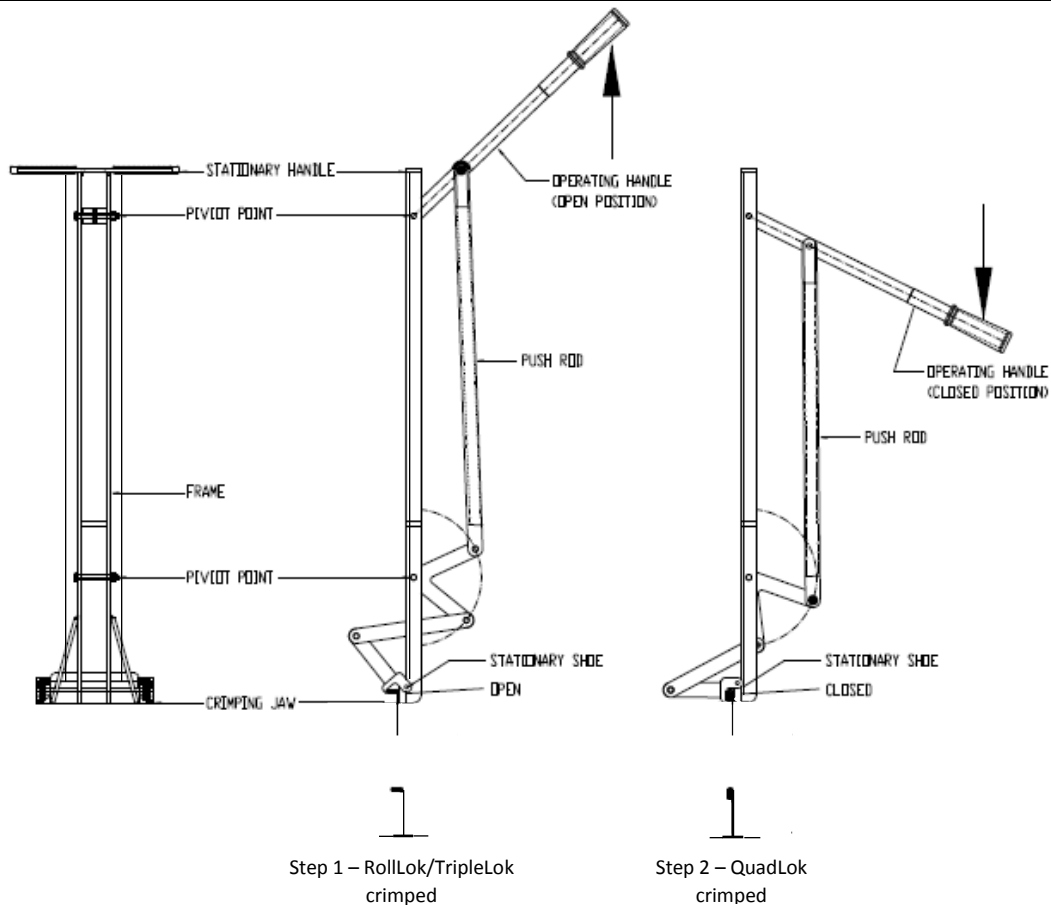

#### NOTE:

**Do not** use this crimper to temporarily hand crimp any part of the panel seam.

## Panel Craft Roof System Seaming Guide

<p><b>16.0 QUADLOK SEAMING DETAILS (SINGLE PASS OPERATION)</b></p> <p><b>16.1 Locking Seamer on Panel</b>          Prior to running a single directional QuadLok seamer, you <b>MUST</b> hand crimp or electrically seam the entire roof into a finished RollLok/TripleLok seam profile. To start the QuadLok seamer, you need to hand crimp a small area with a QuadLok hand crimper (as shown below). After the QuadLok hand crimping has been completed, place the QuadLok seamer on the panel rib, aligning the number four station roller over the previously QuadLok hand crimped area. (<b>NOTE: Make sure the arrow on the seamer is pointing in the direction you are seaming</b>). Next lock down the first station handle, followed by the fourth station handle.</p>	<p>Finish by locking down handles 2 &amp; 3. Make sure that the number one station has engaged the panel (as shown below).</p> <p><b>16.2 Motor Seaming</b>          Once the seamer is properly locked on the pre-crimped seam, switch the machine on and seam the full length of each roof panel.</p> <p>The seamer will run from eave to ridge OR ridge to eave, depending on the way the roof panels were installed.</p> <p><b>NOTE:</b>          It is recommended <b>NOT</b> to run the seamer over the panel end laps. The end laps should be hand crimped for a proper finished seam.</p>
--	---

Single Directional QuadLok Seamer

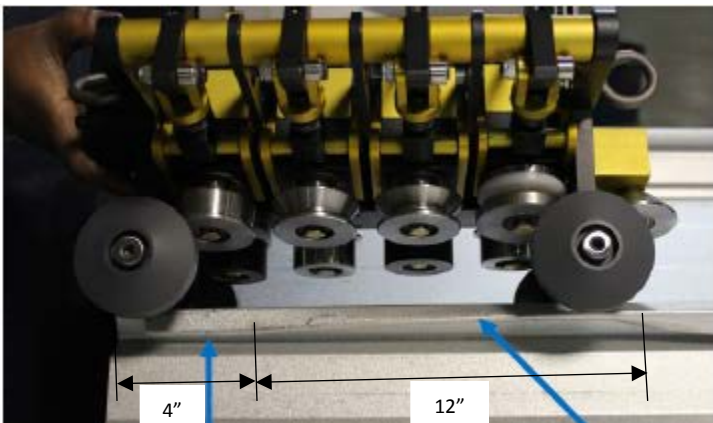

Hand Crimped QuadLok Seam

Hand Crimper RollLok/TripleLok Seam

Make sure this roller is engaging the panel as shown.

# Panel Craft Roof System Seaming Guide

## 17.0 QUADLOK SEAMING DETAILS (DOUBLE PASS OPERATION)

### 17.1 Prior to Seaming

Prior to QuadLok seaming, the roof panels **MUST** have been fully TripleLok seamed. This is accomplished with the Primary motorized three or four station seaming machine. **In order to achieve a good QuadLok seam, you MUST first have a good TripleLok seam.** Inspect ALL TripleLok seams PRIOR to running the QuadLok seamer. Questionable TripleLok seams should be re-crimped with the hand crimper or motorized seamed again with the "Primary Seamer" (TripleLok).

### 17.2 Locking Seamer on Panel

Prior to running a single directional QuadLok seamer, you **MUST** hand crimp a small area with a QuadLok hand crimper as described in Section 16.0. After the QuadLok hand crimping had been completed, place the QuadLok seamer on the panel rib, aligning the number four station roller over the previously QuadLok hand crimped area. (**NOTE: Make sure the arrow on the seamer is pointing in the direction you are seaming**).

Next lock down the first station handle, followed by the fourth station handle.

Finish by locking down handles 2 & 3. Make sure that the number one station has engaged the panel (as shown below in Figure 34).

### 17.3 Motor Seaming

Once the seamer is properly locked on the pre-crimped seam, switch the machine on and seam the full length of each roof panel.

The seamer will run from eave to ridge OR ridge to eave, depending on the way the roof panels were installed.

### NOTE:

It is recommended **NOT** to run the seamer over the panel end laps. The end laps should be hand crimped for a proper finished seam.

### 17.4 Finished Seam Detail

Check that the finished seam is correctly formed as shown in the detail below.



Figure 34



Finished QuadLok Seam

Four Station QuadLok  
Seamer  
(Double Pass Operation)





# Panel Craft Roof System Seaming Guide

## 18.0 MOTORIZED SEAMING MACHINE MAINTENANCE

### 18.1 General

The motorized seaming machine is a precision fabricated, high performance, portable roll-forming machine. This relatively lightweight machine does the tough job of forming the extra strong TripleLok and QuadLok seams under often rugged field conditions.

Although designed for tough industrial use, the seaming machine requires proper maintenance to assure proper seaming and efficient, trouble-free operation.

**CAUTION: Failure to properly maintain the seaming machine, as instructed below, can result in faulty or damaged seams and costly breakdown of the seaming machine.**

### 18.2 Seaming Rolls

The seaming rolls require the following regular maintenance:

- Assure that the seaming machine's rolls are clear of dirt, grease, sealant, and Galvalume/paint build-up, etc. Rollers may be cleaned with mineral spirits. Please follow manufacturer's instructions when using mineral spirits. Make sure rollers are clear of mastic and dry before seaming.
- Assure that the seaming machine's rolls are tight on their shafts. Check and tighten the rolls retainer screws as necessary.

### 18.3 Cooling Vents

To prevent motor overheating, the motor has vents and an internal fan to provide a cooling airflow over the internal motor ports.

The cooling vents are located at the front and rear of the motor. At the front of the motor, the vents are the slots between the motor housing and gear box. The rear vents are on the end of the motor housing. Check frequently to assure that these vents are kept clean and clear of debris and string sealant, etc.

While the machine is running, never cover the machine or place it in a position where the cooling airflow to the vents will be restricted.

## Panel Craft Roof System Seaming Guide

### 19.0 SEAMER TROUBLESHOOTING GUIDE

The chart below is a list of possible problems and solutions. ***If you cannot resolve the problem with this chart, STOP work immediately and contact either Horizon Structural Systems Customer Service or a representative from the seamer supplier.***

Seaming Problem	Possible Cause	Look For	Recommended Fix
Seaming machine drags, stalls at clips, runs intermittently, or won't run at all.	Extension cord too long and/or not heavy enough gauge.	7+ amps at the motor with no load (locking handle locked).  10+ amps at the motor during seaming (between clips).	Use a shorter and heavier gauge extension cord.
	Generator is not supplying the proper amps to the seamer.	7+ amps at the motor with no load (locking handle locked).  10+ amps at the motor during seaming (between clips).	Use a larger generator.
	Faulty motor.	7+ amps at the motor with no load (locking handle locked).  10+ amps at the motor during seaming (between clips).	Notify HSS or the seamer supplier for a replacement unit.
	Seam is NOT crimped.	Un-crimped areas.	Complete a RollLok seam
Seam hook is not closed or improper nesting of the male to female and/or clip.	Excess panel coverage width. MUST be held 24-inches O.C.	Cladding or paint deposits on forming rollers.	Ensure correct panel coverage width at installation.
	Incorrect profile or damaged (deformed) clip or male/female panel leg.	Seam does not appear to be fully engaged.	Correct the profile of the male/female panel leg. If necessary, hand crimp the corrected area.
Creasing, scuffing, etched line along atop of seam, and/or deformation of seam.	Cam roller does not turn freely.	Cam roller bearing frozen, or fouled by sealant or debris.	Clean and lubricate or replace the cam roller.
Cladding/paint pick-off.	Incorrect profile or damaged (deformed) clip or male/female panel leg.	Seam does not appear to be fully engaged.	Correct the profile of the clip or male/female panel leg. Hand crimp the corrected area.
	Excess panel coverage width.	Cladding or paint deposits on forming rollers.	Ensure correct panel coverage width during installation.