

# TS-324

## Roof System Installation Guide

Horizon Structural Systems Inc.

3950 Hwy 46 West #200,  
New Braunfels, TX 78132

830-629-8000

<https://horizonstructural.com>

[info@horizonstructural.com](mailto:info@horizonstructural.com)



DUE TO THE PROCESS OF CONTINUOUS IMPROVEMENT, THE  
PRODUCTS AND PROCEDURES IN THIS MANUAL ARE SUBJECT TO  
CHANGE WITHOUT NOTICE

MANUAL REVISION INFORMATION			
ACTIVITY	ADDENDUM RELEASE #	PAGES REVISED	RELEASE DATE
Revised	#1	All	08/31/2018

NOTES:

# TABLE OF CONTENTS

<b>1.0</b>	<b>General</b> .....	7
1.1	Purpose of the manual.....	7
1.2	Buyer’s responsibility.....	7
1.3	MBMA.....	7
1.4	Disclaimer.....	7
1.5	Unloading and storing.....	8
1.6	Erection sequence.....	8
1.7	Coordination with other trades.....	8
1.8	Erection care.....	8
1.9	Field cutting of panels.....	9
1.10	Trim and Flashing.....	9
1.11	Engineering and Reinforcing Materials.....	9
<b>2.0</b>	<b>Design and Performance Criteria</b> .....	10
2.1	Roof system.....	10
2.2	Panel clip spacing.....	10
2.3	Panel clip fastener requirements.....	10
2.4	Roof top units and curb supports.....	10
2.5	Insulation requirements.....	10
<b>3.0</b>	<b>Composite TS-324™ Roof System</b> .....	11
3.1	Product definition.....	11
3.2	Vapor barrier.....	11
3.3	Insulation.....	11
<b>4.0</b>	<b>Horizon TS-324™ Roof Components with Engineering</b> .....	11
4.1	Components with engineering definition.....	11
4.2	Diaphragm.....	11
4.3	Clip fastening requirements.....	11
<b>5.0</b>	<b>Receiving &amp; Handling Roof Materials</b> .....	12
5.1	Field storage of materials.....	12
5.2	Handling individual roof panels.....	14
5.3	Handling roof materials in strong winds.....	14
5.4	Material inventory.....	15
5.5	Equipment for unloading and lifting.....	15
5.6	Lifting roof panel bundles.....	16
5.7	Placing panel bundles on the roof.....	19
<b>6.0</b>	<b>Safe Roof Installation</b> .....	20
6.1	Regulations.....	20
6.2	Erector’s responsibility.....	20
6.3	Walking and working on roof panels.....	20
6.4	Safety equipment.....	21
6.5	Crew size.....	21
6.6	Panel overhang.....	21

6.7	Point loads.....	21
6.8	Slick surfaces.....	21
6.9	Electrical conductance.....	21
6.10	False security of insulation.....	21
6.11	Sharp edges.....	21
6.12	Safe roof installation summary.....	21
<b>7.0</b>	<b>Checking the Structure.....</b>	<b>22</b>
7.1	Completed and braced.....	22
7.2	Lateral stability.....	22
7.3	Alignment.....	22
7.4	Toerances.....	22
7.5	Measuring.....	22
7.6	Aesthetic acceptance.....	22
7.7	Corrections.....	22
<b>8.0</b>	<b>Installation Basics.....</b>	<b>23</b>
8.1	Proper tools.....	23
8.2	Mastic.....	23
8.3	Fasteners.....	24
8.4	Field cutting of panels and flashing.....	26
8.5	Sheeting direction and modularity.....	27
8.6	Layout and checking coverage.....	27
8.7	Appearance consideration.....	27
8.8	Inspection of the roof assembly during installation.....	27
8.9	Inspection list.....	27
8.10	Roof leak troubleshooting & potential causes of roof leaks.....	31
<b>9.0</b>	<b>Standard Hardware Parts.....</b>	<b>32</b>
9.1	General.....	32
9.2	Standard parts.....	33
9.3	TS-324 roof accessory tools.....	40
<b>10.0</b>	<b>Preparation for Roof Panel Installation.....</b>	<b>41</b>
10.1	General.....	41
10.2	Orientation and explanation.....	41
10.3	Wall rake angle attachment.....	42
10.4	Eave plate attachment.....	43
10.5	Rake support angle installation.....	44
10.6	Eave trim installation.....	46
10.7	Starter run of insulation installation .....	47
10.8	Thermal blocks.....	49
10.9	EPS foam spacers.....	49
10.10	Proper mastic installation procedures.....	50
10.11	Eave sealant installation.....	51
<b>11.0</b>	<b>Eave Start Panel Installation.....</b>	<b>52</b>
11.1	Panel section, description and nomenclature.....	52
11.2	Orientation view.....	53
11.3	Installing the low eave void closure.....	54
11.4	Installing the eave start panel.....	55

11.5	Installing the leading edge panel clips.....	56
11.6	Typical panel clip attachment details.....	57
11.7	Installation of the backup plate.....	59
<b>12.0</b>	<b>Intermediate Start Panel Installation.....</b>	<b>61</b>
12.1	Installation of the intermediate start panel mastic.....	61
12.2	Installation of the Intermediate Start Panel Butyl Caulk .....	62
12.3	Alignment of the intermediate start panel.....	63
12.4	Fastening of the intermediate start panel.....	64
<b>13.0</b>	<b>Full Panel Run Installation.....</b>	<b>67</b>
13.1	Eave, End Lap and Ridge/High Eave Pigtail Mastic Installation.....	67
13.2	Panel side lap assembly.....	70
13.3	Installing the first full panel run, starting at the low eave.....	71
13.4	Panel width modularity.....	72
13.5	Adjusting panel width modularity.....	74
13.6	The use of an end lap clamp.....	76
13.7	Installing the next panel run end lap.....	77
13.8	Termination panel installation.....	78
13.9	Termination panel installation (on module).....	79
13.10	Termination panel installation (off module).....	80
13.11	Outside closure installation preparation.....	82
13.12	Outside closure installation (notching of panel).....	83
13.13	Outside closure installation (installing the backup pate).....	84
13.14	Outside closure installation (applying the tape mastics).....	85
13.15	Outside closure installation.....	87
13.16	Outside closure installation at a modification of a termination panel.....	90
13.17	Hand crimping/motorized panel seaming.....	92
<b>14.0</b>	<b>Preparation for Roof Line Trim Installation.....</b>	<b>93</b>
14.1	Preparation for trim installation.....	94
<b>15.0</b>	<b>Standard Roof Line Trim Parts.....</b>	<b>95</b>
15.1	General and trim parts.....	95
<b>16.0</b>	<b>Roof Line Trim Installation.....</b>	<b>98</b>
16.1	Standard rake trim installation (on module).....	98
16.2	Standard rake trim installation (off module).....	99
16.3	Standard rake trim installation .....	100
16.4	Standard slide trim installation.....	101
16.5	Standard peak box installation.....	102
16.6	Standard ridge cap installation.....	104
16.7	Standard ridge cap tape mastic installation.....	105
16.8	Standard ridge cap and end cap installation.....	106
16.9	Standard ridge cap lap installation.....	108
16.10	Standard rake trim end cap installation.....	109
16.11	Standard rake parapet transition flashing installation.....	110
16.12	Standard rake parapet transition flashing installation details.....	113
16.13	Standard rake parapet transition flashing lap installation.....	115
16.14	Standard rake parapet transition flashing and ridge cap installation.....	117
16.15	Standard rake parapet transition flashing to high eave trim installation (inside corner).....	120

16.16	Standard rake parapet transition flashing to high eave trim installation (outside corner).....	122
16.17	Lean-To to High Eave Rake Box Installation.....	123
16.18	High eave parapet trim lap.....	125
16.19	Eave gutter installation preparation.....	126
16.20	Eave gutter end lap/end cap installation.....	128
16.21	Eave gutter installation.....	129
16.22	Eave gutter/rake trim installation.....	130
<b>17.0</b>	<b>TS-324 Check list</b> .....	<b>131</b>
17.1	TS-324 roof detail compliance list.....	131

## 1.0 General

### 1.1 Purpose of this manual

This erection manual is provided to Horizon Builders and their erectors as the recommended procedure for the correct assembly of the Horizon Building Systems TS-324™ Standing Seam Roof System.

This manual is intended to be used in conjunction with the project's erection drawings to help plan and organize the installation of the Horizon TS-324™ Standing Seam Roof System. The erection drawings identify the applicable roof conditions and govern specific part arrangements. The instructions will help you identify parts, establish the installation sequence, demonstrate correct assembly, and point out any areas or procedures requiring special emphasis or attention.

This installation manual applies to the standard conditions. Custom roof conditions, including custom details and instructions, will be covered by the erection drawings. **In the case of conflict between this installation manual and the erection drawings, the erection drawings will take precedence.**

The Horizon TS-324™ Roof System can be erected on many different types of construction. However, for this manual we have assumed this roof system will be erected on a pre-engineered metal building.

A TS-324 check list is provided at the end of this manual for punching out the roof system. Please review this list prior to erecting the roof.

### 1.2 Buyer's Responsibility

The buyer is responsible for proper installation of the roof in accordance with the erection drawings and this manual, and in accordance with good engineering and construction practices.

The buyer must take the responsibility for selecting a competent erector, insist that the work be performed by qualified and experienced standing seam metal roof installers, and insist that the erector take time to study and understand this manual, then assure that the erector correctly follows the manual's instructions.

Horizon does not guarantee and is not liable for the quality of the erection. SBS is not responsible for building defects that may be attributed to improper erection or negligence of other parties.

Clarification concerning the SBS TS-324 roof installation should be directed to the Horizon Building Systems Customer Service Department. The following is a list of addresses and phone numbers for the customer service representative at each division:

**3950 Hwy 46 West #200, New Braunfels, TX 78132**

**830-629-8000**

**info@horizonstructural.com**

### 1.3 MBMA

This building is designed, manufactured and delivered in accordance with the 2006 M.B.M.A. (Metal Building Manufacturer's Association) metal building systems manual. Consult the information in the "Common Industry Practices" section for more information.

### 1.4 Disclaimer

**THE PRODUCTS AND PROCEDURES IN THIS MANUAL ARE SUBJECT TO CHANGE WITHOUT NOTICE.**

### 1.5 Unloading and Storage

Check the quantities and condition of **all** TS-324 bundles and trim crates on arrival. Note on the delivery tickets any shortages, damage, or discrepancies. SBS shall **not be** liable for damage or shortages that are not noted on the delivery tickets. The customer assumes full responsibility for the condition of this material after deliver by the trucking company.

Extreme care should be exercised when unloading and handling the panel bundles and accessory crates to prevent damage. The weight of the panel bundle is printed on the bundle tag on the end of each bundle. If the tag is not on the bundle, you may calculate the weight of the bundle with the formula: (Qty. of panels x Bundle length x 2.5 pounds per foot).

Bundles up to 25-feet long can be lifted with a forklift. Bundles over 25-feet long shall be lifted with a crane utilizing a spreader bar with 4-inch minimum width nylon straps. Straps should be 15 to 20-feet apart. To avoid damage to the panels, steel cables, chains, or chokers shall not be used.

The SBS panels and accessories shall be stored on high ground, sloped to drain and tarped to protect from moisture formation. The tarp should be open at each end to allow consistent airflow through the bundles. The recommended procedures are outlined in this manual. SBS will not be held responsible for damage or discoloration of panels caused by improper storage.

### 1.6 Erection Sequence

The Horizon TS-324™ Roof System is designed to be erected from either end of the building. In rare cases, due to the building layout, it may be required to start erection from a specific end. In those cases, this will be noted as such on the roof sheeting plan.

Because the roof can be started from either end, the panel ribs may not be in alignment across the ridge. This is normal practice for the Horizon TS-324™ Roof System.

The erector of the Horizon TS-324™ Roof System shall exercise great care and attention to the details as shown on the erection drawings and in the Horizon TS-324™ erection manual to insure a secure and proper fit of all components. SBS shall not be responsible for supervising and/or coordinating the erection of the TS-324 roof system with other trades.

Due consideration must be given by the erector to the effects of thermal expansion and contraction when erecting a roof tie-in to an existing structure to insure a safe, secure, weather tight condition. Flashing for tie-ins to existing buildings is typically not included as part of the material provided by SBS. Refer to the sections and details for specific materials provided by SBS and does not affect the performance of the roof system.

For buildings with roof translucent panels, in order to align the translucent panels across the ridge, it is suggested to erect the roof panels on both sides of the ridge from the same end of the building, utilizing the same start panel width. Panel runs with translucent panels have been placed as specified in the order documents.

### 1.7 Coordination with Other Trades

Supports for the Horizon TS-324™ Roof System shall be provided and are required as shown in the sections and as noted in these specifications. All necessary clearance dimensions for proper elevations relative to the roof panels have been shown. The contractor shall be responsible for coordinating these dimensional requirements with other trades associated with the building roof system.

### 1.8 Erection Care

The erector must be skilled in the erection of Metal Building Systems, including roof panels, and is responsible for complying with all applicable local, federal and state construction and safety regulations including OSHA regulations as well as any applicable requirements of local, national, or international union rules or practices.

The erector remains solely responsible for the safety and appropriateness of all techniques and methods utilized by its crew in the erection of the Metal Building System and/or the Horizon TS-324™ Roof System.

The erector and/or contractor is also responsible for supplying safety devices, such as scaffolds, runways, nets, etc. which may be required to safely erect the Metal Building System and/or TS-324 roof system.



### **1.9 Field Cutting of Panels**

When field cutting or mitering metal panels, non-abrasive cutting tools such as nibblers or tin-snips shall be used. Abrasive cutting tools such as mechanical grinders or power-saws, can damage the Galvalume finish and create excess metal shavings that can corrode the panels. The use of non-approved cutting devices may void the factory warranty.

### **1.10 Trim and Flashing**

NOTE: Trim and/or flashing for transitions to existing buildings is not supplied by SBS.

### **1.11 Engineering and reinforcing Materials.**

Note: SBS does not supply engineering investigations or materials to reinforce existing non-Horizon buildings. These type investigations must be submitted to the project engineer of record.

## 2.0 Design and Performance Criteria

### 2.1 Roof System

The SBS TS-324 Roof System consists of 24 gage panels with a nominal coverage of 2'-0" and a panel seam that is 3" tall. The flat of the panel will be elevated above the top of the roof secondary member by either 3/8" (if short clips are used) or 1-3/8" (if tall clips are used). Refer to the details and sections on the erection drawings for specific panel clip type.

The Horizon TS-324™ Roof System has three seam type options. The project design and performance requirements govern which seam type is required.

Different seam types may be used on specific areas of a roof. In all cases, refer to the erection drawing roof sheeting plan and details for seam type and location. Also refer to the Seaming Manual for instructions on proper use of the seaming equipment.

### 2.2 Panel Clip Spacing

The Horizon TS-324™ Roof System uses a clip to attach the panels to the roof secondary members. Panel clip spacing is as follows:

#### For TS-324 Roof on a Horizon Building:

Clips are required at every purlin and/or joist. Also at every sub-purlin and/or sub-joist. Never attach clip to strut purlins.

#### For TS-324 Roof on a non-Horizon Building:

Maximum clip spacing is to be 5'-0" for purlin roofs, and 5"-6" maximum for joist roof.

### 2.3 Panel Clip Fastener Requirements

SBS standard clip fasteners are designed to fasten to a steel structural member of .060" minimum thickness (16 gage). A minimum of two fasteners are required to engage to the structural member at every panel clip location. In certain instances, three fasteners may be required per clip. See the final set of erection drawings for your specific clip fastener requirements.

Spread the clip fasteners as far apart as possible. Avoid placing fasteners side by side.

Check fasteners to see if they are securely engaged into the roof secondary member.

**Do not over-drive screws!** Over-driving can strip the threads and/or damage the sealing washer. Use screw gun with torque control set to function properly for the combination of fastener size, hole size, and material thickness.

**DO NOT USE AN IMPACT DRIVER.**

Required fastener pullout values are dependent upon project location, size, building code, and loading. Consult Horizon Engineering for project dependent fastener specifications.

### 2.4 Roof Top Units and Curb Supports

The Horizon TS-324™ Roof System and the roof curbs are elevated above the top of the roof secondary structural members. Roof curb sub-framing is level with the secondary members. If your building has roof curbs, please refer to the respective roof curb erection manual for more information.

The SBS Roof System is designed as a floating system. Curb framing and flashing must be designed accordingly to allow the curb system to float with the TS-324 roof during thermal movement. Roof curbs shall not span the ridge of a building.

### 2.5 Insulation Requirements

SBS recommends that insulation be used in all TS-324 roof applications to avoid problems with condensation forming on the underside of the sheeting. This also provides a buffer between the purlins and the TS-324 roof to eliminate noise and possible damage due to metal to metal contact. SBS can supply a noise reducing foam tape for use in limited applications (canopies, etc.) when included as part of the roof order. Refer to the details for foam tape requirements.

### **3.0 Composite Horizon TS-324™ Roof System**

(Application for Composite Horizon TS-324 Roof Systems)

#### **3.1 Product Definition**

Refer to the sections and details on the erection drawings for specific clip fastening requirements, insulation thickness requirements, and liner deck type.

SBS recommends the roof secondary members be pre-drilled with 3/16" diameter holes to accept the panel clip fasteners to avoid potential fastener breakage.

Composite TS-324 roof without the use of a liner deck is not a SBS standard product application. Due consideration must be given by the engineer of record or architect when this occurs to the effects of condensation. In addition, great care must be taken by the erector to insure that the roof system is erected in a safe, quality manner.

#### **3.2 Vapor Barrier**

Vapor barrier/vapor retarder must be used between the liner decking and the rigid board insulation to prevent condensation. Refer to the erection drawing details.

#### **3.3 Insulation**

Rigid board insulation is used in conjunction with a Composite Horizon TS-324™ Roof System. The rigid board insulation must be cut to allow free movement of the back-up plates at panel splices, rake and ridge locations.

### **4.0 Horizon TS-324™ Roof Components with Engineering**

#### **4.1 Components with Engineering Definition**

In a case where SBS is providing the TS-324 Roof System to be used in conjunction with a non-Horizon structure, SBS refers to that as a "Components with Engineering". This simply means that SBS shall calculate the quantities and lengths for the material required. SBS is performing no engineering study of the existing structure. The engineer of record on the project shall be responsible for coordinating the Horizon TS-324™ Roof System with the other trades of the project to insure a safe, quality, and proper application of the roof system. SBS does not supply clip fasteners to attach to non-Horizon framing materials.

#### **4.2 Diaphragm**

The Horizon TS-324™ roof is designed to accommodate thermal expansion and contraction and will NOT act as a diaphragm for resisting lateral load forces or providing lateral stability to the roof structural members. Due consideration for this must be addressed by the project engineer of record. In addition, the TS-324 roof, because it is designed to float, will not support structural member laterally. When replacing an existing screw down roof, additional bracing may be required to laterally support the members. Engineering and material for these uses shall not be provided by SBS.

#### **4.3 Clip Fastening Requirements**

Refer to Section 2.3 – "Design and Performance Criteria" for TS-324 roof panel clip fastening requirements.

## 5.0 Receiving & Handling Roof Materials

### 5.1 Field Storage of Materials

Upon acceptance of the shipment, the buyer or his representative is responsible for proper handling, storage, and security of the roof materials. SBS is not liable for damage, injury, or loss as a result of improper storage and/or handling.

The roof panel bundles should be stored on the job site in accordance with the following recommendations.

- a. Store panels in a protected area, out of standing water and drifting snow, etc. Panel bundles and trim crates should be blocked 12-inches above grade.
- b. Elevate panels with blocking to allow air circulation under the bundle to occur.
- c. Slope panels for drainage of moisture from the panels.
- d. As necessary, cover panels with waterproof tarp, allowing for air circulation (do not wrap tarp under panel bundle or restrict air movement).
- e. Inspect panes daily for moisture accumulation.
- f. If panel bundles contain moisture, the panels should be dried and re-stacked. Use care in re-stacking to avoid damage to panels.
- g. Opened or re-stacked panel bundles should be secured to prevent wind damage.
- h. Bundles should be located over primary structural frame lines, not in the middle of the bay. Blocking should be used between the purlins/joists at the panel bundle locations. This blocking is not supplied by SBS.

When moving panel bundles, extreme caution should be taken to prevent damage to the panel edges. Uncrated panels should be supported at each end and at 8' (maximum) spaces.

All bundles or loose panels on the roof should be secured to the roof secondary members at the end of each workday. On steep sloped roofs, provisions should be taken to prevent panels, panel bundles, and/or trim crates from sliding off of the roof. Be sure to set panel bundles on the roof in the proper direction for the installation sequence.

Trim and accessories should be stored in a secure area and protected from damage, weather, and theft. Fasteners, mastics, closures, etc. should be stored out of the weather and protected from contamination.

**IMPORTANT NOTE:** The finish on these panels may not perform as intended if not erected within 90 days from receipt at the job site. The finish is also subject to severe damage if moisture, debris, or dust is allowed to get between the panels; therefore, panels **MUST BE STORED UNDER COVER** with one end elevated to allow for drainage and protection against moisture, dust, or debris until erected. The manufacturer will not accept claims for non-performing panels if not properly stored at the job site. The customer assumes full responsibility for the condition of this material after deliver by the trucking company.

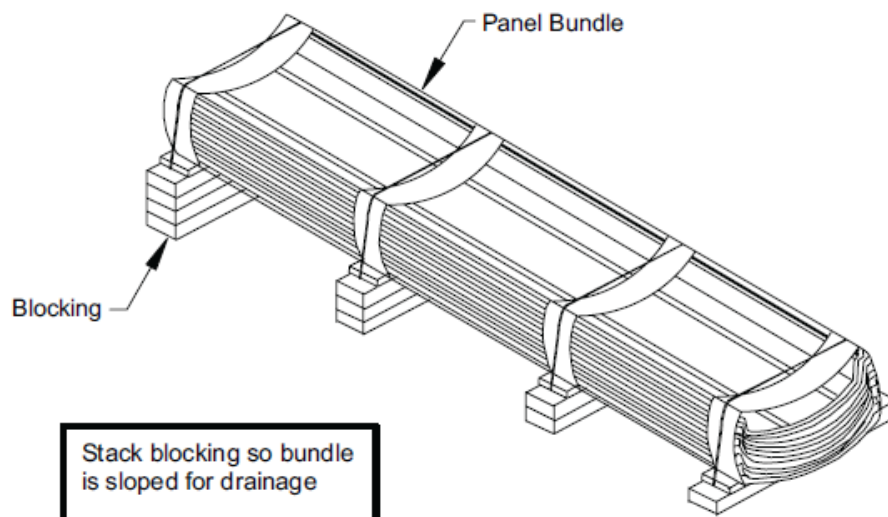

### 5.1 Field Storage of Materials

As necessary, cover panels with waterproof tarp, allowing for air circulation (do not wrap tarp under panel bundle or restrict air movement).

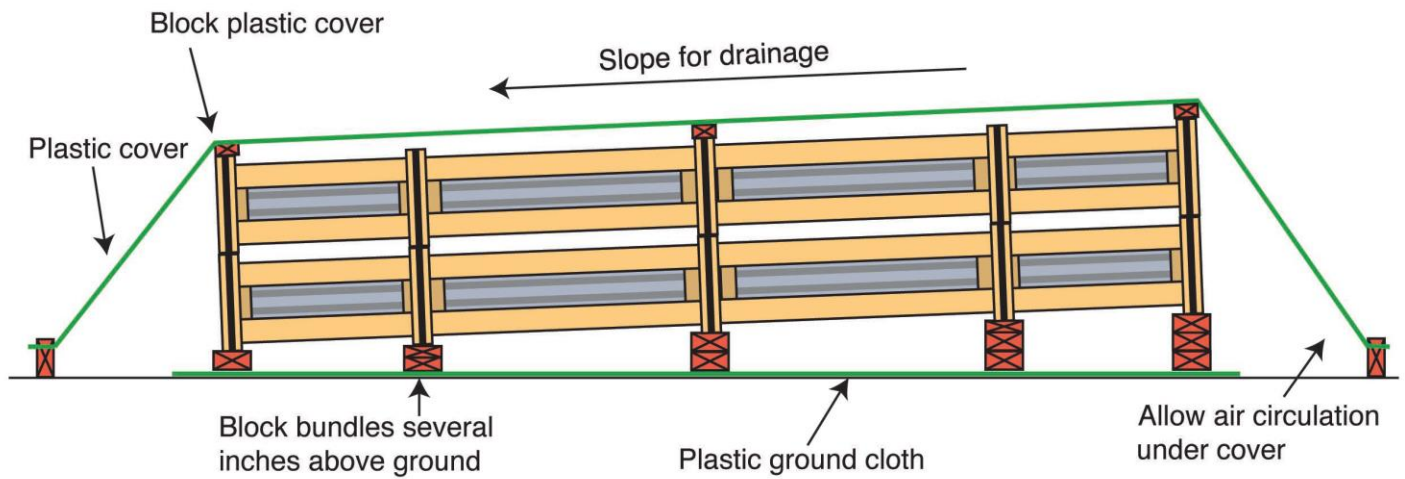
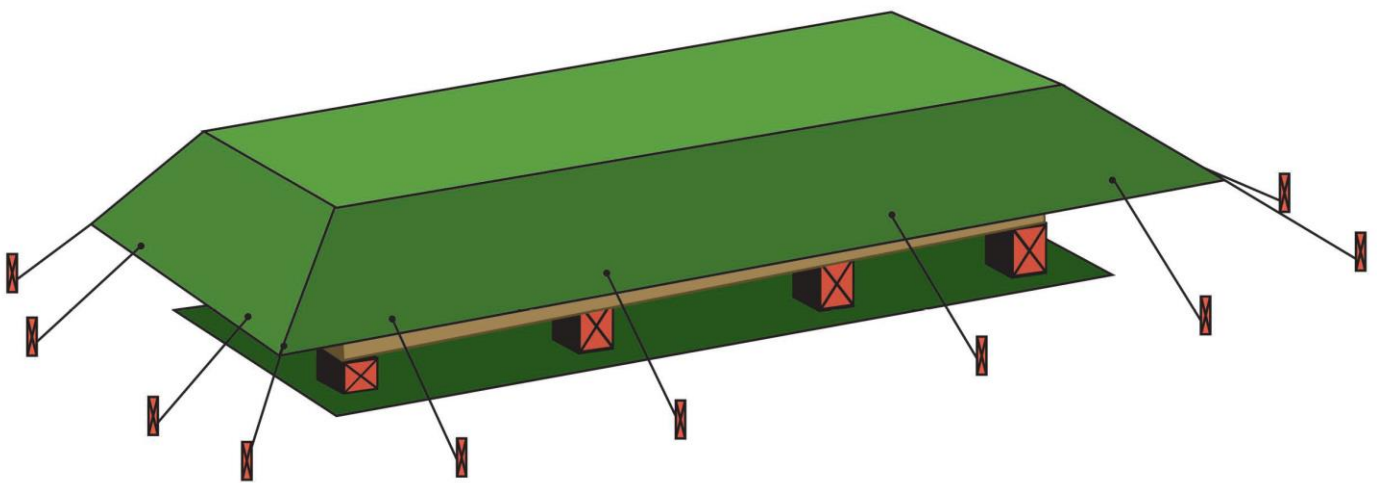

Illustration of Proper storage and tarp covering.



### 5.2 Handling Individual Roof Panels

To lift individual panels, lift one side of the panel by the seam, letting it hang naturally to prevent buckling. Pick-up points should not be more than 10' apart. Do not pick-up panels by the ends only, or in a flat position. Do not use any type of steel or cable slings.

If the individual panels are to be lifted to the roof by hand line, the common method is to use the vice grip "C" clamps. Position the clamps on the flat of the panel as close as possible to one edge so the panel is lifted in a vertical position. The jaws of the vice grips must be padded to prevent damage to the panel surface. The clamps should be uniformly spaced, no more than 10' apart and the hand lines must be pulled in unison so that uneven lifting does not buckle the panel. Be sure the clamps are tight on the panel and the hand line is secure to prevent dropping the panel, which can result in personal injury and property damage.

### 5.3 Handling Roof Materials in Strong Winds

Do not attempt to move panels in strong winds. Wind pressure can easily cause a person to lose balance and fall. Strong wind uplift on a panel can lift the weight of the person carrying the panel.

Loose, wind borne panels are very dangerous and can cause severe injury and damage.

Secure stacks of panels with banding or tie-downs, so wind will not blow the panels off the roof. Clamp individual unsecured panels to the roof secondary members. Clamp or block panel bundles and trim crates to prevent them from sliding down the roof slope.

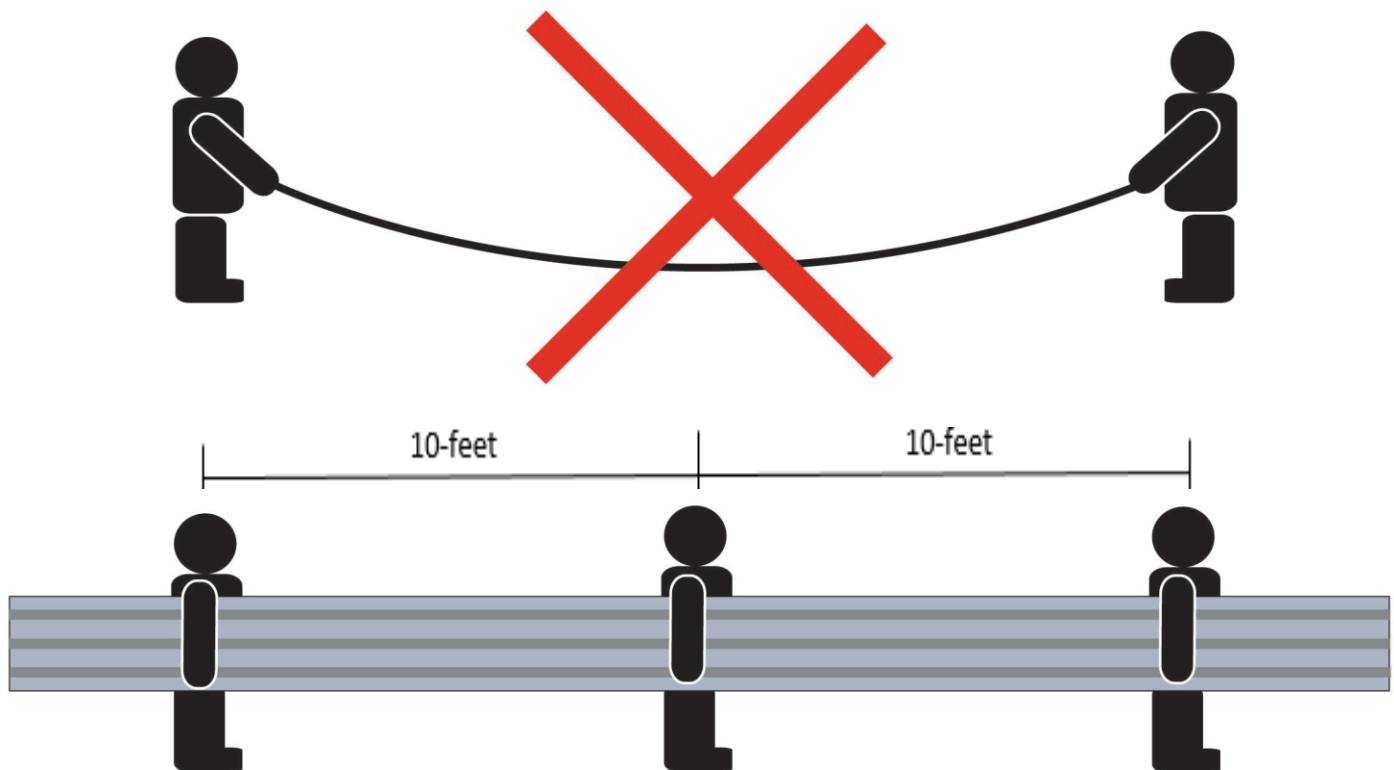

#### 5.4 Material Inventory

Your material is carefully inspected and packaged before leaving the plant and accepted by the transportation company as being complete and in satisfactory condition. It is the carrier's responsibility to deliver the shipment intact. Note any damage or discrepancies on the delivery tickets before signing as receiver.

Conducting a material inventory at the time of delivery is essential. By conducting the materials inventory, the erector is able to identify any material shortage or damage and avoid stopping installation later because of such shortage or damage. All claims must be filed with SBS Customer Service Representatives **prior** to any field modifications or purchases that may result in a charge to SBS.

It is imperative that any shortages or damages of the delivered materials be noted at once and clearly marked on the bill of lading before signature of acceptance. Notify SBS immediately of any conflicts. SBS will not be responsible for shortages or damages unless they are noted on the bill of lading. SBS is not responsible for items accepted in questionable condition.

In the case of packaged components (such as clips, fasteners, and mastics, etc.), the quantities are marked on their container and should be checked against the bill of materials.

#### 5.5 Equipment for Unloading and Lifting

Hoisting equipment is necessary to unload and position the panels and accessory crates for site storage and installation. The equipment must have sufficient capacity and reach to place the material where it is required for efficient installation.

Nylon slings will be required to minimize panel damage. Horizon recommends a minimum 4" wide nylon sling be used. SBS panels are rolled and banded. No exterior cover sheets are used, so care must be taken to prevent damage.

A spreader bar will be required for the longer panel bundles to assure correct sling spacing and uniform lifting. The spreader bar must be large enough to handle the maximum panel bundle weight and length.

Trim crates are to be handled in the same manner as panel bundles.

Panel bundle weights can be found on the I.D. tag. Maximum weight is 4000 pounds. Steel chokers, cables or chains shall not be used.

**NOTE:** Panels and trim with strippable film will require that UV exposure and minimizing exposure to high heat and moisture be avoided so the masking can be easily removed after installation. Strippable film **MUST** be removed immediately after installation or it may become difficult or impossible to remove.

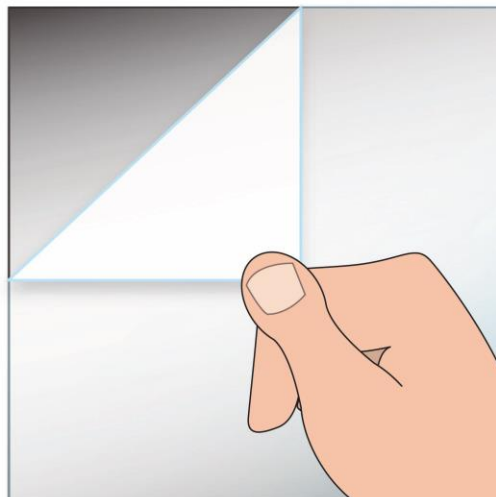

### 5.6 Lifting Roof Panel Bundles

Bundles over 25-feet long should be handled with a crane using a spreader bar and nylon slings. Lifting should occur at center of gravity. Locate slings at  $\frac{1}{4}$  points of the length of the panel bundle from each end of the bundle.

Loads should always be checked for secure hook-up, proper balance, and lift clearance. Tag lines should be used if to control the load during lifting, especially if operating in the wind.

Panel crates less than 25' long may be lifted with a forklift only if the forks are spread at least 5' apart and blocking is used to prevent panel damage by the forks.

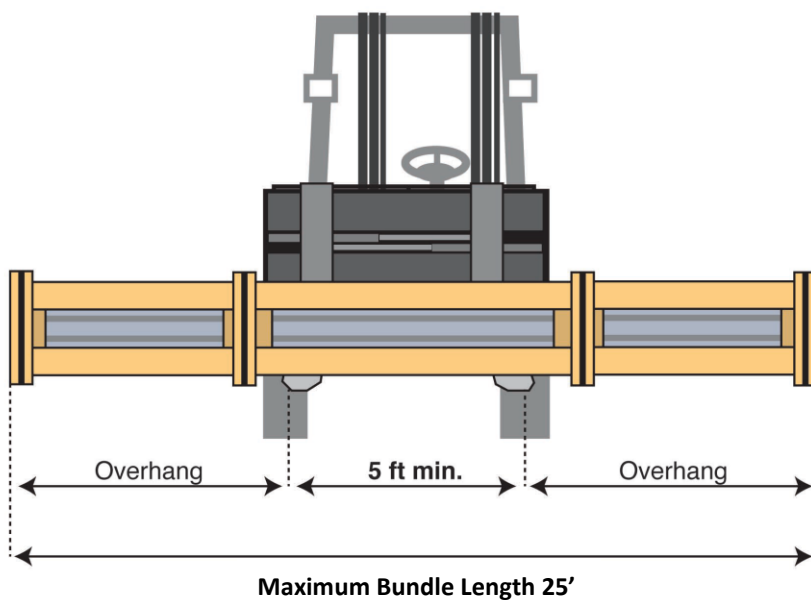
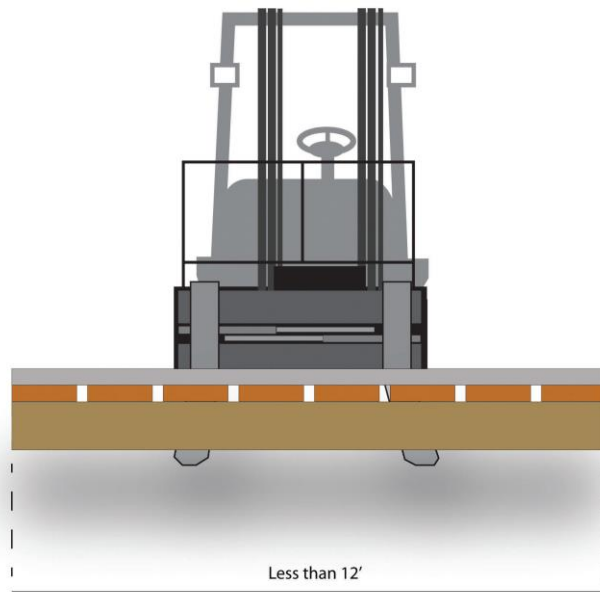



### 5.6 Lifting Roof Panel Bundles

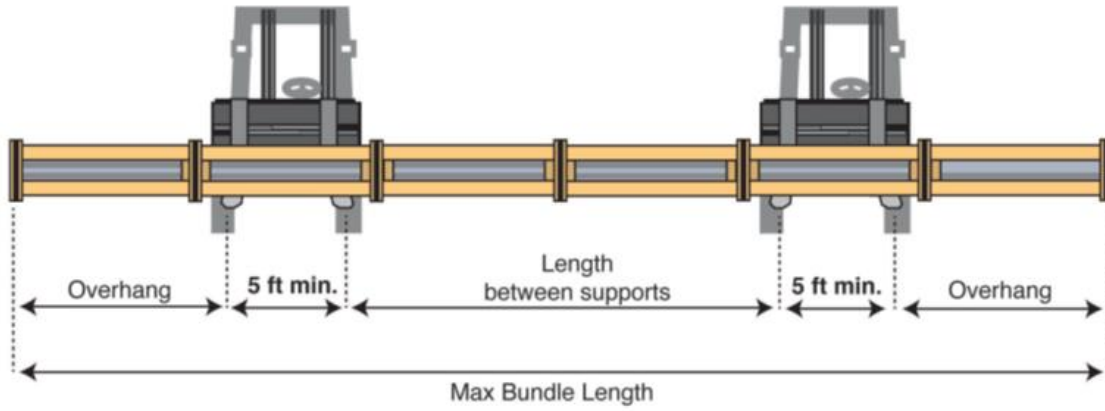

Overhang and Span Limits for Lifting Panel Bundles			
Panel Class	Maximum Overhang (ft.)	Maximum Length Between Supports or Pick Points	Maximum Bundle Length Handled by One Forklift
Non-Structural Panels	5'	10'	15'
Structural Panels	10'	20'	25'

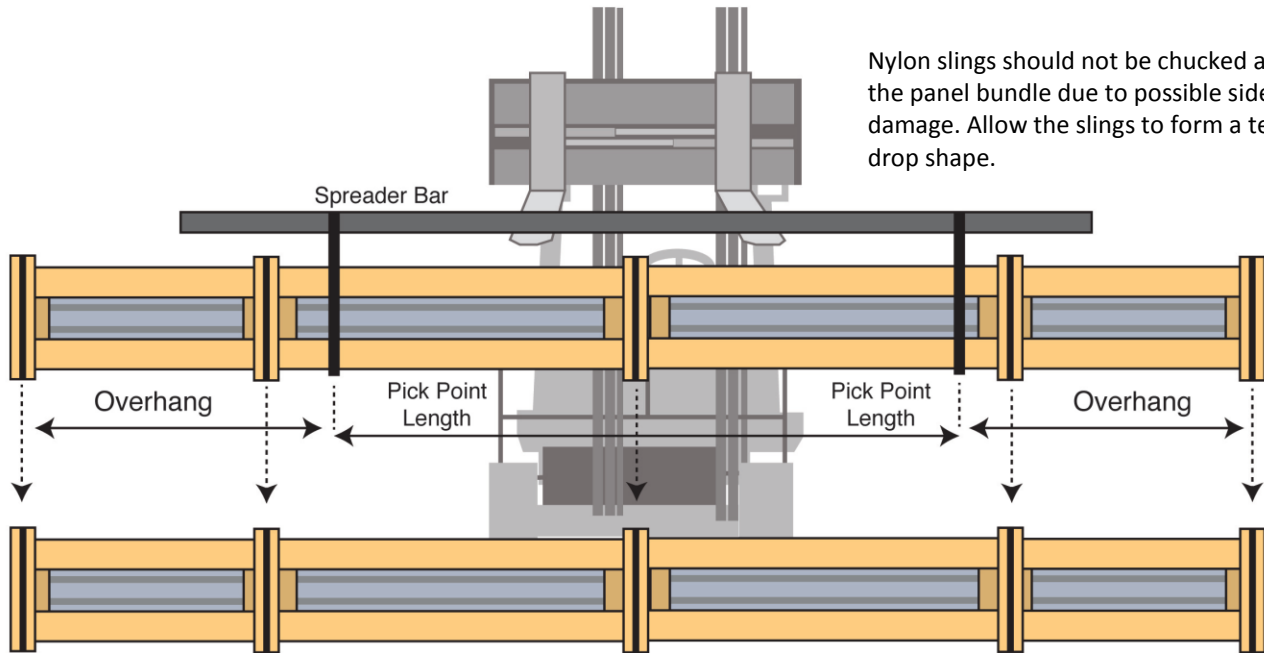

NOTE: Stack bundles so banded wooden frames are supported by banded sections on the bundle underneath.

## 5.6 Lifting Roof Panel Bundles

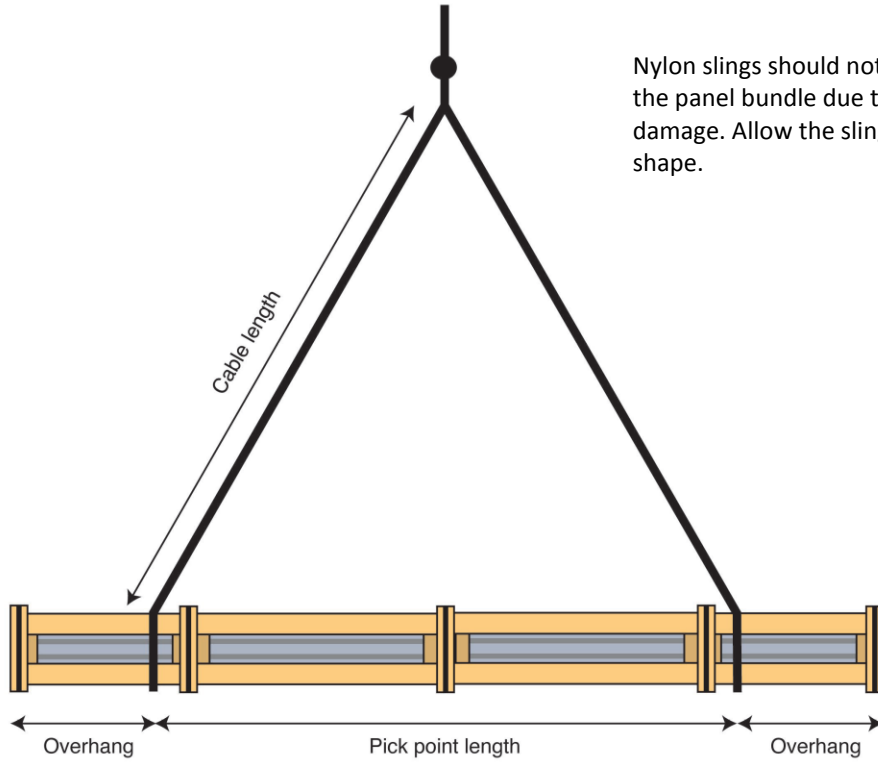

Nylon slings should not be chucked around the panel bundle due to possible side lap damage. Allow the slings to form a tear drop shape.

3 Equal Spaces When Panel Length is 35' or Less  
4 Equal Spaces When Panel Length is More Than 35'

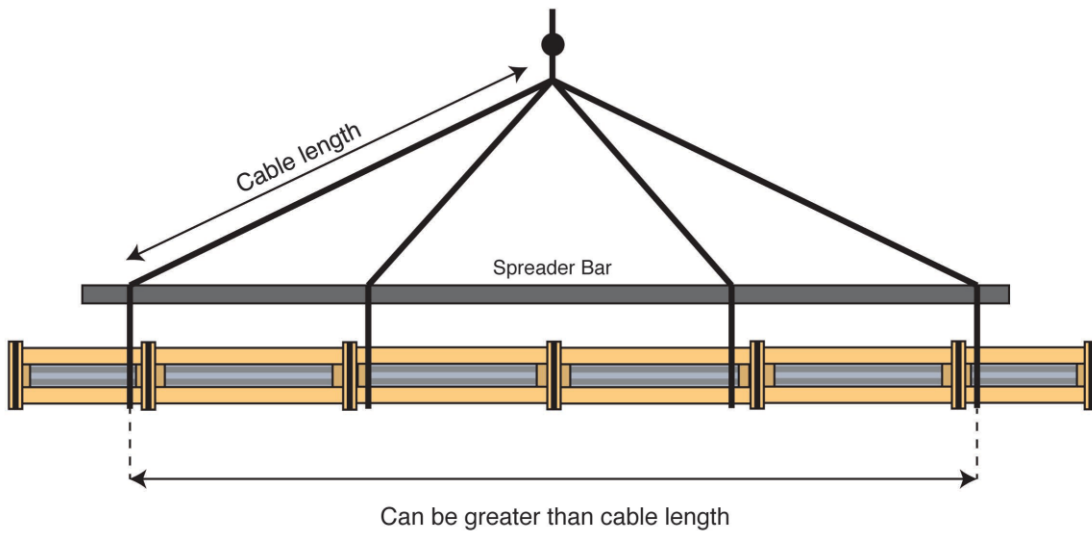

### 5.7 Placing Panel Bundles on the Roof Framing

Locate the bundles on the roof secondary framing according to the erection sequence. The male leg of the roof panel is the leading edge.

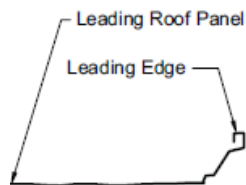

The bundles should be located over the primary structural frame lines, **not** in the middle of a bay. Blocking should be used between purlins at the bundle locations as shown in the detail below. This blocking is not provided by SBS.

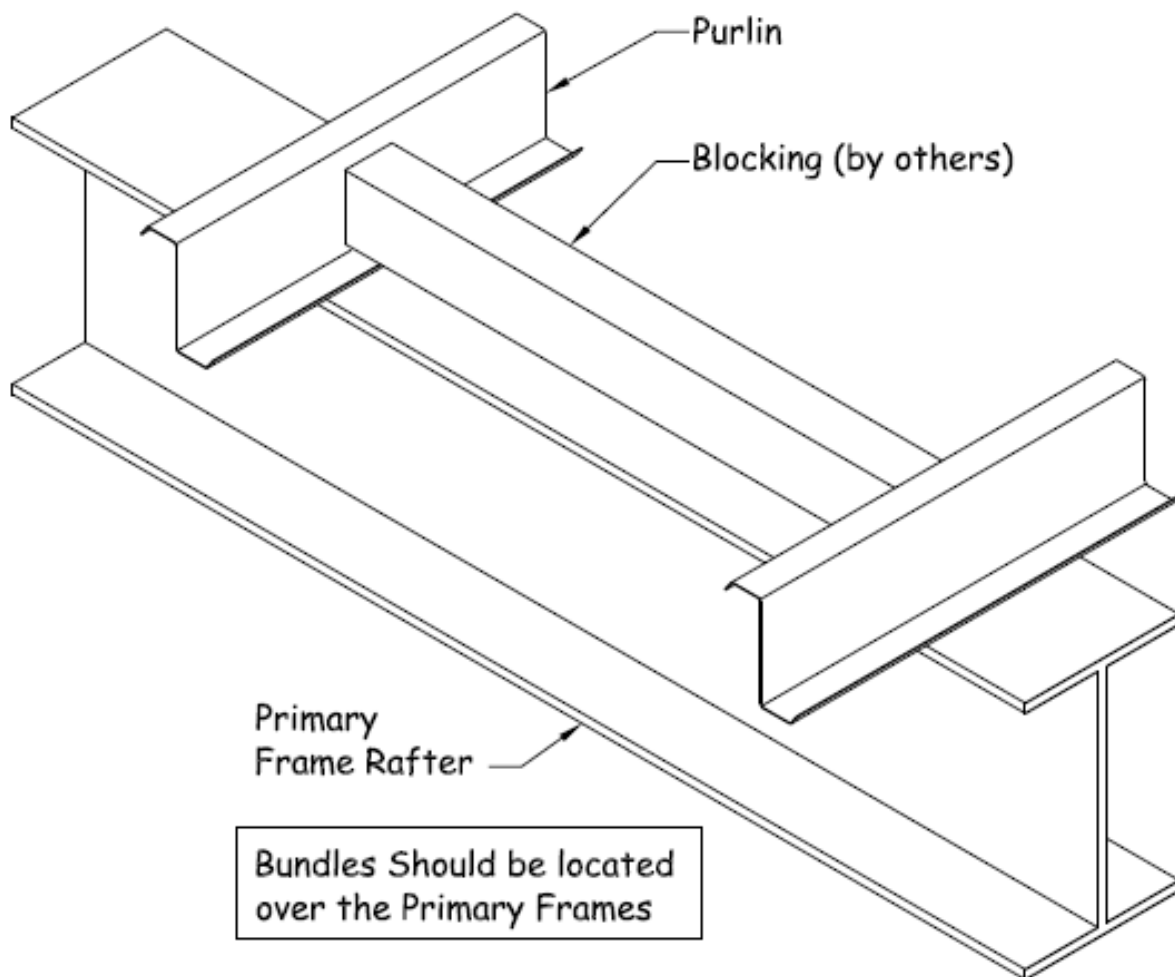

## 6.0 Safe Roof Installation

### 6.1 Regulations

Regulations set forth by the Occupational Safety and Health Act, local, state, and/or federal agencies should be adhered to at all times. SBS is not responsible for injury, damage, or failure, which may be the result from failing to meet any of these regulations.

In compliance with the Hazard Communication Rule 1910:1200, Material Safety Data Sheets (MSDS) have been provided for your use and safety. These data sheets should be made available to all personnel that come in contact with these products. These data sheets will give you the necessary information to properly handle such materials and what to do in case of an emergency. (The MSDS sheets are located in one of the warehouse boxes or you can contact the office for a copy).

### 6.2 Erector's Responsibility

The erector of the roof system is responsible for the safe execution of this manual. These instructions are intended to describe the sequence and proper placement of parts. They are not intended to prescribe comprehensive safety procedures. The procedures in this manual are believed to be reliable. However, SBS shall not be responsible for injury, damage, or failure due to the misapplication of these procedures, improper erection techniques, or negligence.

### 6.3 Walking and Working on Roof Panels

DO NOT place bundles of panels on the roof structure without first verifying the structure will safely support the concentrated weight of the panels and the weight of the installation crew. Some roof structures may not be designed to support the weight of a full panel bundle without additional structure support.

DO NOT use a roof panel as a working platform. An unsecured panel could collapse under the weight of a person standing between purlins or at the panel end.

DO NOT walk on the last installed panel run, as the unsecured edge could collapse under a person's weight. When installing panel clips or making end lap connections, etc., stand where the roof structure will support your weight.

An approved and safe walking platform should be used in high traffic areas to prevent the roof panel from being deformed, scratched, or scuffed.

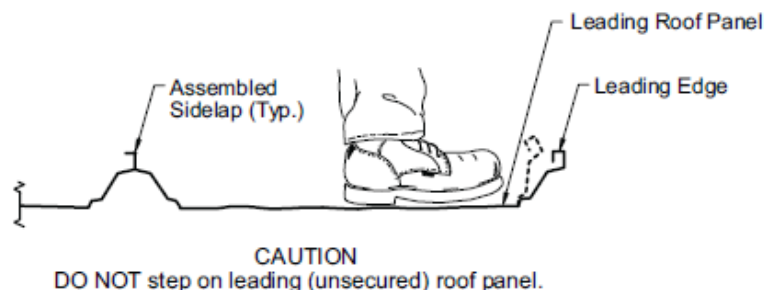
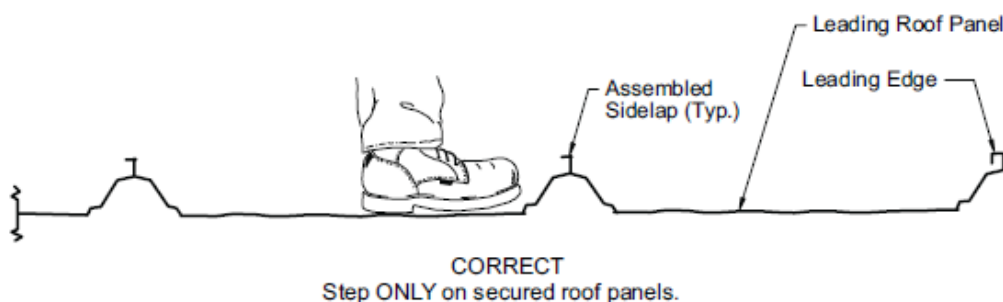

#### 6.4 Safety Equipment

The use of safety equipment for the roof panel installation is recommended at all times during the installation process. However, when using lanyards, ensure that the clasp, belt hooks and wire cables are covered in such a manner that they will not scratch the panel surface if accidentally dragged along the panel.

#### 6.5 Crew Size

The length of the individual roof panels should be considered when determining crew size. It is recommended that under normal conditions, there be one person for every ten feet of panel length, plus one.

#### 6.6 Panel Overhang

**DO NOT** stand on the end of unsupported (cantilevered) panels at the eave or ridge. Standing on the cantilever portion may result in panel collapse.

#### 6.7 Point Loads

When properly supported by the structural steel, panels are designed to support uniform loads, which are evenly distributed over the panel surfaces. Point loads that occur in small or concentrated areas, such as heavy equipment, ladder, or platform feet, etc., may cause panel deformation or even panel collapse.

#### 6.8 Slick Surfaces

Panel surfaces and structural steel surfaces are hard, smooth, and non-absorbent, which causes these surfaces to be very slick when wet or covered with snow or ice. Even blowing sand or heavy dust can make these surfaces difficult to walk on without slipping.

Unpainted panel surfaces are often coated with oil to accommodate the panel-fabrication process. Although designed to wash away or evaporate during normal weather, the oil on new panels can be extremely slick, especially during periods of light rain and dew.

Caution must be exercised to prevent slipping and falling onto the roof surface or even sliding off of the roof. Non-slip working platforms are recommended.

#### 6.9 Electrical Conductance

Metal panels are excellent electrical conductors. A common cause of injury is the contact of metal panels with power lines

during handling and installation. The location of all power lines all must be noted and, if possible, flagged. The installation process must be routed to avoid accidental contact with power lines and high voltage services and equipment. All tools and power cords must be properly insulated and grounded and the use of approved ground fault circuit breakers is recommended.

#### 6.10 False Security of Insulation

Blanket and rigid board insulation block the installer's view of the ground below the roof. Serious injury can occur when the installer gets a false sense of security because he cannot see the ground and steps through the insulation.

#### 6.11 Sharp Edges

Some edges or panels and flashing are razor sharp and can cause severe cuts if proper protective hand gear is not worn. Be careful not to injure others while moving panels and flashing.

#### 6.12 Safe Roof Installation Summary

- **Extreme caution should be exercised when walking on roof panels.**
- **Oils used during the roll forming process and/or natural moisture may cause the panels to become slippery.**
- **Do not step on panels with creased edges.**
- **Do not step on or near the edge of a panel.**
- **Do not step within 5-feet of the end of a panel.**
- **Do not use loose panels as work platforms.**
- **Do not walk on unsecured panels.**
- **Do not walk on translucent panels.**
- **Secure all loose panels at the end of the work day.**
- **Use extra care when working on steep slopes.**
- **When installing clips, walk only over the purlin/joist lines.**
- **At the end of each workday, all full panel runs should be hand crimped into a TripleLok seam profile at the low eave, end lap, high eave, and every clip location.**

**In compliance with the hazard communication rule 1910:1200, material safety data sheets have been provided for your use and safety. These data sheets should be made available to all personnel that come in contact with these products. These data sheets will give you the necessary information to properly handle such materials and what to do in case of an emergency.**

## 7.0 Checking the Structure

### 7.1 Completed and Braced

Before placing materials and workers on the roof structure to start roof installation, it must be confirmed that the structure is designed to accommodate the material and erection loads as well as the appropriate live loads and wind uplift loads.

It also must be determined that the structure is complete and structurally sound with all structural connections and bracing (permanent and temporary) in place and secure.

### 7.2 Lateral Stability

The sliding clip method of attaching roof panels to the roof secondary members provides only limited lateral stability and diaphragm bracing to the roof secondary members.

Before placing materials on the roof and starting the roof installation, confirm that the necessary roof bracing and sag angles or bridging is in place and secured.

### 7.3 Alignment

Prior to installation, roof secondary members should be checked for overall dimensions and evenness or plane. The roof secondary members should also be checked to verify the roof system can be installed without interference. Also, roof secondary members nearest the panel end laps, ridge, or high eave should be checked for correct location to properly accommodate the roof components.

### 7.4 Tolerances

To assure the roof systems correct fit-up and designed weather tightness, the structure must be aligned within the following tolerances; also refer to the MBMA manual for common industry standards.

**OUT OF SQUARE** – The roof system can only accommodate 1/8" of "saw-tooth" of the roof panel ends and the eave, ridge, and panel splices. This means the allowable out of square of the rake line relative to the eave line and ridge line is 1/8" for each 40' of rake run.

**STRUCTURE WIDTH AND EAVE STRAIGHTNESS** – The roof system is designed to accommodate +/- 1" of overall structure width error, or +/- 3/4" of eave straightness error at each eave.

To assure that the accumulation of the structure width error and eave straightness error does not exceed the roof systems tolerance, the structure width should be measured from eave line to eave line at each rake at the first frame line from each rake and at each point where there is a significant error or change in eave straightness. (This usually occurs at a frame line or at a wind column.)

**STRUCTURE LENGTH AND RAKE STRAIGHTNESS** – The roof system is designed to accommodate +/- 2" of overall structure length error, or +/- 1" of rake straightness error at each rake line.

To assure that the accumulation of the structure length error and rake straightness error does not exceed the roof systems tolerance, the structure length should be measured from rake line to rake line at each eave, at the ridge and each point where there is a significant error or change in rake straightness. (This usually occurs at a rafter end splice.)

### 7.5 Measuring

Structure length and width may be measured with a steel measuring tape from the face of the eave or rake member to the face of the opposite eave or rake member. The measuring tape must be parallel to the relative eave or rake line and must be stretched taut. Eave and rake straightness may be determined by measuring deviations from a string line, which is stretched taut along the eave or rake line.

### 7.6 Aesthetic Acceptance

Although these structure alignment tolerances will allow for reasonable roof component fit-up and ease of installation, the extremes of these tolerances may be aesthetically objectionable and should be confirmed with the customer or end owner before starting the roof installation.

### 7.7 Corrections

Any structure alignment error, which exceeds the above stated tolerances, **must** be corrected before roof installation can begin. If it is decided that the structure alignment errors cannot be corrected, alternate roof details may have to be developed. The alternate details may require additional materials, modified parts (with additional cost, fabrication and delivery time) and additional installation time. SBS cannot assure the performance of such alternate details.

## 8.0 Installation Basics

### 8.1 Proper Tools

Before starting the roof installation, be sure that the proper equipment and tools are on hand. The tools must be in good operating condition and operators should adhere to safety precautions at all times.

The following tools and equipment should be considered for efficient installation of the SBS TS-324™ Roof System. Actual tools and equipment required may vary due to variations in building type and construction:

- Horizon TS-324 End Lap Clamp (if required)
- Horizon TS-324 Modularity Clamp
- Horizon TS-324 Panel Modularity Tool
- Horizon TS-324 Manual Crimping/Seaming Tool
- Motorized Seaming Machine (if required)
- Screw Guns – designed for use with self-drilling screws
- Socket Extensions – 6” for screw guns
- Hex Socket Heads – 5/16” w/magnet inserted
- Electric Drill
- Drill Bits- assortment
- Sheet Metal Cutter – or power shears or nibblers
- “C” Clamps – vise grip type
- Pop Rivet Tool – 1/8” capacity
- Sheet Metal Shears – left and right cut
- Hack Saw – with metal cutting blade
- Steel Measuring Tapes – 12’, 50’ 100’ and 120’
- Nylon String Lines
- Blue Chalk Line (NOT red)
- Brooms
- Marking Pens (DO NOT use pencils)
- Caulk Guns – for 1/10 gallon mastic tubes
- Power Source and Extension Cords – capable of handling the total equipment requirement, including 20-amp seaming machine, without power drop due to extension cord length.

### 8.2 Mastic

#### TEMPERATURE EFFECTS

Temperature extremes must be considered during installation of the roof due to the sensitivity of mastics. The recommended installation temperature range is 20 – 120 degrees Fahrenheit. At colder temperature, the mastic stiffens resulting in loss of adhesion and compressibility. At hotter temperatures, the mastic becomes too soft for practical handling. On cold but sunny days, the panel surface may become warm enough to accept the application of heated mastic even though the air temperature is below 20 degrees Fahrenheit.

When overnight temperatures fall below freezing, the mastic should be stored in a heated room so it will be warm enough to use the following day. On hot days, the mastic cartons should be stored off the roof in a cool and shaded area. While on the roof, mastic rolls should be kept shaded until actual use.

In very cold weather, it is recommended that the fasteners be tightened slowly and only tight enough that the mastic is in full contact with the panel or flashing. Then on the next sunny day, complete the tightening process after the sun warms the panel and flashing surfaces.

#### CONTAMINATION

To assure proper adhesion and sealing, the mastic must have complete contact with adjoining surfaces. Contaminants such as water, oil, dirt, and dust prevent such contact. The panel and flashing surfaces must be dry and thoroughly cleaned of all contaminants. Before applying tape mastic, the mastic should be checked for contaminants. If the mastic surfaces are contaminated, it must not be used.

During cool weather, condensation or light mist can accumulate on the panel and flashing surface and not be easily noticed. It is recommended that the mastics always be kept under protective cover and that the panel and flashing surfaces be wiped dry immediately before installation.

Tape mastic is provided with a protective paper to reduce contamination. Incomplete removal of the protective paper will prevent the mastic adhesion to the panel or flashing surfaces. Always check that the protective paper is completely removed. DO NOT remove the protective paper until immediately before the panel or flashing is installed over the mastic.

#### COMPRESSION

To assure proper compression and seal, the tape mastic must be completely and continuously compressed between the panel and flashing surfaces with firm and uniform pressure. In most cases, the required pressure is applied by the clamping action of screws pulling the adjoining surfaces together. However, the tape sealants resistance to pressure becomes greater in cold weather.

During cold weather, the fasteners must be tightened slowly to allow the mastic time to compress. If the fasteners are tightened too fast, the fasteners may strip out before the mastic compresses adequately, or the panel or flashing may deform in the immediate area of the fastener, leaving the rest of the mastic insufficiently compressed.

### INSIDE CORNERS

An inside radius, such as where the panel flat meets a rib, is usually the MOST critical area to seal. A common mistake for the installer is to bridge the mastic across the inside radius.

When the lapping panel or flashing is pushed into place, the bridged mastic is stretched and thinned. The mastic may then be too thin to adequately seal this critical area. When tape mastic is applied at an inside radius, it is recommended that the mastic be folded back, then push the mastic fold into the radius.

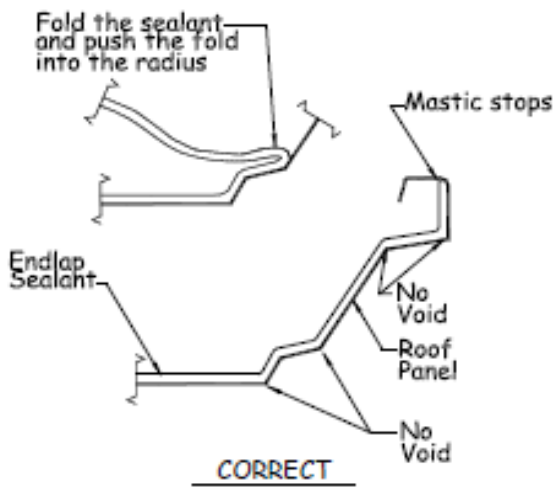
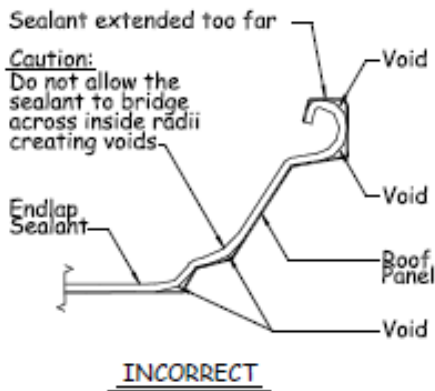

### 8.3 Fasteners

#### SCREW GUNS

Use torque control screw guns for driving self-drilling screws. 2000-2500 RPM screw guns with torque adjustable clutch are necessary to attain efficient drilling speeds. High tool amperage (6-7 AMP) is required to achieve the proper torque for secure fastening. **Do not use impacting tools. Also note that cordless screw guns are not recommended.**

To assure proper voltage to the tool, extension cords should be checked for proper wire size and cord length:

- 16 ga. Wire, max. cord length = 100'
- 14 ga. Wire, max. cord length = 200'
- 12 ga. Wire, max. cord length = 300'

#### SOCKETS

Use good quality magnetic sockets. Good fitting sockets reduce wobble and stripping of the screw heads. They also minimize objectionable paint chipping and scuffing on colored screws and minimize damage to the protective coating on unpainted screws.

Magnetic sockets collect drill shavings, which will build up and eventually prevent the socket from seating properly on the screw heads. One method of removing the drill shavings is to roll up a ball of tape mastic and push the socket into the mastic.

When the socket is removed from the mastic, most of the drill shavings will be embedded in the mastic thereby cleaning the socket. This process should be repeated as often as needed to keep the socket clear of drill shavings.

#### SOCKET EXTENSIONS

A 4" or 6" socket extension is recommended for installing the panel clip screws. With the extension, the screw can be driven straight down without tilting the screw gun to clear the panel or clip.

#### INSTALLATION

Before starting the screw, the materials to be joined must be pressed together with foot or hand pressure. The pressure must be maintained until the screw has drilled through all the materials and the threads have engaged.



**IMPORTANT: Read First**

# SET YOUR MAGNET!

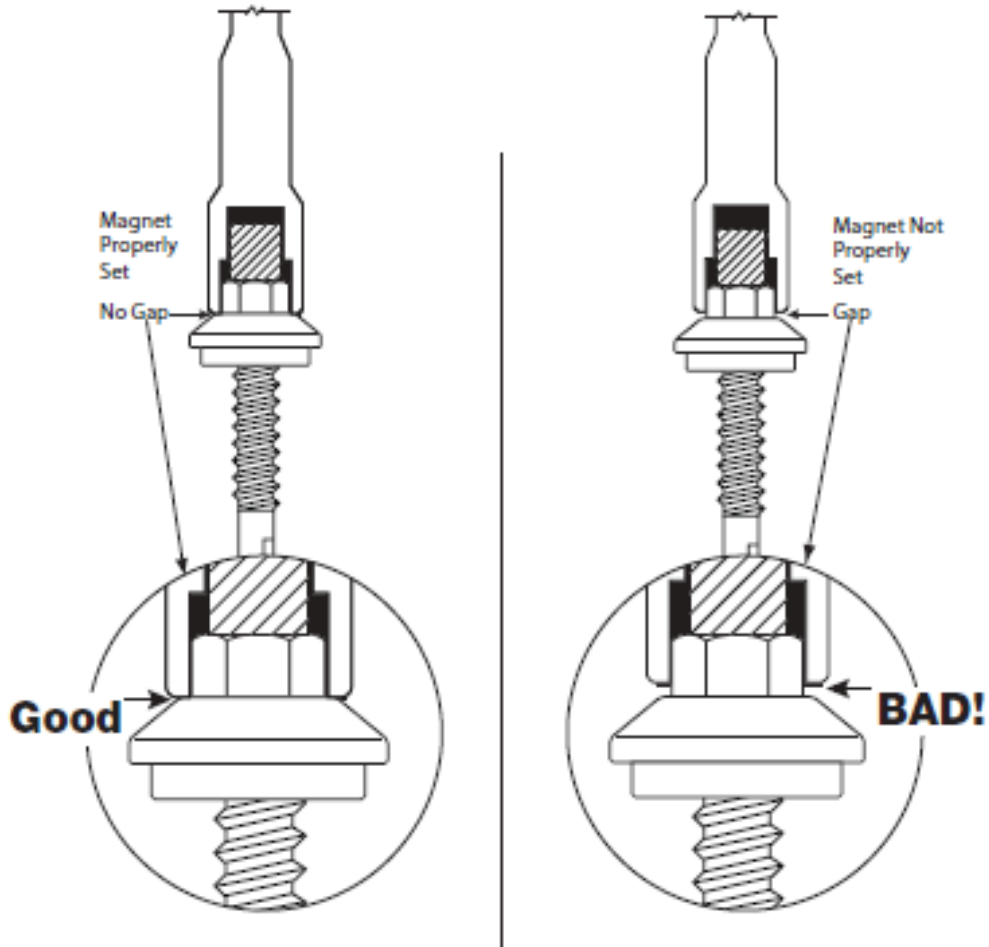

A Magnet **NOT** Properly Set Can Cause:

- Wobble
- Paint and Fastener Head Damage
- Damage To Your Nutsetter
- Installation Difficulty

### 8.3 Fasteners

#### INSTALLATION

Before starting the screw, the materials to be joined must be pressed together with foot or hand pressure. The pressure must be maintained until the screw has drilled through all the materials and the threads have engaged.

Most self-drilling screws require 20 pounds of pressure to maintain the drilling action and to start the thread cutting action. Also, applying such pressure before starting the screw gun will usually prevent tip walking or wandering. If too little pressure is applied, the drill point may not cut into the metal and the point will heat up and become dull. If the pressure is too heavy, the bottom material may be deflected away, causing a standoff condition, or the drill tip may be broken or split. Screws must be held perpendicular to the panel or flashing surface during starting and driving.

For proper seating of the fastener-sealing washer, the panel or flashing surface must be clean and drill shavings must be removed from under washers before seating. The fastener must be driven perpendicular to the panel surface so that the washer can seat level without warping or cupping.

Do not over-drive screws. Over-driving can strip the threads and/or damage the sealing washer. Use a screw gun with torque control set to function properly for the combination of fastener size, hole size, and material thickness.

The fastener should be driven tight enough to uniformly compress the washer but not so tight that the washer splits or rolls out from under its metal dome. The recommended procedure is to tighten the fastener until the sealing washer just starts to visually bulge from under the metal dome. Refer to the chart for a proper fastener-seating diagram.

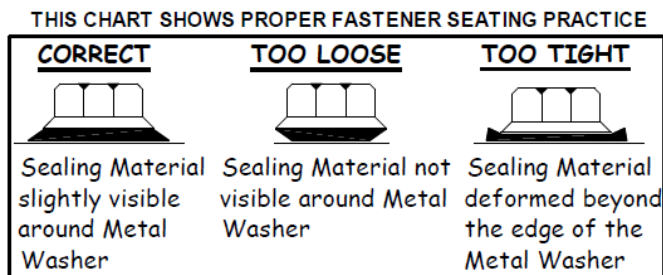

Upon stripping or braking a screw, the screw must be immediately removed and replaced with the next larger diameter screw. Do not defer the screw replacement to be remembered and later fixed, or to be found by the clean-up crew. The majority of such screws are easily overlooked until they cause leak problems later.

### 8.4 Field Cutting of Panels and Flashing

#### ABRASIVE SAW PROBLEMS

Abrasive saws (circular saws with friction disks) are not recommended for cutting roof panels or flashing. Abrasive saws create heat that may burn away the protective cladding from the panel edge, causing the edge to rust.

Also, abrasive saw dust contains fine, hot steel particles which accumulate on panel and flashing surfaces where they rust and can cause staining and rusting of those surfaces.

Rust caused by abrasive saw damage or abrasive dust particles are excluded from warranty claims.

#### SHEARING METHODS

It is recommended that panels and flashing be cut with shears or nibblers to provide a clean, undamaged cut. On shear cut edges, the protective cladding extends to the edge of the cut and is often wiped over the edge to further protect the base metal. Whenever possible, fit the material so that the factory cut edge is exposed and the field cut edge is covered.

When field cutting complex shapes, it is usually easier to cut out a 1-inch wide strip using both left and right hand shears. The 1-inch cutout provides clearance to smoothly cut the flats and the clearance to work the shears around tight corners.

When making repetitive cuts (such as cutting panels at a hip condition) it is recommended that a template be made from a piece of drop-off panel or flashing to provide fast and accurate marking of the field cut. When using panel material for the template, cut off the top portion of the panel ribs so that the template is easily laid onto the panel being marked.

#### MARKING PANELS

Avoid marking the panels for cutting, etc., in a manner that will leave visible markings, stains, etc., on the finished surface. Use chalk or felt tip ink markers. Consider using clothes pins attached to the panel seam to mark problem/unfinished areas. **DO NOT USE GRAPHITE (LEAD) PENCILS ON UNPAINTED PANEL SURFACES; THE GRAPHITE WILL CAUSE RUSTING OF THE SURFACE.**

### 8.5 Sheeting Direction and Modularity

Although the Horizon TS-324™ Roof System is designed so it can be installed either direction (left to right or right to left), there may be roof conditions that require a specific sheeting direction. Check the erection drawings to determine if a specific sheeting direction is required. The required installation sequence is to complete each panel run from eave to ridge **before** starting the next panel run. This sequence will help ensure straight runs and allow the insulation to be installed immediately ahead of each panel run.

During installation of the roof, considerations must be made for maintaining panel width modularity. By maintaining panel width modularity, proper roof coverage can be obtained and the standard perimeter parts will fit properly without necessity of field modifications or reordering of parts, etc.

For proper fit-up between the panel, mastic and closures or end lap parts, the panels must be held to the 24-inch coverage dimension (within a 1/8-inch tolerance per panel). The accumulated coverage (start panel to finish panel) tolerance is determined by the ability to keep the panels parallel and to correctly fit and assemble the finish rake condition.

If the roof panel has conditions such as fixed location penetrations, parapets, firewalls, etc., the accumulated panel coverage may require tighter tolerances for proper fit-up and weather tightness of the roof system.

IN ORDER TO MAINTAIN ROOF PANEL MODULARITY, IT IS REQUIRED TO INSTALL THE OUTSIDE CLOSURES IN THE PREVIOUS PANEL RUN. IF THE OUTSIDE CLOSURES ARE NOT INSTALLED IN THE PREVIOUS PANEL RUN, IT WILL BE DIFFICULT TO HOLD MODULARITY AND TO ACHIEVE PROPER WEATHER TIGHTNESS. ALSO, IMPROPER INSTALLATION CAN VOID YOUR WARRANTY. NOT INSTALLING OUTSIDE CLOSURES USING THIS METHOD WILL ALSO ADD A SIGNIFICANT AMOUNT OF FIELD WORK LATER ON.

It is also recommended to use panel modularity tools and panel clamps to help hold proper coverage.

It is also recommended to pre-drill the secondary framing to help hold proper panel width coverage.

### 8.6 Layout and Checking Coverage

Recommended for all roofs, but a must for large or complex roofs, is to make a layout of the actual structure (field measured as described in sections 7.4 – 7.5) so that the roof panel start and finish dimensions can be laid out to accommodate any structural misalignments.

Panel coverage is always checked at the eave, ridge, and end laps so that non-parallel seam (or dog-leg) conditions can be detected and corrected before they become objectionable. The coverage check should be one with a measuring tape held taut and measured to the same side of the seam and always parallel to the eave to prevent any measuring error.

Every four to six panel runs should be checked for panel width modularity. This will assure that the panels are maintaining a straight line and proper coverage is being maintained. If the panels are off module, they should be corrected by equal adjustments of the next four to six panel runs.

### 8.7 Appearance Considerations

Although the above stated coverage tolerance will provide for reasonable ease of installation and weather tightness, such visible conditions as non-parallel panel seams, dog-leg of the panel seam at the end laps, non-parallel finish panel width, and mis-match of panel seams across the ridge may be objectionable and should be confirmed with the customer before continuing the roof installation.

### 8.8 Inspection of the Roof Assembly During Installation

#### IMPORTANCE OF INSPECTION

During the roof installation, all areas of the roof system must be frequently inspected to ensure the correct assembly in accordance with the erection drawings and this manual.

**Failure to assemble the roof system correctly will result in roof performance problems that may require costly corrective work, roof replacement and performance and drainage claims, etc. Also, incorrect installation may void the material and weather tightness warranties.**

**8.9 Inspection List (A Partial List to Review)** The Installation Guide and Erection Drawings MUST be followed.

#### ERECTOR DRAWINGS

Check that the erection drawings are available at the job site and have been reviewed for differences with the actual job conditions and differences with the erection manual. Also confirm that the drawings are the latest issue with the latest revisions and additions.

#### ROOF LAYOUTS

Check that the roof start and finish dimensions have been correctly determined based on the erection drawings and the actual structural conditions.

#### STRUCTURAL ALIGNMENT

Check that the structural mis-alignments were corrected in accordance with section 7.3 of this manual.

#### PANEL LENGTH

Check that the installed roof panels have the correct overhang at the eave and end laps and have the correct hold back dimension at the ridge or high eave, in accordance with the erection drawings.

#### EAVE SEAL

Check that the eave mastic is in the correct position on top of the eave plate and that the void closure and 3" pre-cut mastic are correctly placed. Check that the eave fasteners penetrate the center of the eave mastic and into the eave plate. Check that the fasteners are not loose or stripped.

Check that the eave mastic is in complete contact with the roof panel and eave plate without any voids or gaps. Confirm that the roof panel and eave plate are clean and dry during installation and that the mastic is not wet or otherwise contaminated.

#### END LAP SEAL

Check that the roof panel end laps are correctly assembled and that the lapping panels are tightly nested without visible gaps.

Check that the mastic is in the correct position and is in complete contact with the lapped panels without any voids or gaps, especially at the radius between the panel flat and the vertical legs of the panel. Confirm that the panels are clean and dry during installation and that the mastic is not wet or otherwise contaminated.

Check that the end lap fasteners penetrate through the center of the mastic and into the backup plate. Check that the fasteners are not loose or stripped.

Check that the end lap assembly is not bowed down causing water ponding and debris accumulations.

#### RIDGE SEAL

Check that the outside closure assembly is correctly installed.

Check that the mastic is in the correct position and is in complete contact with the outside closure and the roof panel without any voids or gaps. Confirm that the outside closure and roof panels are clean and dry during installation and the mastic is not wet or contaminated.

Check that the outside closure fasteners penetrate through the center of the mastic and into the backup plate. Check that the fasteners are not loose or stripped.

#### RAKE SEAL

Check that the mastic between the rake trim and the roof panel is properly installed.

Check that the rake trim end caps are installed properly.

Check that the flashing splices are correctly lapped, sealed and fastened.

Check that all fasteners are seated properly.

#### PANEL CLIP ATTACHMENT

Check that the panel clips are correctly fitted to the panel without any distortion or damage of the clip tab. On sliding clips, check that the self-centering clip tab is centered on the clip base between the centering tabs.

Check that when installing the sliding clips that the self-centering clip tab is dis-engaged and the screws are fully secured to the clip base supports.

Check that the clips are located along each panel side lap at each roof secondary member or at the locations specified on the erection drawings.

Check that the panel clip fasteners are of the type, size, length, finish and quantity per clip as specified on the erection drawings.

Check that the panel clip fasteners are not loose or stripped. In the case of composite roof construction, verify that the fasteners penetrated and engaged the specified roof secondary member.

#### SIDE LAP

Check that the factory installed side lap mastic is in the correct position without voids or interruptions and is not damaged, wet or otherwise contaminated. Replace missing side lap mastic with Butyl tube caulk.

Check that the full length of each side lap is correctly engaged, hand crimped and /or seamed.

Check that the panel coverage tolerance does not exceed 1/8-inch per panel and that the accumulated coverage will allow proper fit and assembly of the outside closures and finish rake conditions such as penetrations, parapets, etc.

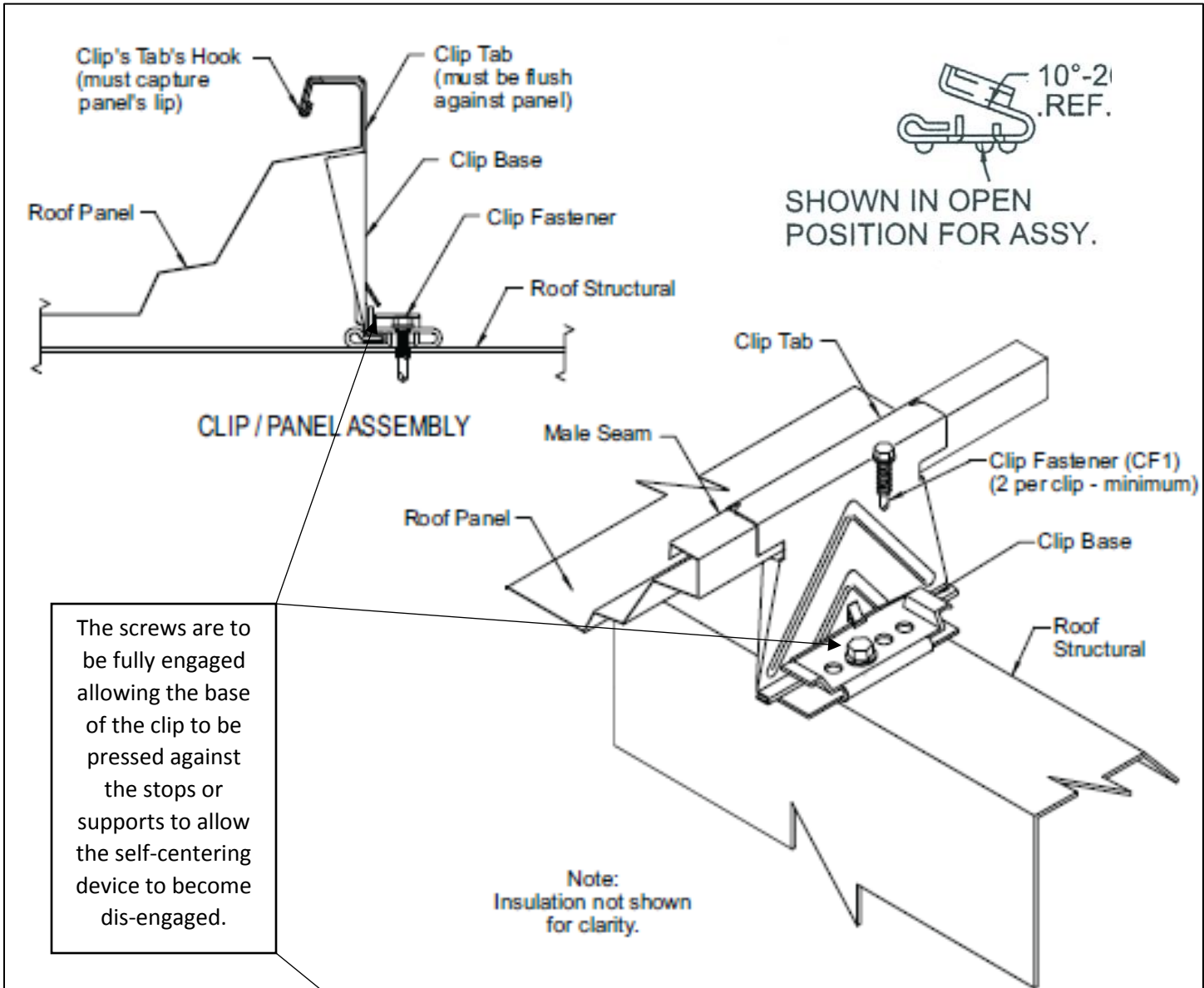

The screws are to be fully engaged allowing the base of the clip to be pressed against the stops or supports to allow the self-centering device to become dis-engaged.

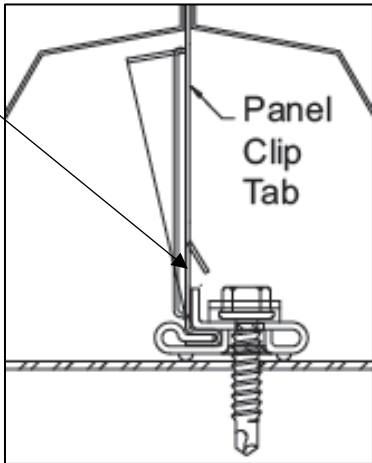

#### FLASHING AND PENETRATIONS

Check that all flashing (including penetrations) are correctly assembled and tightly fitted. Check that the required mastics are correctly positioned and in complete contact with the adjoining surfaces without voids or interruptions. Confirm that the mastics and adjoining surfaces are clean and dry during installation.

Check that the flashing splices are correctly lapped, sealed and fastened.

Check that the flashing is sufficiently pitched to shed water and eliminate ponding areas, especially at the critical splices, end laps and corners.

Check that the fasteners are of the specified type, size, length, finish and spacing. Check that the fasteners are not loose or stripped. Check that the sealing washers are in full contact with the flashing surface and not distorted, split or otherwise damaged.

Along the rakes, high eave transitions, fixed penetrations, etc., check that the flashing is not constrained and will allow for the roofs thermal expansion/contraction.

#### UNSPECIFIED MATERIALS

Use of the wrong materials may cause installation and performance problems and may void the performance and material warranties.

Check that all installed roof system materials, especially mastics and fasteners, are ONLY those which are provided or specified by SBS for your specific project and are used only as specified on the erection drawings and this installation guide.

**SBS cannot be responsible for the performance of roof materials that are not provided, specified or approved by SBS.**

#### SURFACE CONDITIONS

Damaged roof system surfaces are subject to corrosion and performance problems and may void the material and performance warranties.

Check that the panel and flashing surfaces are not being subjected to abusive conditions such as: careless handling of panels and flashing, excessive roof traffic, abrasive or contaminated footwear, rough handling of materials, tools and equipment, or contact with abrasive materials or residue, etc.

Check that the panel and flashing surfaces are not being subjected to exposed metal objects and material left on the roof such as: tools, material drop-off, fasteners, wire, staples, drill and nibbler chips, saw and file particles, etc. In the process of rusting, these materials will absorb the panels protective coating, thus leaving the panels exposed to rusting.

Check that the panels and flashings are not being subjected to long term wet conditions such as: standing water, consistent sources of steam, mist, spray, dripping or run-off, wet debris, wet insulation or other moisture holding material.

Check that the panels and flashings are not subjected to direct contact or run-off from corrosive materials such as: copper pipes and flashing, uncured cement, treated lumber, anti-icing chemicals, galvanized materials, strong solvents or other corrosive materials.

Check that graphite (lead) pencils were not used to mark on unpainted surfaces. The graphite marks will cause rusting.

Check that the roof materials are not subjected to damaging heat such as: Cutting torches, abrasive saws, etc.

#### HAND CRIMPING & MOTORIZED PANEL SEAMING

As the roof installation progresses, **it is required** to hand crimp and/or mechanically seam the previous full panel run. Seaming options differ per project. Refer to the erection drawings for specific seam requirements. Then review the details in sections 10.2, 12.3, and 17.4 of the Seaming Manual.

***Horizon Building Systems cannot be responsible for the performance of roof materials that are not provided, specified or approved by Horizon Building Systems.***

#### IMPORTANT NOTE:

As a minimum requirement, the roof should be hand crimped into a RollLok profile (TripleLok) at the low eave, end lap, high eave, and every clip location at the end of each workday. **Failure to do so may result in panels coming off of the roof due to high winds. It is also required before the seamer can be operated successfully.**

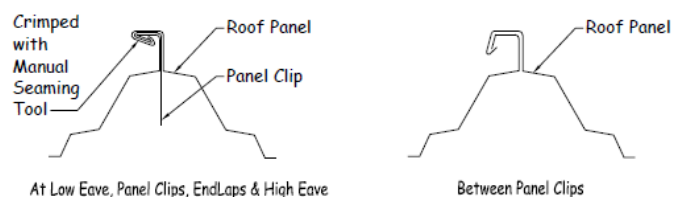

### **8.10 Roof Leak Troubleshooting & Potential Causes of Roof Leaks**

THE ERECTOR DOES NOT LOCATE AND READ THE Horizon TS-324™ ERECTION MANUAL AND ERECTION DRAWING INSTRUCTIONS.

The erection manual defines the standard details required for installing the Horizon TS-324™ Roof System. Reading the erection manual and drawings will actually improve the productivity and quality of your work. SBS has included the benefit of years of testing and feedback from many installers who have installed millions of square feet of Horizon TS-324™ Roof. Be cautious with anyone who tells you that their experience allows them to deviate from the tried and true instructions found in our erection manual and erection drawings.

THE BUILDING INSULATION IS NOT PROPERLY TIED OFF TO FORM A VAPOR BARRIER, ALLOWING THE ROOF TO CONDENSATE.

Condensation occurs when warm moist air comes in contact with colder surfaces such as panels, framing members, etc. The insulation system must be designed to act as a vapor barrier in addition to providing thermal values. It is the erectors responsibility to install the insulation properly, according to normal and customary industry practices.

THE BACKUP PLATE AT THE END LAP IS NOT PROPERLY INSTALLED OR ALIGNED.

If the tabs on the backup plate are not properly attached over the end of the roof panels, the backup plate will push away and not allow the end lap fastener to engage properly. SBS recommends the panel to be fully seated into the alignment tabs on the backup plate to align the end lap components. Be sure not to penetrate the vinyl insulation backing.

THE 28-INCH PRE-CUT MASTIC AT THE END LAP IS NOT PROPERLY LOCATED.

The center of the end lap mastic is placed in alignment with the factory pre-punched holes on the panels. This allows the fasteners that are installed in the pre-punched holes to properly penetrate the tape mastic.

STRIPPED FASTENERS AT THE END LAPS, JOINTS, RAKE, EAVE, RIDGE, ETC.

It is important that if a fastener is stripped, it is replaced with one of a larger size diameter to ensure the proper tightening and clamping force is achieved.

THE OUTSIDE CLOSURES ARE NOT INSTALLED AS THE ROOF IS PUT DOWN AND/OR THEY ARE NOT PROPERLY SEALED.

If the proper installation procedure is not followed, the coped area of the panel will not be sealed and moisture build up from ice and snow or driving rain may infiltrate the building. Refer to the SBS erection manual section (13.8 – 13.11) for instructions. The outside closures must be installed in the prior full panel run. The outside closures are aligned and fastened together and sealed.

MASTIC IS NOT APPLIED PROPERLY AT THE LOW EAVE VOID CLOSURE.

Mastic is to be placed above the void closure at the eave of the building. Additionally, care must be taken to ensure the void closure is centered under the corrugation of the roof panel.

INCORRECT CAULKING TYPE USED AT THE ROOF LOCATIONS.

The tube sealant is required to be applied at certain locations as directed in the erection drawings and manual.

HOLES IN THE ROOF PANELS

Most of the time, holes in the roof panels are from objects being dropped or thrown onto the panels. These include screw guns, outside closures, backup plates, clips, etc. Small holes can be repaired with a piece of panel material sealed with tape mastic or tube sealant and screwed in place. Large holes should be repaired by replacing the roof panel.

PRE-CUT MASTICS NOT APPLIED AT END LAPS AN OUTSIDE CLOSURES

3-inch pre-cut mastic has been supplied to be applied along the notched trapezoidal panel sections at the end lap assembly and at the outside closure assembly. Follow the directions closely during installation of the roof to assure that these mastics are applied.

## 9.0 Standard Hardware Parts

### 9.1 General

The following details provide a basic description and graphic illustrations of the standard roof assembly parts. The purpose of these details is to assist the erector in the correct selection and identification of parts.

Because of the many variations in conditions, it is important that you review the job conditions to identify the specific parts for your job.

Review the erection drawings for any special parts or parts which are different from the standard parts shown in these details. If differences exist, the erection drawings will take precedence.

For proper fit up, sealing, fastening, and to help ensure the roof assembly is weather tight, structural capability, durability and aesthetically pleasing, the correct parts must be used. Do not use parts other than those specified on the erection drawings.

- ROOF PANEL (24" wide panel)**
- 24 or 22 gauge Steel
  - Painted or Galvalume Finish
  - Ribbed Pan
  - Factory notched for endlap
  - Factory punched holes

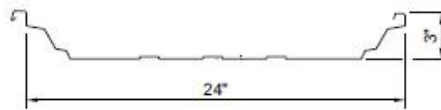

Part No. TS324  
(Specify gauge, finish & length)



**9.2 Standard Parts**

**FIXED CLIP (for 0" stand-off) (Utility)**  
 • 20 ga. Galvanized Steel

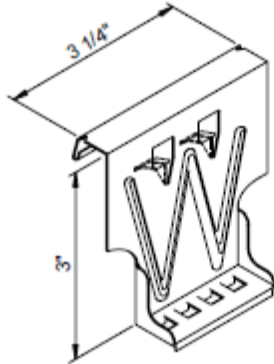

Part No. FC461

**Low Floating Clip**  
 (for 3/8" stand-off)  
 20 ga. Galvanized Steel, tab  
 16 ga. Galvanized Steel, base

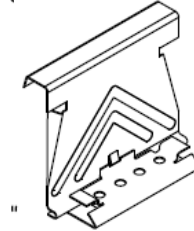

Part No. MPS602S

**FIXED CLIP**  
 (for 3/8" stand-off)  
 • 20 ga. Galvanized Steel

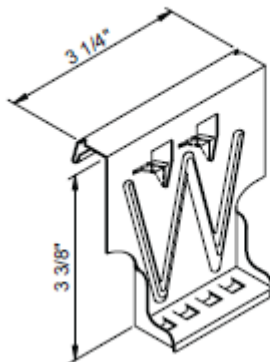

Part No. FC462

**Tall Floating Clip**  
 (for 1-3/8" stand-off)  
 20 ga. Galvanized Steel, tab  
 16 ga. Galvanized Steel, base

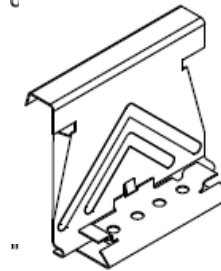

Part No. MPS603S

**FIXED CLIP**  
 (for 1-3/8" stand-off)  
 • 20 ga. Galvanized Steel

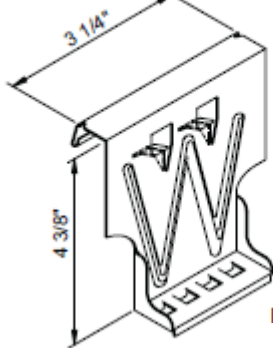

Part No. FC463

Stand-Offs  
 3"



MPS-609

## 9.2 Standard Parts

### INSIDE CLOSURE

- 18 gauge Steel
- Galvalume Finish
- Factory punched holes



Part No. ISC324

### OUTSIDE CLOSURE

- 24 gauge Steel
- Painted or Galvalume Finish



Part No. OSC324 (Specify finish)

### ENDLAP CINCH STRAP (for 24" wide panel)

- 18 gauge Stainless Steel
- Factory punched hole



Part No. CS324

### ENDLAP BACK-UP PLATE

- 16 gauge Galvalume Steel
- Factory punched holes



Part No. BUP324

### RAKE ANGLE

16 Gauge Steel  
Galvanized

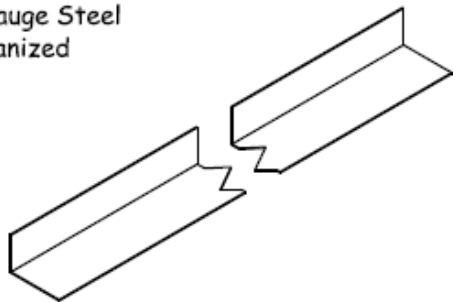

Length = 20'-0"  
Width =  
Height =

Part No. SA(\_)

### WALL RAKE ANGLE

16 Gauge Steel  
Galvanized

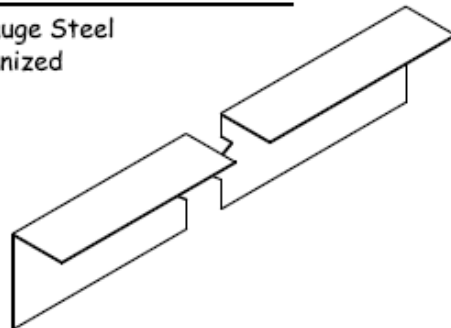

Length = 20'-0"  
Width =  
Height =

Part No. SA(\_)

## 9.2 Standard Parts

**EAVE PLATE** (for 3/8" stand-off)  
 • 16 ga., 50 ksi Galvanized Steel  
 • 10'-0" length

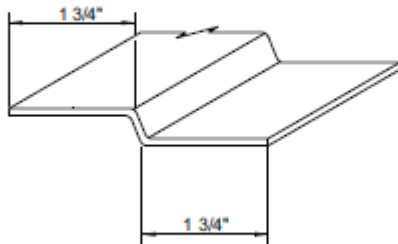

Part No. EP038

**FLOATING RAKE PLATE**(for 3/8" stand-off)  
 • 16 ga., 50 ksi Galvanized Steel  
 • 10'-0" length  
 • Factory punched slots

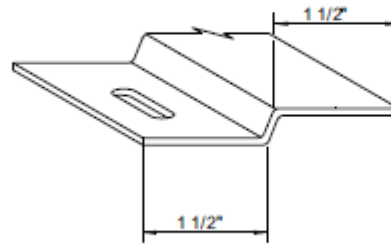

Part No. RP038

**EAVE PLATE** (for 1 3/8" stand-off)  
 • 16 ga., 50 ksi Galvanized Steel Min.  
 • 10'-0" length

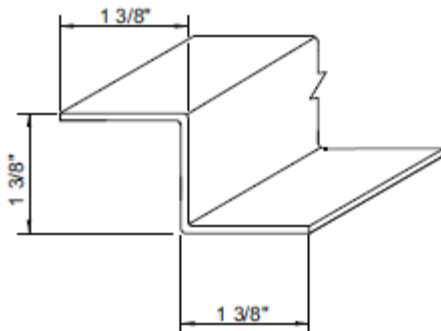

Part No. EP138

**FLOATING RAKE PLATE** (for 1 3/8" stand-off)  
 • 16 ga., 50 ksi Galvanized Steel Min.  
 • 10'-0" length  
 • Factory punched slots

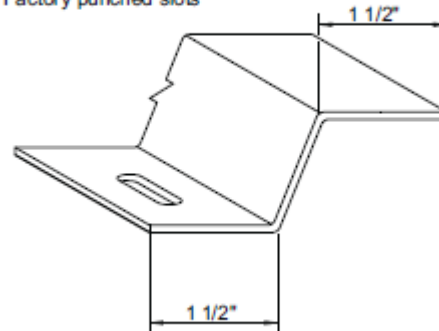

Part No. RP138

**Floating Eave Plate** (for 3/8" stand-off)  
 16 ga., 50 ksi Steel  
 10'-0" length

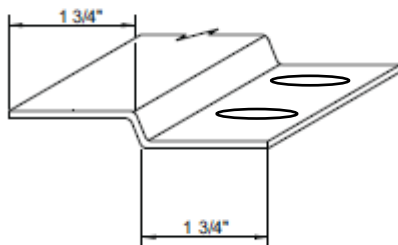

Part No.

**Floating Eave Plate** (for 1-3/8" stand-off)  
 16 ga. 50 ksi Steel  
 10'-0" length

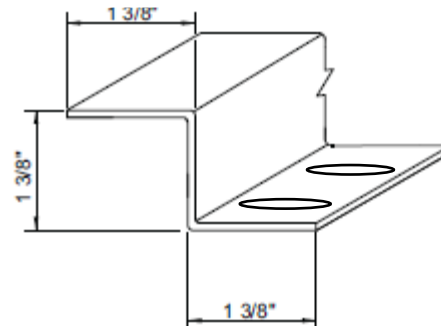

Part No.

## 9.2 Standard Parts

### RAKE SUPPORT ANGLE (For 3/8" Stand-Off)

- 16 gauge Steel
- Red Oxide
- 20'-0" length

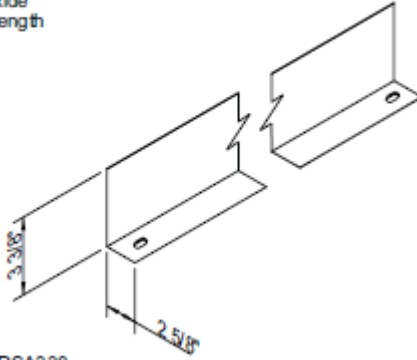

Part No. RSA338

### RAKE SUPPORT ANGLE (For 1 3/8" Stand-Off)

- 16 gauge Steel
- Red Oxide
- 20'-0" length

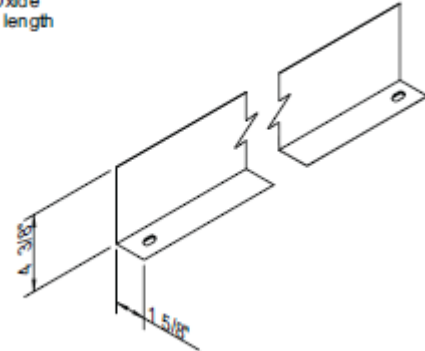

Part No. RSA438

### CLIP FASTENER

(for panel clip & eave plate attachment to steel purlins)

- 1/4"-14 x 1 1/2" hex head, Self Drilling Screw
- Corrosion resistant plating

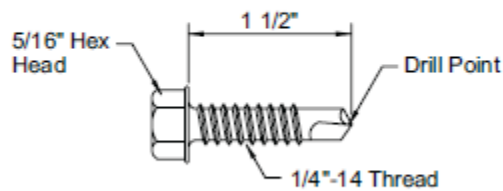

Part No. CF1

### SHOULDER FASTENER

(for rake support angle attachment to steel purlins)

- 1/4" - 14 x 1 1/4" hex head, Self Drilling Screw
- Shoulder feature
- Corrosion resistant plating

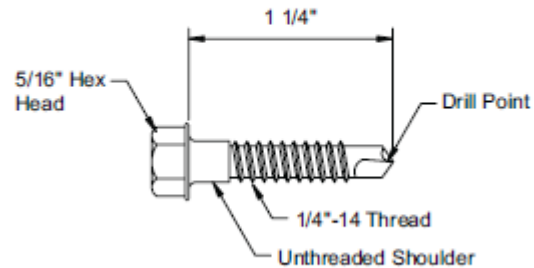

Part No. SF1

### CLIP FASTENER

(for panel clip attachment to metal decking)

- #12 - 13, Phillips drive, Truss Head Screw
- Corrosion resistant coating

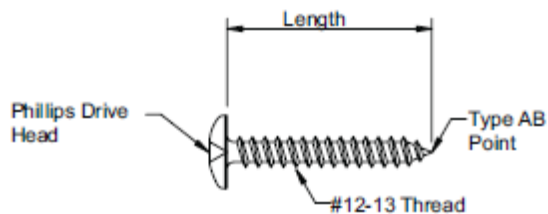

Part No. CF2 (Specify length)

### ROOF FASTENER

(for rake angle to metal purlins)

- #10 - 16 x 1" - Phillips drive, Pancake Head Screw
- Corrosion resistant coating



Part No. RF1

## 9.2 Standard Parts

### CLIP FASTENER

(for panel clip attachment to wood decking)

- #10 - 12, Phillips drive, Pan Head Screw
- Corrosion resistant coating

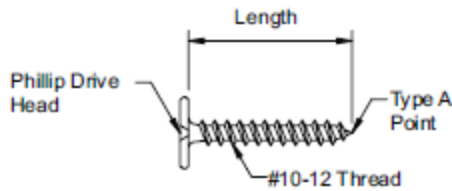

Part No. CF3 (Specify length)

### ROOF FASTENER

(for panel edge attachment) (long life)

- 1/4 - 14 x 1 1/4" hex head, Self Drilling Screw
- EPDM Sealing Washer
- Corrosion resistant coating or alloy head
- Painted or mill finished head

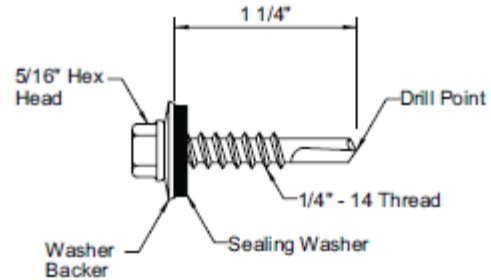

Part No. RF2 (Specify finish)

### LAP FASTENER (for flashing attachment) (long life)

- 1/4" - 14 x 7/8" Self Drilling Screw
- EPDM Sealing Washer
- Corrosion resistant coating or alloy head
- Painted or mill finish head

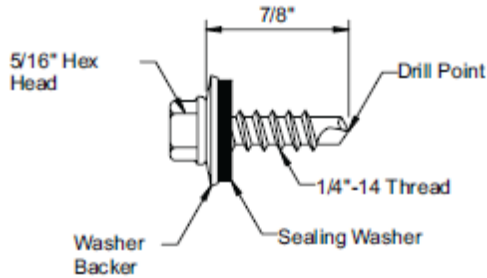

Part No. RF3 (Specify finish)

### BLIND RIVET (for flashing joints)

- Stainless steel
- 1/8" dia. x 3/16" length

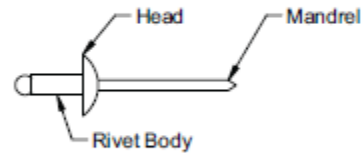

Part No. RF4

### SELF-TAPPING SCREW

No. 17-14x1 1/4" W/ Sealing Washer  
"GOOF-SCREW"

LONG LIFE FASTENER - 3/8" HEAD

- Recommended Tool Types:  
(High Torque, Low RPM) Torque Adjustable Clutch  
-DO NOT use Impacting Tools



Used at locations where fastener has stripped out.

Part No.

### INSULATION RETAINER WASHER

1 1/4" Steel Flat Washer with 5/16" diameter hole



Used with self-drilling screws to attach insulation at the building eave.

Part No.

**9.2 Standard Parts**

28" Pre-Cut End Lap Mastic  
 3/16" X 1 1/2"  
 3 Strips per Sheet  
 Protective Paper Backing

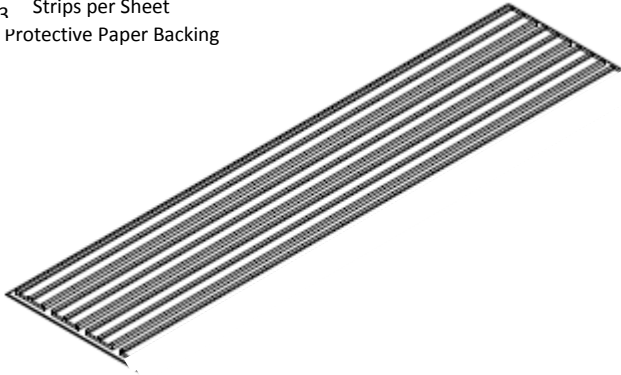

Width = 1 1/2"  
 Thickness = 3/16"

Part No. RS1-28

**TAPE MASTIC**

Isobutylene Tripolymer  
 30'-0" Roll

For over the outside closure and  
 along the low eave

Width = 1 1/2"  
 Thickness = 3/16"

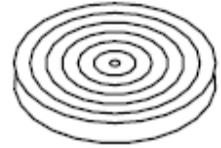

Part No. RS1

**TAPE MASTIC**

Isobutylene Tripolymer  
 45'-0" Roll

For rake, sliding rake and gutter

Width = 1/2"  
 Thickness = 3/32"

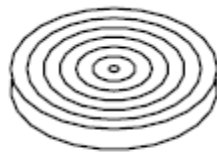

Part No.  
 RS45-H

**8" PRE-CUT MASTIC**

3 Strips Per Sheet  
 Protective Paper Backing

For Void Closures and gutter  
 support bracket

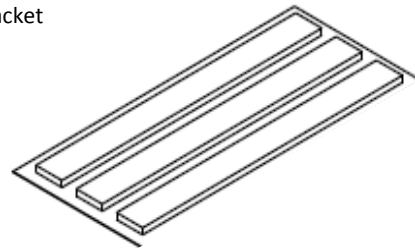

Width = 1 1/2"  
 Thickness = 3/16"

Part No. RS8

**SELF-DRILLING SCREW**

No. 12-24x 1 1/2" TCP5 W/O Washer

5/16" HEAD

Recommended Tool Types:

- 2000 RPM; Torque Adjustable Clutch
- 4 Amp or Higher Rated Tools
- DO NOT use Impacting Tools



Used to attach panel clips,  
 rake angle clips, and rake angle  
 to joist.

9.2 Standard Parts

3" PRE-CUT MASTIC

3 Strips Per Sheet  
Protective Paper Backing

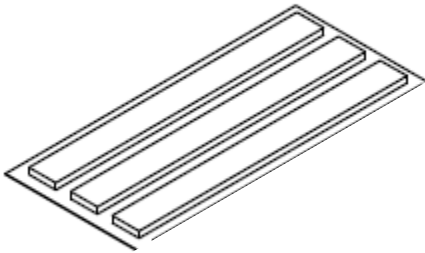

Width = 1 1/2"  
Thickness = 3/16"

Part No. RS3

BUTYL TUBE CAULK

Roof Applications

Provides 23'-0" lineal feet with  
a 1/4" to 3/8" bead size

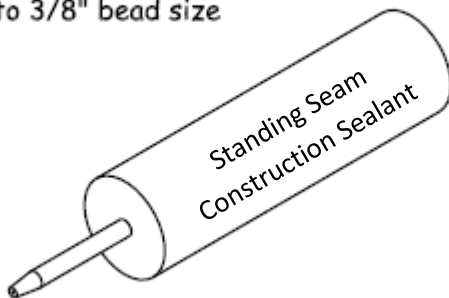

Part No.

MS TUBE CAULK

For Use at trim Laps and roof  
penetrations

Provides 23'0" lineal feet with a  
1/4" to 3/8" bead size

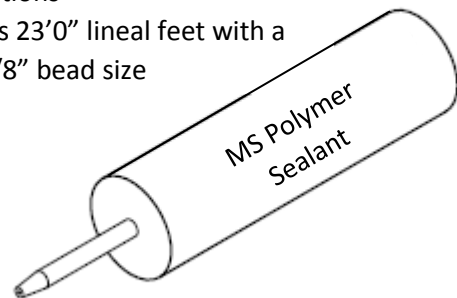

Labeled MS Polymer or  
Permathane

Part No.

9.2 Standard Parts

THERMAL BLOCK

Expanded Polystyrene

For tall clips where insulation thickness is between 4 and 10-inches in thickness

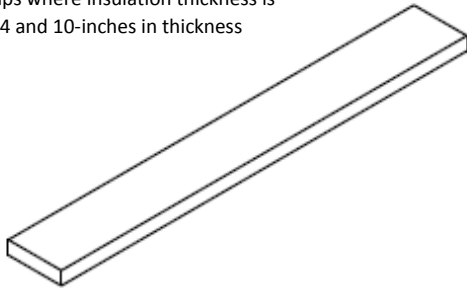

Length = 23"  
Width = 3"  
Height =

Part No. \_\_\_\_\_

EPS FOAM SPACER

Expanded Polystyrene  
50'-0" Roll

For when short clips are used with no insulation

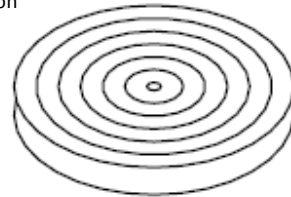

Width = 2 1/2"  
Thickness = 1/2"

Part No. \_\_\_\_\_

9.3 Accessory Tools

MODULARITY CLAMP

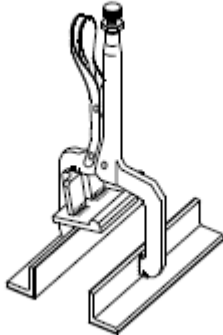

BUY-OUT

Part No. \_\_\_\_\_

ENDLAP CLAMP

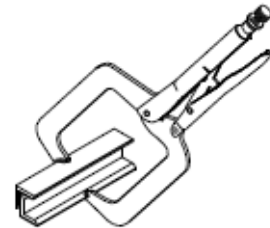

BUY-OUT

Part No. \_\_\_\_\_

MODULARITY TOOL



Part No. \_\_\_\_\_

Used to hold panel width modularity. (3) Supplied with each building order.



## 10.0 Roof Installation Preparation

### 10.1 General

The following details provide graphic illustration of the roof assembly steps. The purpose is to instruct the erector in correct and efficient assembly of the roof system.

Because of the many variations in conditions, it is important that you review the job to identify and isolate the specific installation details required for your job.

Review the erection drawings for differences with these details. If differences exist, the erection drawings have precedence.

These details are arranged in a step-by-step sequence. Following this sequence ensures correct assembly and ensures that the part to be worked on will be readily accessible for the next assembly step.

**DO NOT** shortcut these assembly steps without carefully consideration of the possibility of incorrect or omitted assembly and the resulting corrective rework.

To minimize confusion, the details are always oriented so that the view is from eave to ridge, with the starting rake at the left and finish rake at the right. Refer to the erection drawings to determine the required sheeting direction and rake conditions.

To help ensure weather tightness, the details emphasize proper fit-up, sealing and fastening. It is important that only the specified sealants and fasteners be used for each condition and that they be installed correctly as shown on the details and the erection drawings.

Be sure that these critical instructions are reviewed often and the roof assembly is checked at each assembly step.

### 10.2 Orientation and Explanation

The details in this section will show the installation of the eave plate, eave mastic, rake angle, rake support angle, and the first run of insulation. These are the parts that **must** be installed **before** the roof panel installation can begin.

The view on the next page shows the roof system oriented for a left-to-right sheeting direction. For right-to-left sheeting direction, reverse the parts orientation. The panel erection sequence **must always** be started from the low eave corner working toward the high eave or ridge. The full panel run from eave to high eave or ridge **must** be installed before the next panel run can be started.

In the case of a building with a roof step, the lower level panels **must** be installed before the upper level panels. Install six lower panels ahead of the upper panels.

### 10.3 Wall Rake Angle Attachment

Start the wall rake angle (SA1) flush with the edge of the eave member (long leg vertical) as shown below. Place the angle  $\frac{1}{4}$ " away from Steel Line and attach to each secondary support member with (1) RF1 fastener for purlins or (1) Tek 5 fastener for joists. Fastener placement not to exceed 1" from Steel Line.

The use of a string line or chalk line will insure that this angle is straight which assists in plumbing the gable ends of the wall panels with the girts. The straight line also assists with starting off straight with the rake support angle.

On this view, the starting and finish rakes are shown with rake support angles for both start and termination panel. Some buildings may require two rake support angles at the starting and/or finish rakes. Refer to the erection drawings for the required rake conditions.

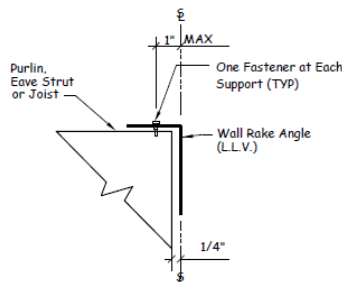
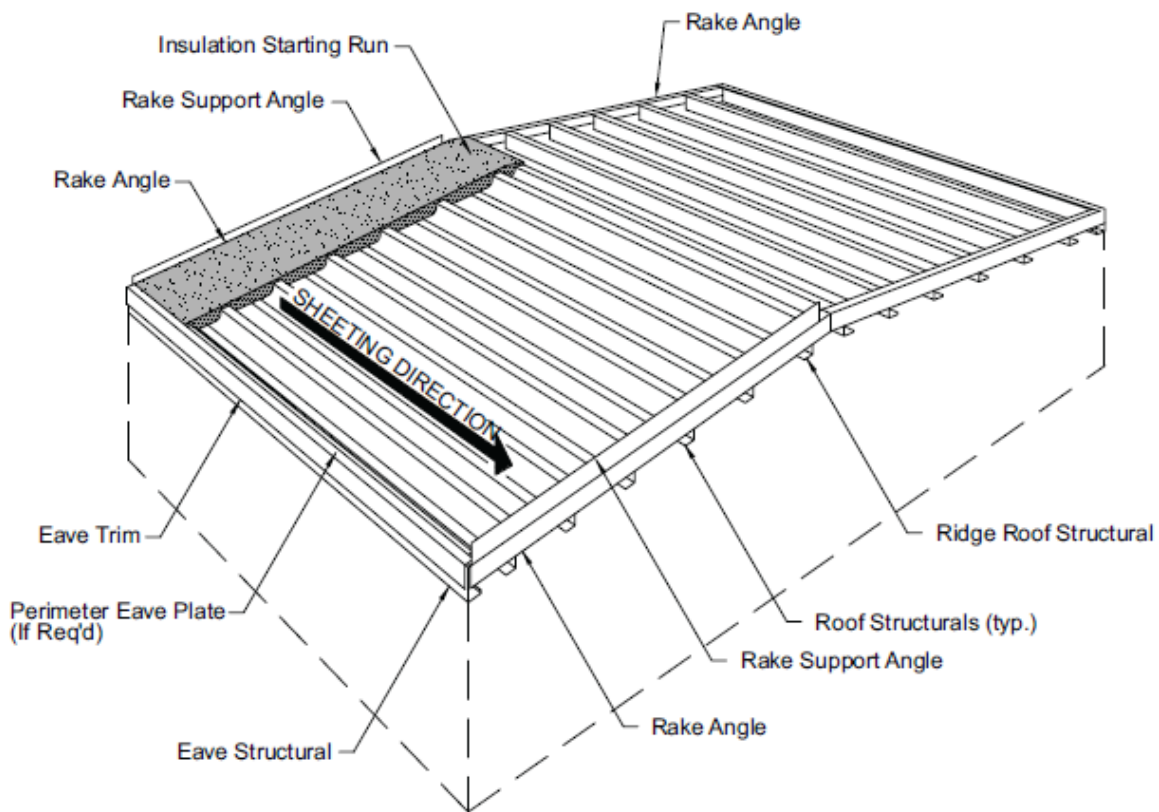

## 10.4 Eave Plate Attachment

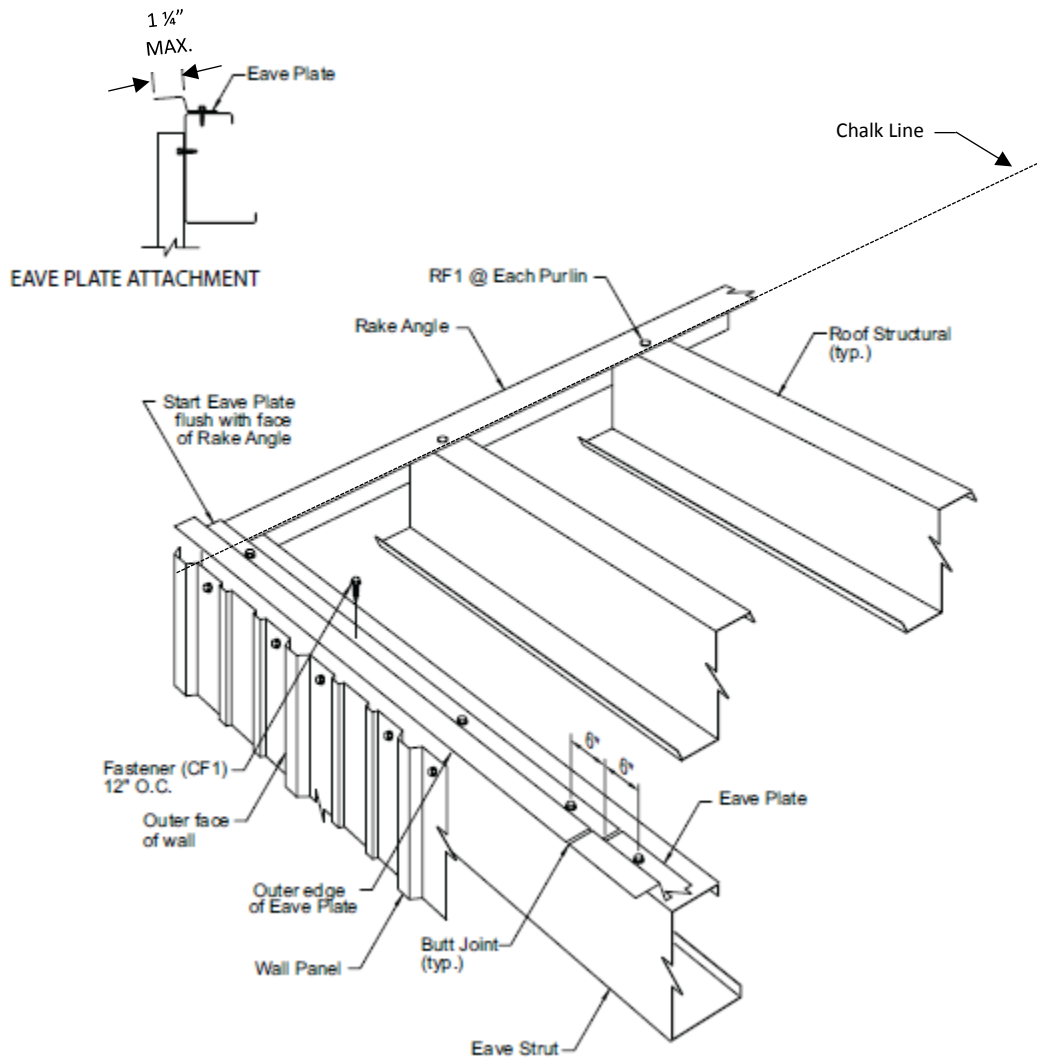

Refer to the erection drawings roof line trim details for the required eave plate part number.

The eave plate provides a solid attachment surface for the low eave end of the roof panel and the roof insulation.

The eave plate **must** be installed before the roof insulation is placed over the roof secondary members.

**Before installing the eave plate, check that the eave secondary members are in straight alignment from rake to rake and that the building is square.**

Install the starting and finishing ends of the eave plates flush with the outer face of the rake angle.

Place the eave plate at the edge of the eave secondary member. The top leg of the eave plate will extend past the low eave steel line (1 1/4" maximum) or flush with the outside face of the wall panel.

Fasten the eave plate with CF1 fasteners 12"- O.C. Tightly butt join the eave plate ends together.

See the erection drawings for sculptured eave trim installation instructions.

## 10.5 Rake Support Angle Installation

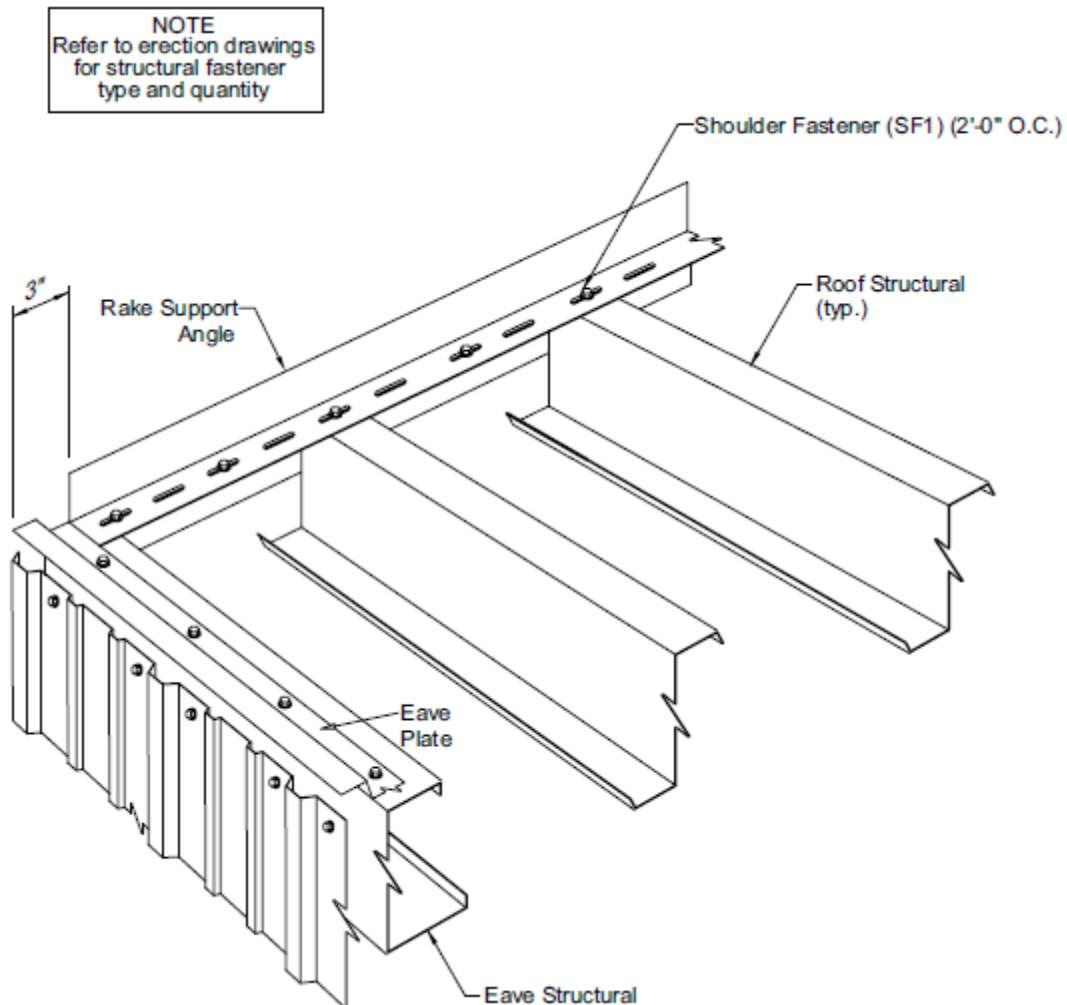

Refer to the erection drawing details for the required rake support angle part number. (RSA338 or RSA438 for example)

Refer to the erection drawings and the structural layout to determine the start dimension.

The position of the rake support angle establishes the starting roof panel alignment. It is very important that the angle is installed in a straight line, parallel to the rake line and rake angle.

See erection details for locations of all angles.

Start the rake support angle 3" from the sidewall steel line.

If the rake support angle is not true and square, a chalk line should be used to guide the installation.

Secure the starting end of the rake support angle to the rake angle with a SF1 fastener in the first slot.

Locate the shoulder fasteners (SF1) at the spacing shown. These fasteners **must** be located in the center of the pre-punched slot to allow for thermal movement.

### 10.5 Rake Support Angle Installation

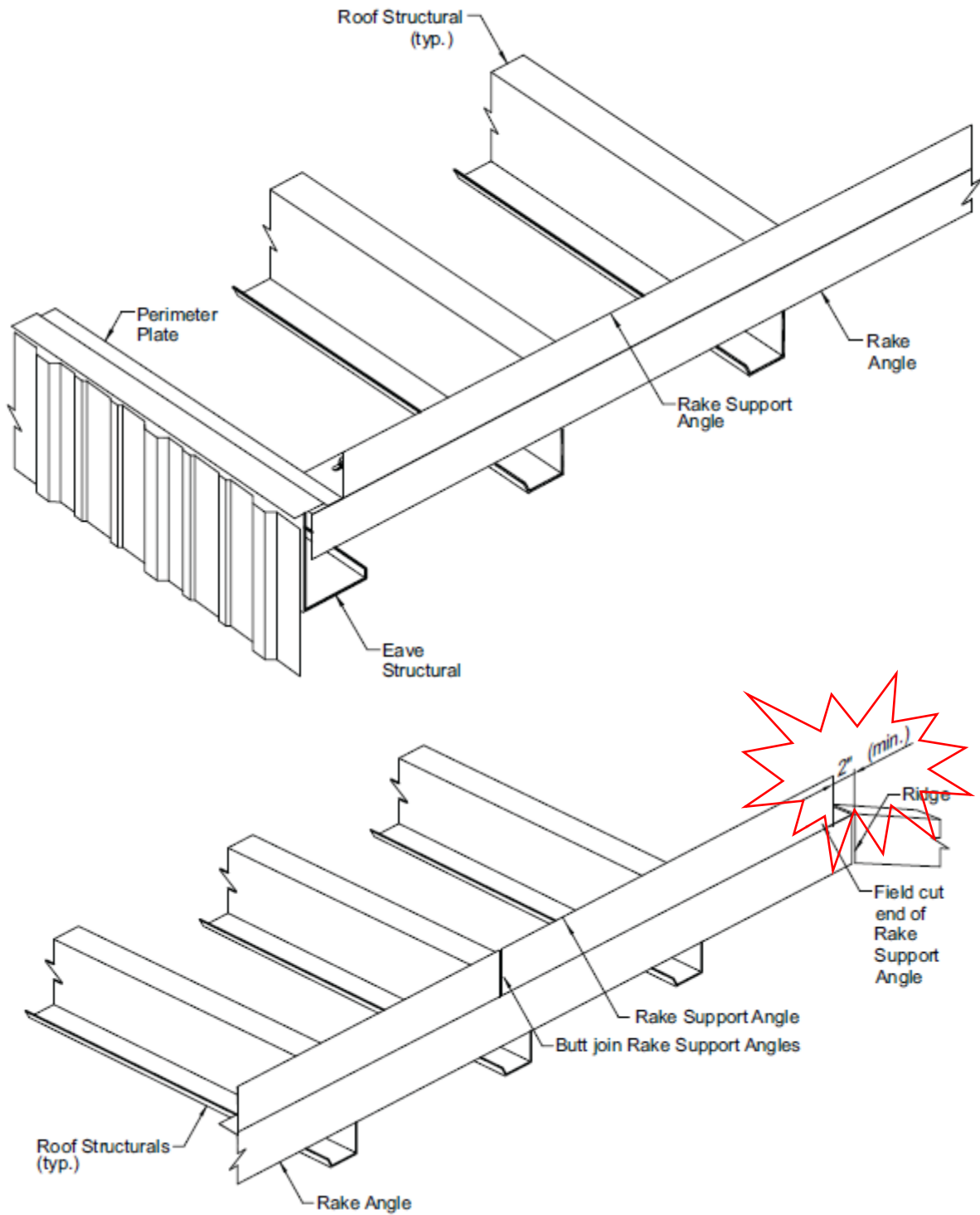

Butt join the ends of the rake support angle. Install shoulder fasteners (SF1) in the slots on either side of the butt joints.

Field cut the rake support angle two-inches (2") from the ridge line or high eave line for thermal expansion/contraction.

## 10.6 Eave Trim Installation

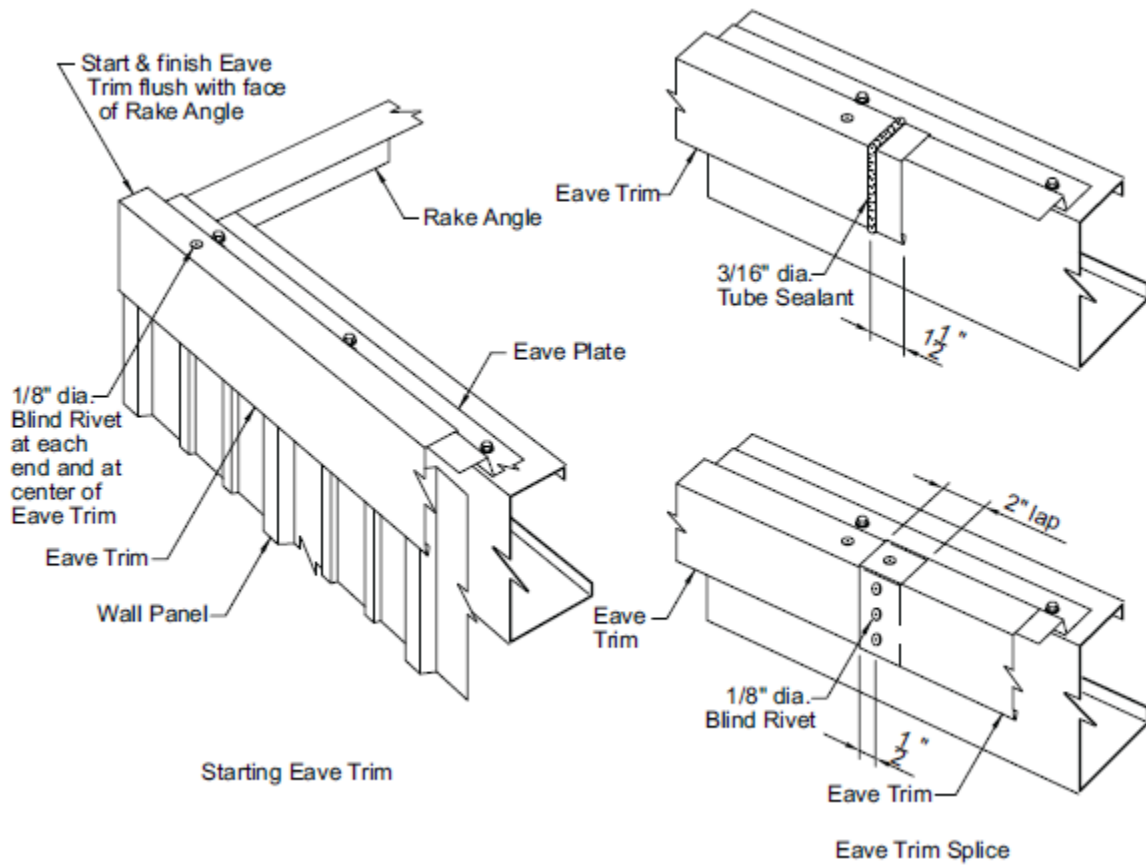

Place the upper horizontal lip of the eave trim over the eave plate as shown and align the vertical face of the eave trim with the face of the wall panel.

Install the start and finish ends of the eave trim flush with the ends of the eave plate.

The eave trim provides a water seal between the roof panel and the wall panels. All laps of the eave trim **must** be sealed with MS Polymer or Permathane tube sealant and rivets as shown to minimize water entry.

Fasten each piece of eave trim to the eave plate with three blind pop rivets. The rivets will hold the trim in position until the roof panels are installed and fastened.

## 10.7 Starter Run of Insulation Installation

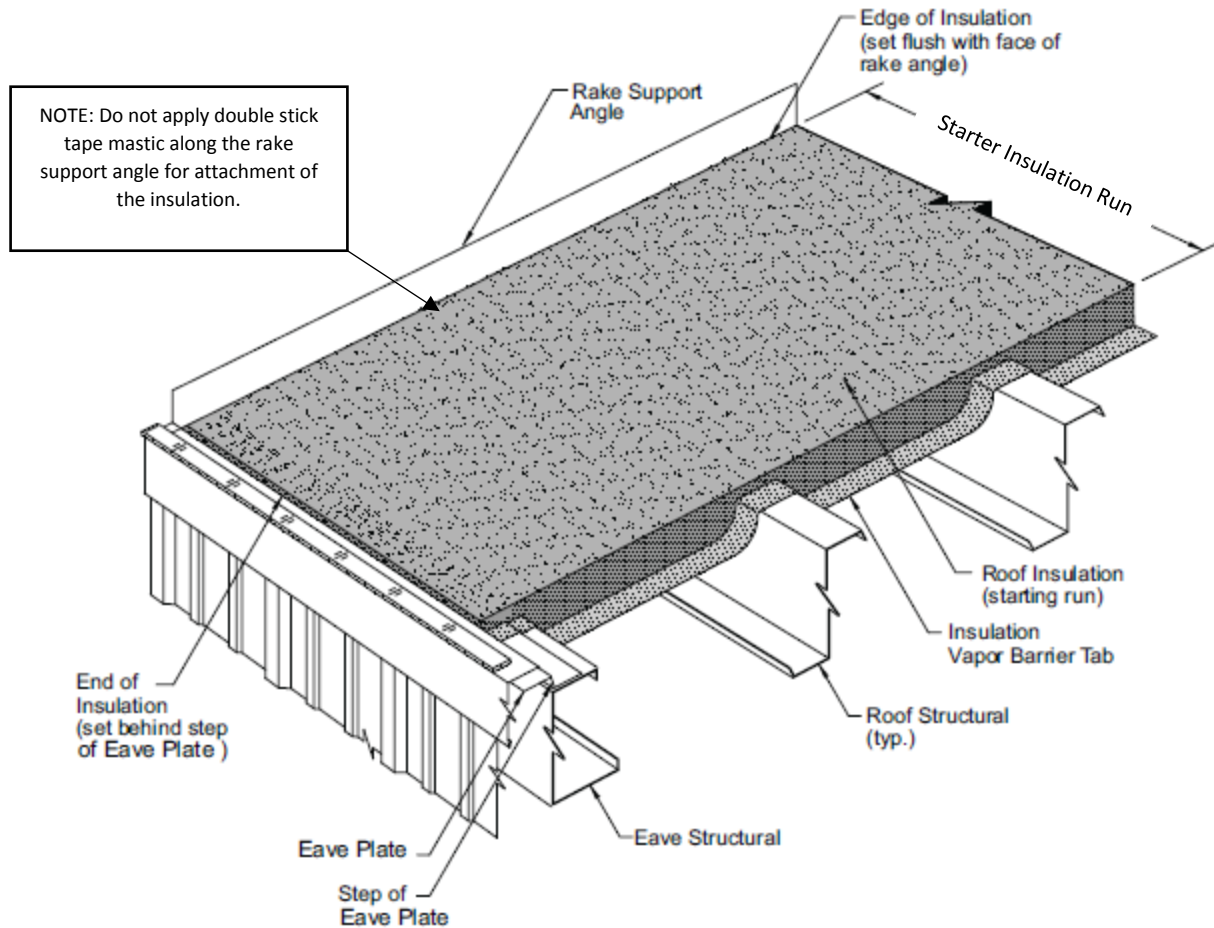

Install the insulation pan (optional – refer to the erection drawings or the insulation instructions to see if your project requires an insulation pan) at the ridge prior to any insulation installation.

Refer to the purchase order to determine the specific insulation required for the project. In all cases refer to the insulation manufacturer's instructions for proper insulation installation and vapor seal assembly. This detail shows fiberglass blanket insulation, which is the most commonly used insulation for metal standing seam roofs.

Use double-faced tape along the backside of the eave strut to hold the insulation in place while the roof panel is being installed.

**Do not** extend the end of the insulation onto the high of the eave plate.

Align the edge of the insulation with the building steel lines at both the rake and eave.

Pull the insulation toward the ridge/high eave so as to create a smooth appearance of the insulation backing.

Consult the insulation manufacturer for proper seaming and taping methods. At the high side/ridge, use fasteners (CF1) with insulation retainer washers placed 12-inches O.C.

At the low eave, remove a 4" strip of insulation from the backing leaving the strip of backing exposed. Fold this strip of backing over the insulation batt creating a double vapor barrier. (see details on next page)

Fasten the insulation to the backside of the eave strut over the double-faced tape using fasteners (CF1) and insulation retainer washers.

10.7 Starter Run of Insulation Installation

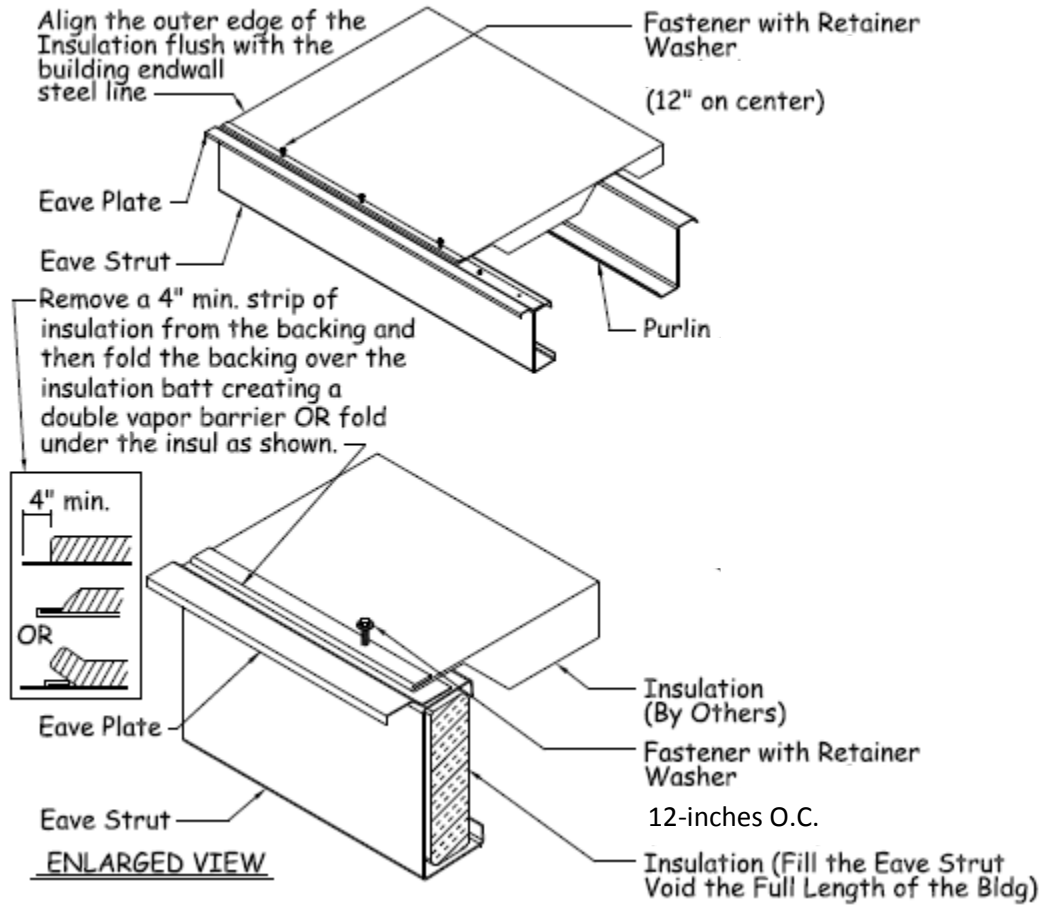



### 10.8 Thermal Blocks

Thermal blocks are used ONLY with tall panel clips.

Position the thermal block on top of the insulation over each purlin/joist line before installing the roof panels.

Place the thermal block tight against the rake angle and the next panel clip. Thereafter, the blocks will be placed between panel clips.

### 10.9 EPS Foam Spacer

EPS Foam Spacer is used ONLY with short panel clips on buildings **WITHOUT** insulation.

EPS Foam Spacer is provided in 50-foot rolls and is placed on top of the purlin leg before installing the panel clips.

EPS Foam Spacer has an adhesive backing. Remove the protective paper before rolling it out onto the purlin.

In the absence of insulation, the EPS Foam Spacer will reduce noise and vibration caused by the wind. It may also help reduce damage caused by metal to metal contact.

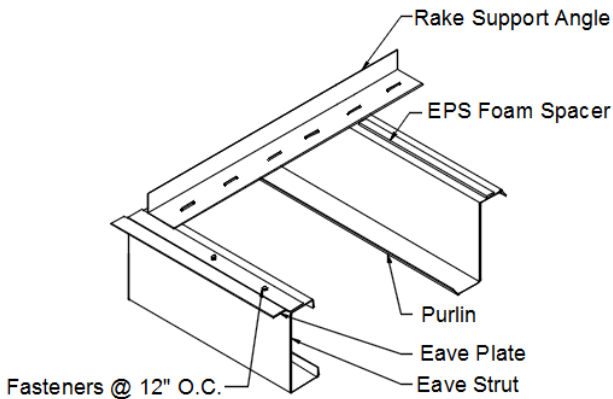

EPS FOAM  
SPACER DETAIL  
(IF REQUIRED)

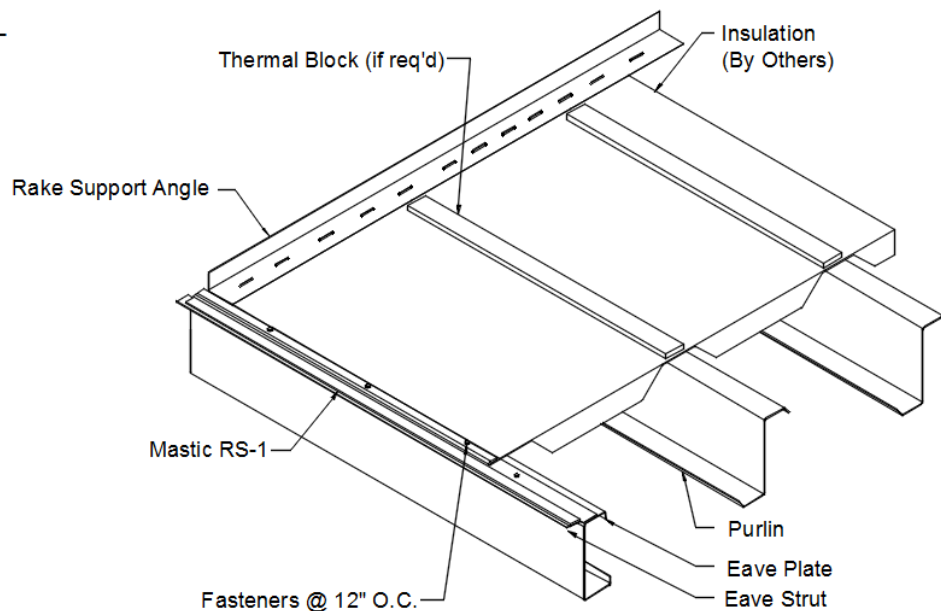

## 10.10 Proper Mastic Installation Procedures

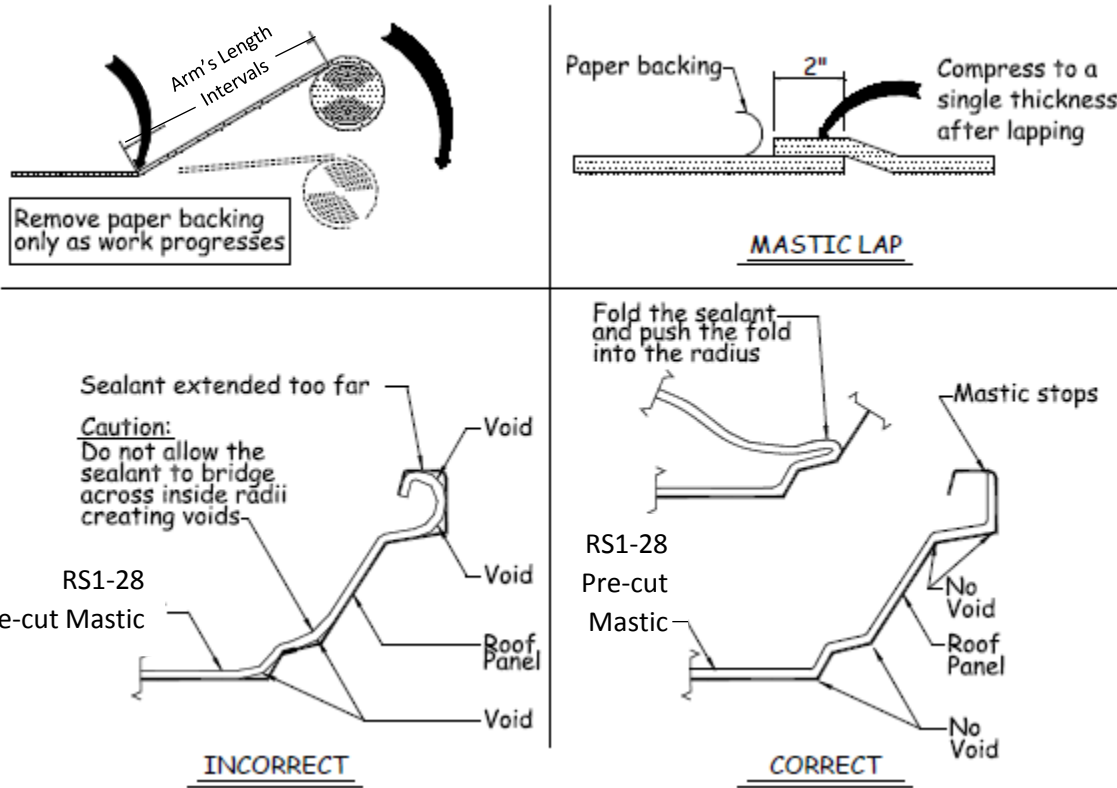

### Apply mastic only to clean, dry surfaces.

Roll mastic out in arm length intervals. Press the mastic firmly in place making sure it is tightly formed to all bends.

Remove paper backing **only** when ready to install the top component.

Splice mastic with a 2-inch lap. Press lapped pieces of mastic firmly together to form a single thickness.

**DO NOT STRETCH THE MASTIC ACROSS CORNERS. THIS WILL DECREASE THE THICKNESS WHERE IT IS NEEDED THE MOST, AND MAY NOT PERFORM AS DESIGNED.**

### 10.11 Eave Sealant Installation

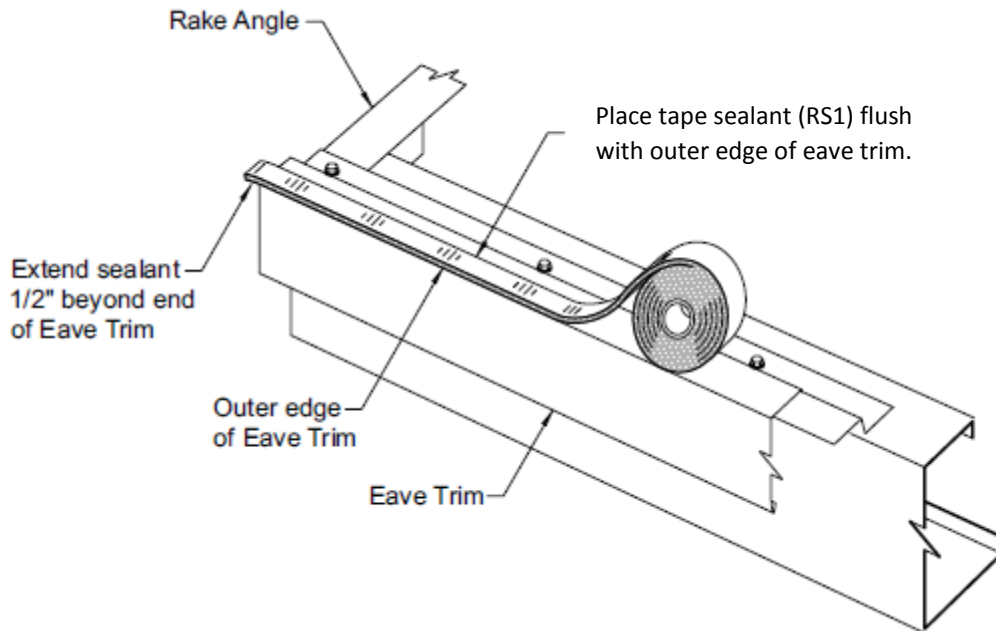

Apply a **continuous** strip of tape sealant (RS1) along the top edge of the eave trim.

Align the outer edge of the sealant flush with the outer edge of the eave trim.

**Do not** remove the paper backing from the sealant at this time.

Until the roof panels are installed, the eave sealant is vulnerable to damage from foot traffic or dragging material over the eave. **Do not** step on or otherwise damage the sealant.

### 10.12 Final Pre-Panel Installation Detail

Before installing any roof panels, refer to the erection drawing roof sheeting plan and roof details to see if there are any special requirements.

**Make sure** that the eave plate is fastened to the eave member at 12-inches O.C. with CF1 fasteners.

**11.0 Eave Start Panel Installation**

**11.1 Panel Section, Description and Nomenclature**

Throughout this manual the reference to the panel will be made using the terms in the illustration below.

The Horizon TS-324™ Roof panel is designed so it can be installed in either direction (left-to-right) or (right-to-left). Check the erection drawings and job conditions to determine if the roof must be installed in a specific direction.

The leading edge of the roof panel is the edge toward the installation direction. On the Horizon TS-324™ Roof panel, the male seam is always the leading edge.

**Before loading the panels onto the roof secondary members, orient the panels so that the male seam is the leading edge.**

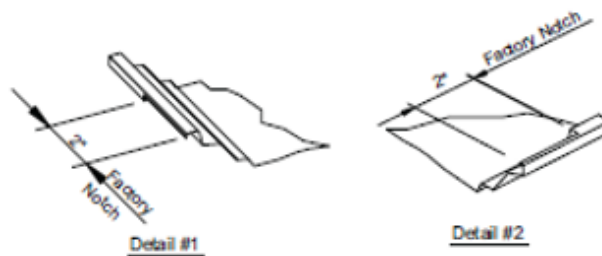
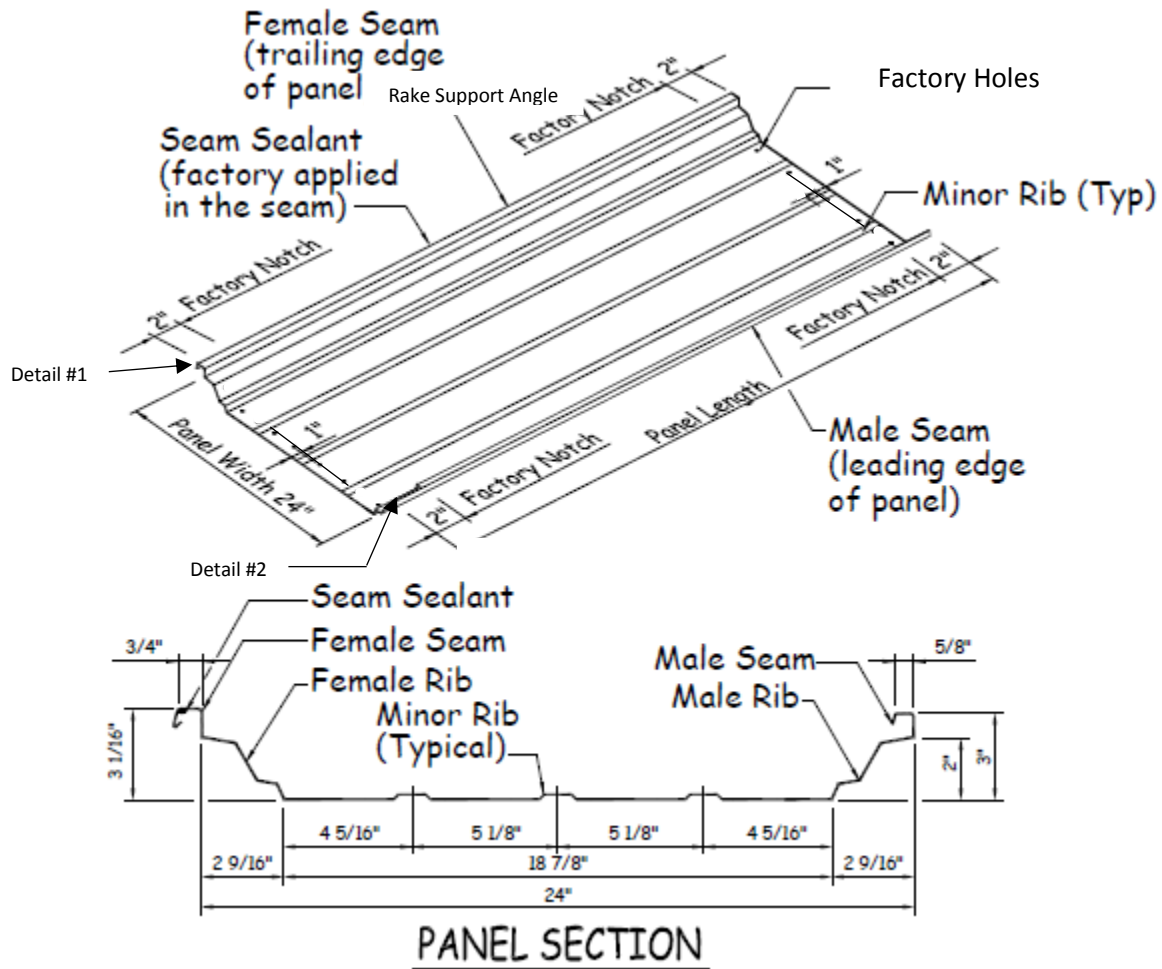

### 11.2 Orientation View

The details in this section show the installation of the starting and intermediate roof panels.

The roof panel end lap details are shown as an integral part of the roof panel installation. If the project does not require roof panel end laps, the end lap details are clearly identified and can be disregarded.

The termination roof panels require specific installation and are shown in a later section.

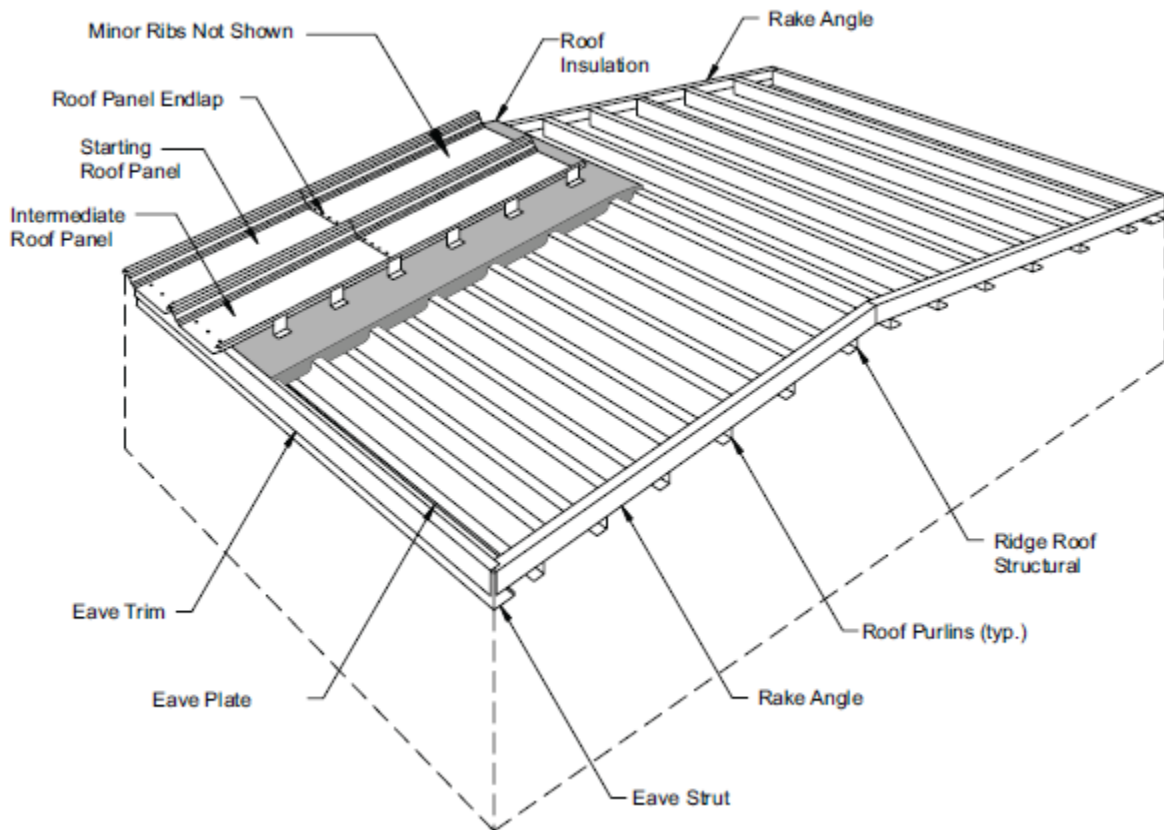

### 11.3 Installing the Low Eave Void Closure

Prepare the void closures by applying pre-cut 8-inch long tape mastic (RS8) along the top surfaces as shown in the illustration. Remove the protective paper. Note that the mastic extends approximately ¼" to ½" beyond the edge of the closure to blend into the RS1 eave mastic.

Peel back the protective paper from the eave mastic (RS1) as shown to clear the void closure.

Void closures are spaced at 2'-0" increments.

Check that the closure is centered to the roof panel's edge and will fully engage into the panel's trapezoidal rib when the panel is installed.

Fasten the closure to the eave plate with (2) clip fasteners (CF1) installed through the holes in the base of the void closure.

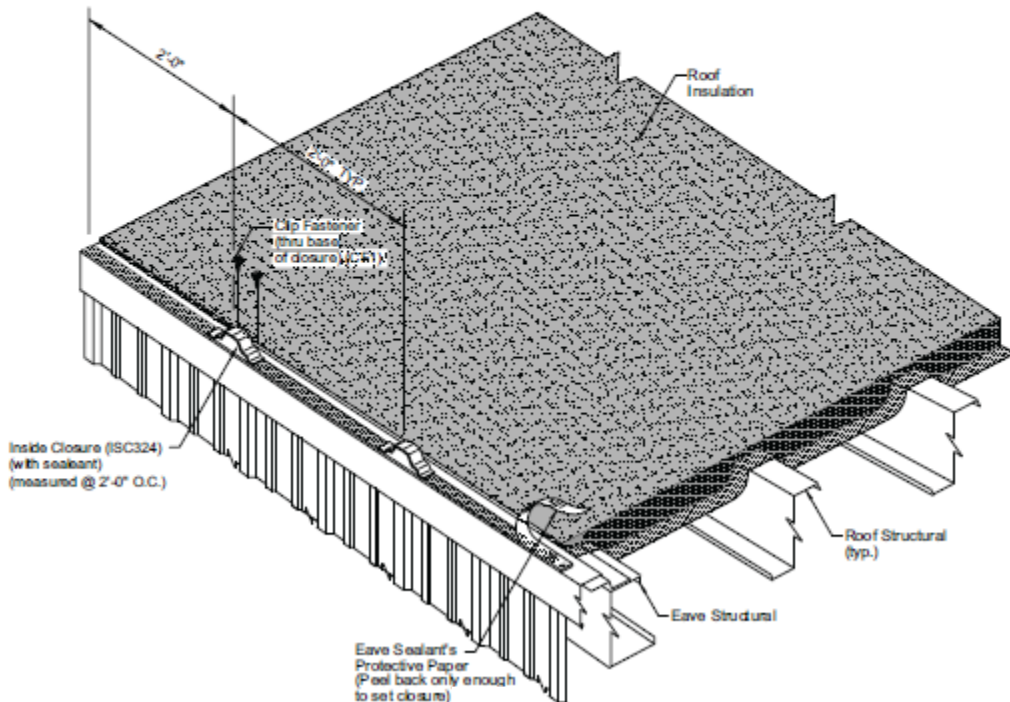
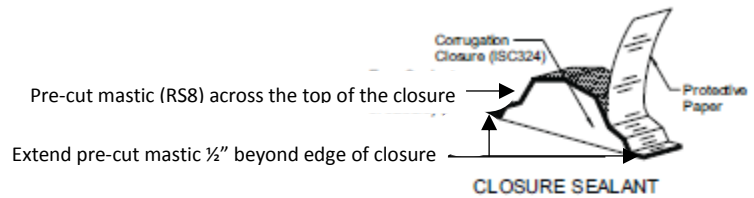
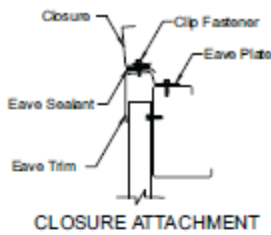

**NOTE: ANY PROTECTIVE COATINGS OR COVERINGS (PRIMARYLY ALONG THE PANEL'S TRAPEZODAL RIB ON PAINTED PANELS) MUST BE REMOVED BEFORE ANY PANEL CAN BE INSTALLED.**

### 11.4 Installing the Eave Start Panel

The roof panel's eave overhang dimension is critical as it establishes the location of end laps and the ridge cover attachment points.

**The end of the roof panel extends 3 1/2" beyond the web of the eave strut unless another dimension is specified on the erection drawings. Check the low eave detail on the erection drawings before installing any roof panels.**

If insulation thermal blocks are required, place the blocks on top of the insulation directly over the roof structural. **Thermal blocks are not required at the eave structural.**

Position the female edge of the panel over the rake support angle and position the end of the panel 3 1/2" beyond the web of the eave strut.

Tilt the panel as shown so the female seam can be hooked over the rake support angle.

Only remove the eave sealant's protective paper enough to set first panel.

**NOTE: Once the panel has contacted the mastic, it cannot be moved.** Be sure the start panel is properly positioned before seating.

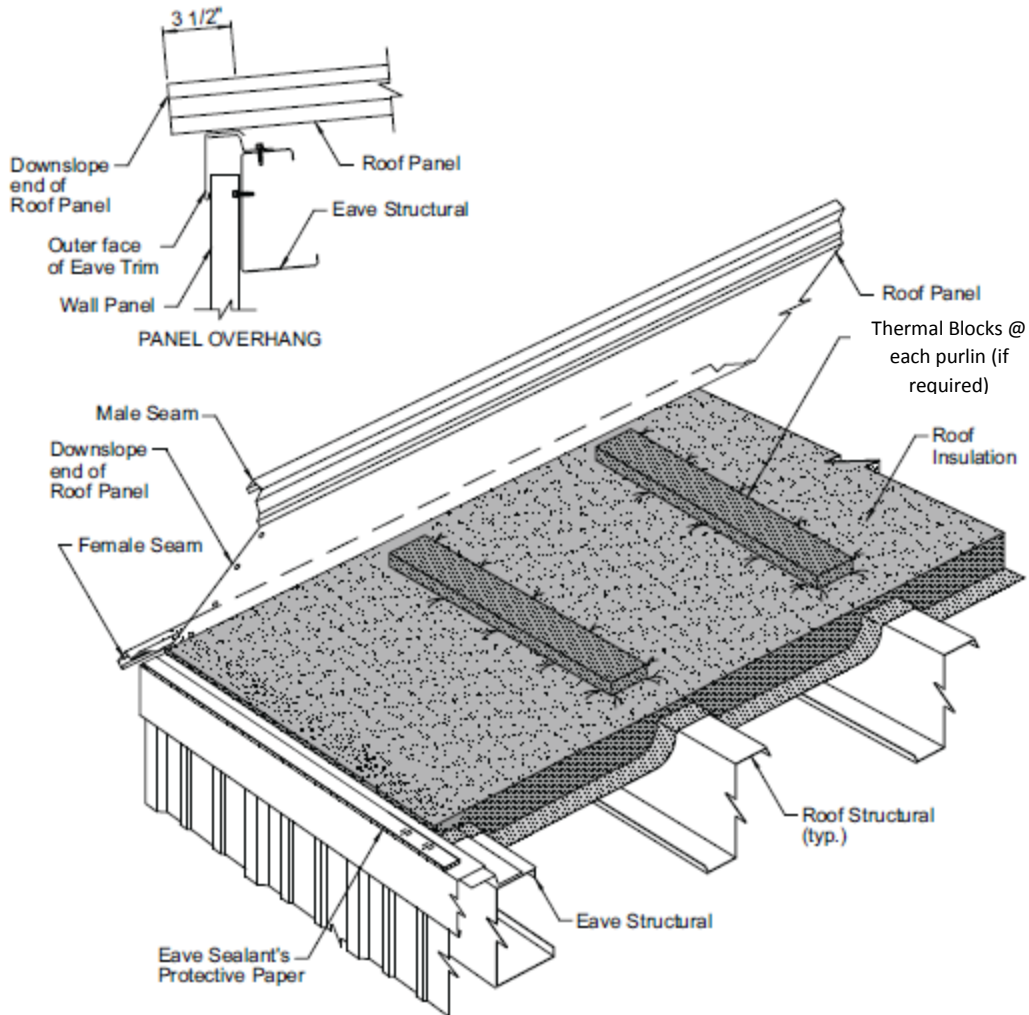

**NOTE: ANY PROTECTIVE COATINGS OR COVERINGS (PRIMARILY ALONG THE PANEL'S TRAPEZODAL RIB ON PAINTED PANELS) MUST BE REMOVED BEFORE ANY PANEL CAN BE INSTALLED.**

## 11.5 Installing the Leading Edge Panel Clips

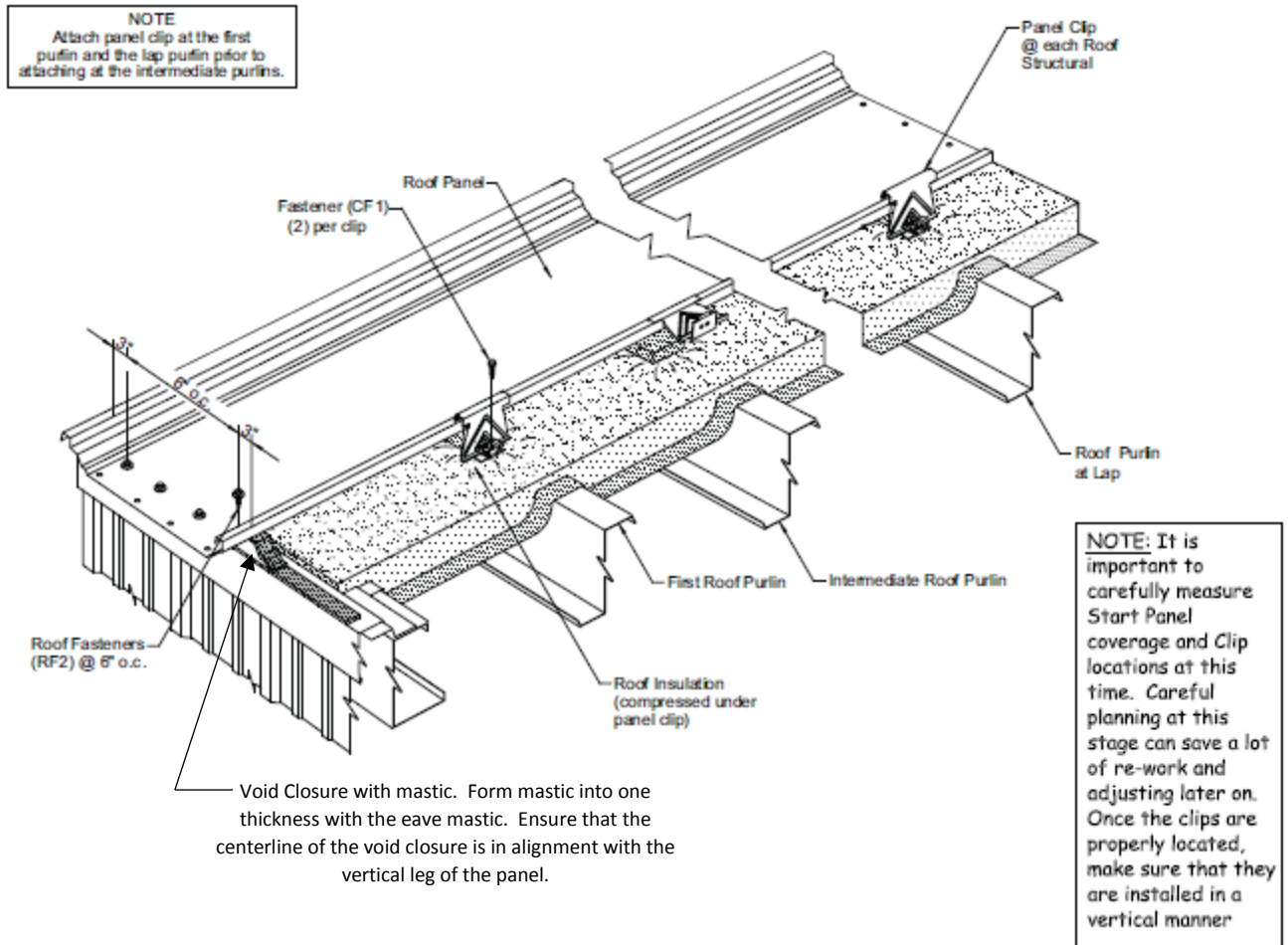

Before fastening the roof panel to the eave plate and fastening the leading edge of the panel with the panel clips, check that the panel coverage is correct and the leading edge of the panel is straight and parallel to the rake line.

Fasten the eave end of the panel with (4) roof fasteners (RF2) spaced 6-inches O.C. as shown (or in alignment with the pre-punched holes).

Position the fasteners (RF2) to penetrate through the center of the sealant, through the eave trim and into the eave plate.

Install the roof clips to the leading edge of the roof panel at each roof structural. **Panel clips are not required at the eave structural. Panel clips are not required at purlin strut locations.**

To install the panel clips, tilt the clip so that its tab can be hooked over the edge of the roof panel's male seam. Position the clips base so that the clip fasteners can be installed through the holes in the base and into the roof structural, then rotate the clip down into the vertical position.

When fiberglass roof insulation is used, the panel clips normally set on top of the insulation and the insulation is compressed between the clip's base and the top of the roof structural. In all cases, refer to the purchase order to determine the required insulation assembly and the relationship of the panel clips to the insulation.

Specific panel clip details are shown on the following page.



## 11.6 Typical Panel Clip Attachment Details

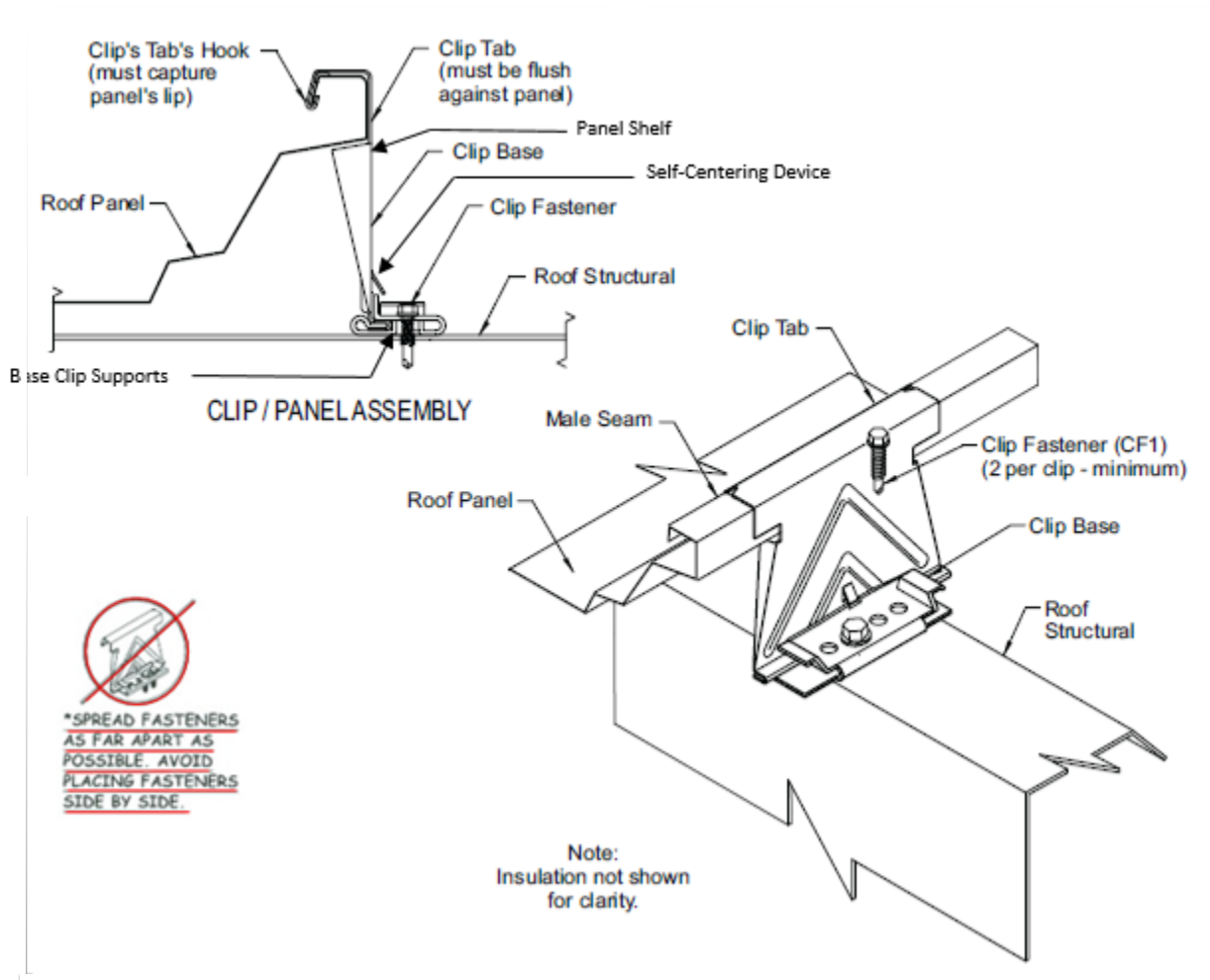

Panel clips are available as floating clips or fixed clips and are available in different stand-off heights. Refer to the erection drawings to determine the type of clip required for each roof condition.

Check that the panel clip's tab or hook is seated tightly around the roof panel's seam and that the panel clip's hook has captured the panel's male leg.

Check that the clip's base is vertical and that the base is set square and firmly over the roof structural.

Panel clip fastener type and quantity vary according to the roof structural material and roof load requirements. Refer to the erection drawings for the required type and quantity of panel clip fasteners.

Check that the clip fasteners are spread apart as far as possible. Avoid placing fasteners side by side.

Check that fasteners are installed through the clip base holes and securely engaged into the roof structural.

**NOTE: It is extremely important on floating clips that the self-centering device is disengaged to allow for thermal movement.**

**During the installation of the fasteners, insure that the clip base is compressed against the top of the base clip supports. This will then dis-engage the self-centering device.**

**Roof panel clips are not required at the eave or attaching to strut purlins.**

## 11.6 Typical Panel Clip Attachment Details

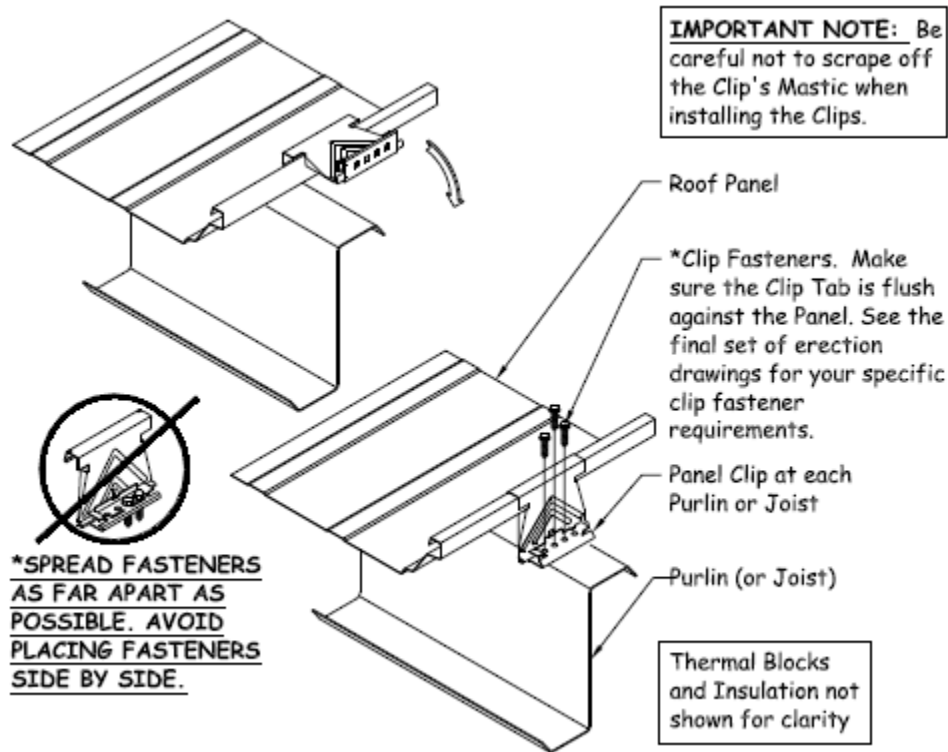

SBS' standard clip fasteners are designed to fasten to a steel structural member of .060" minimum thickness (16 Ga.). A minimum of **two fasteners** are required to engage into the structural member at **every** panel clip location.

Required fastener pullout values are dependent upon project location, size, building code, and loading. Consult Horizon Engineering for project dependent fastener specifications.

**CAUTION: DO NOT SCRAPE OFF THE CLIP'S MASTIC WHEN ASSEMBLING THE ROOF PANEL. If scraped off, replace with a 1/8-inch bead of non-skinning Butyl sealant.**

Do not over-drive screws. Over-driving can strip the threads. Use a screw gun with torque control set to function properly for the combination of fastener size, hole size and material thickness. **DO NOT use an impact driver.**

### 11.7 Installation of the Backup Plate at the Eave Start Panel

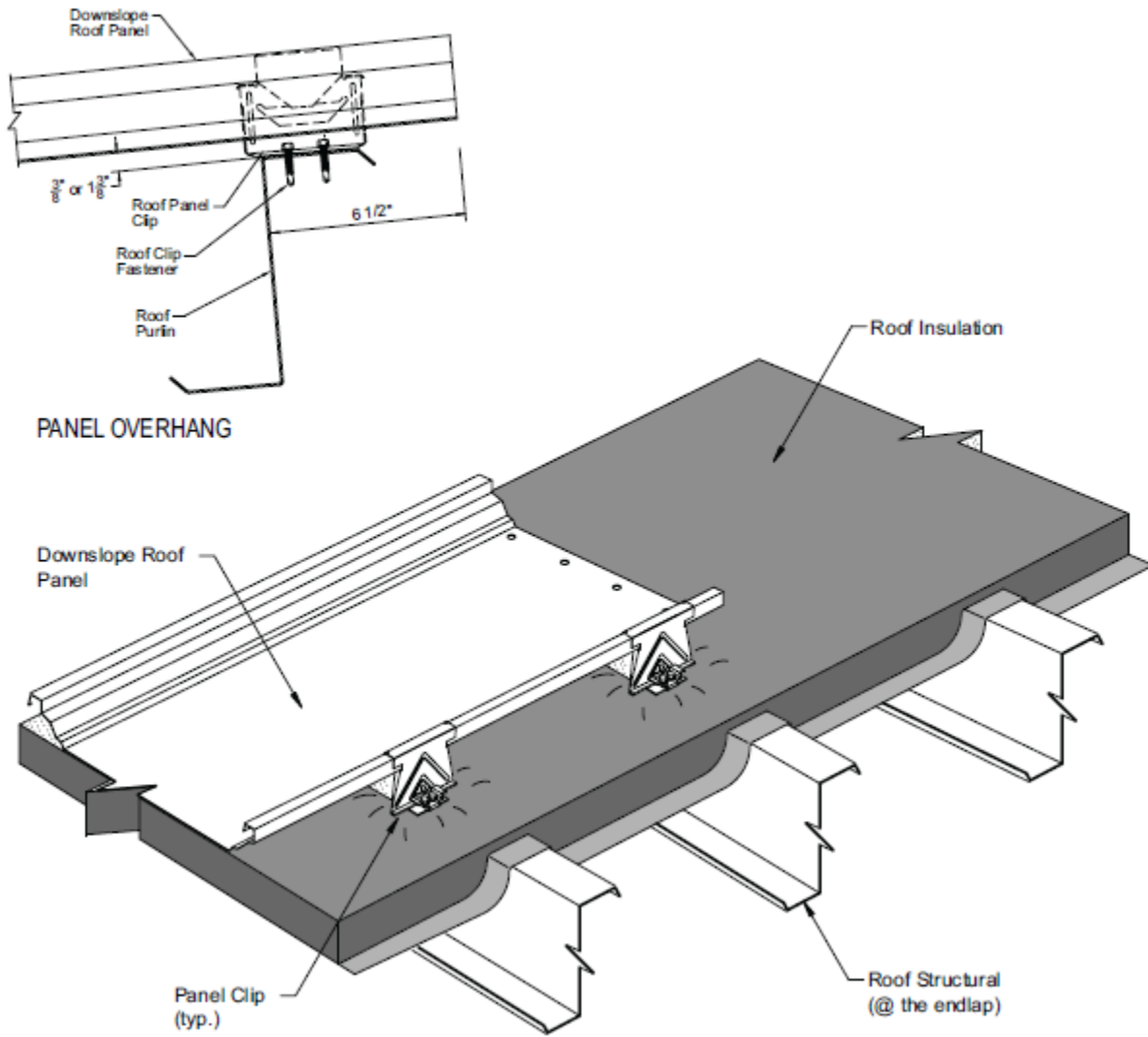

With the eave end of the roof panel attached, measure the panel overhang at the purlin (see illustration).

The panel should extend 6 ½” beyond the web of the purlin or joist.

If the panel overhang is not within this range, call Horizon Building Systems before proceeding with the installation of the roof panels.

### 11.7 Installation of the Backup Plate at the Eave Start Panel

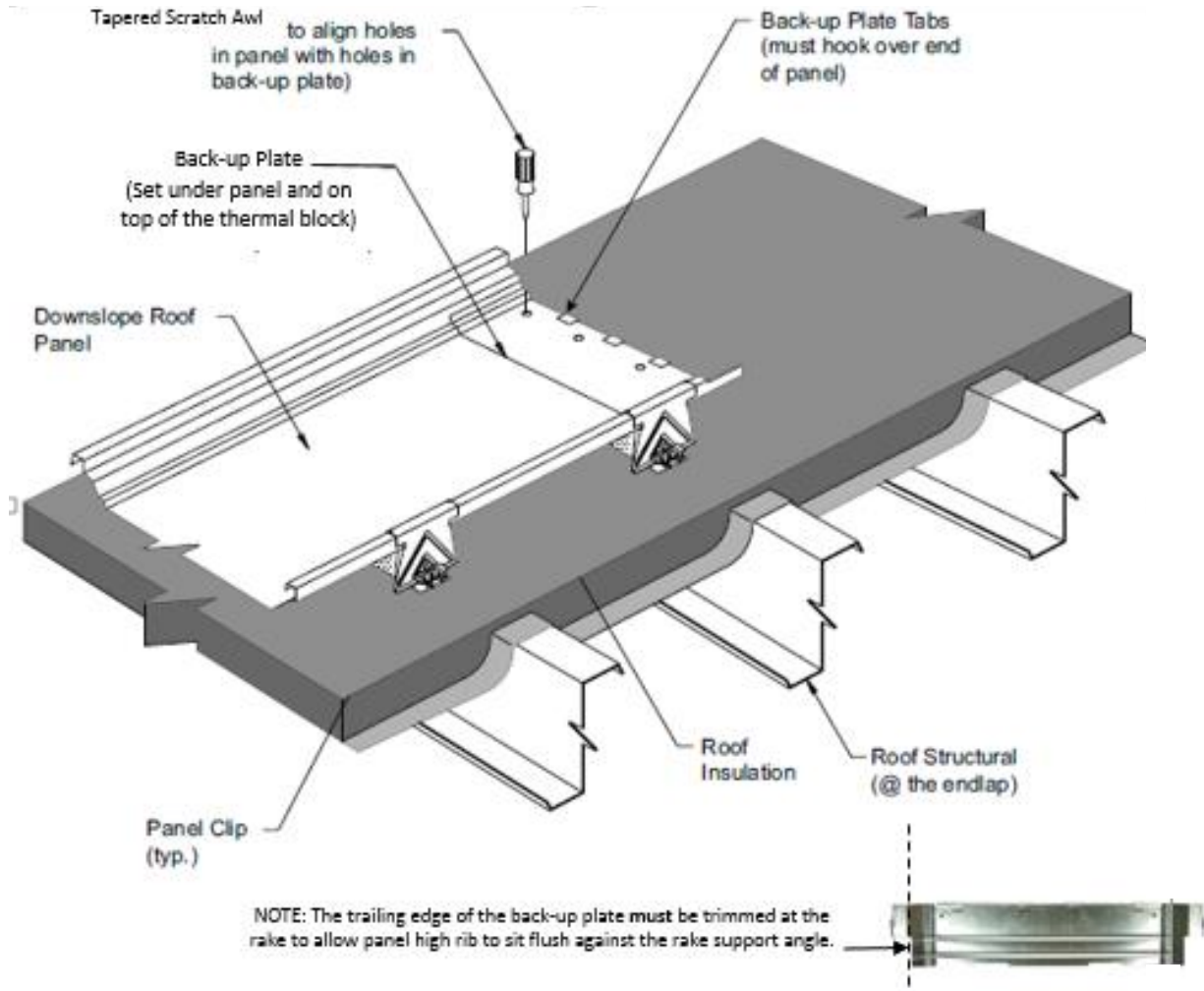

With tall clips and thermal blocks, verify the back-up plate is on top of the thermal block and block is located directly over secondary member.

Slide the back-up plate under the roof panel, as shown.

The back-up plate **must** be set over the top of the roof structural. If insulation thermal blocks are used, the back-up plate **must** be set over the thermal block.

The back-up plate's tabs **must** hook over the edge of the roof panel.

Use tapered scratch awls (not drift pins) to align the holes in the back-up plate with the factor punched holes in the roof panel.

## 12.0 Intermediate Start Panel Installation

### 12.1 Installation of the Intermediate Start Panel Mastic

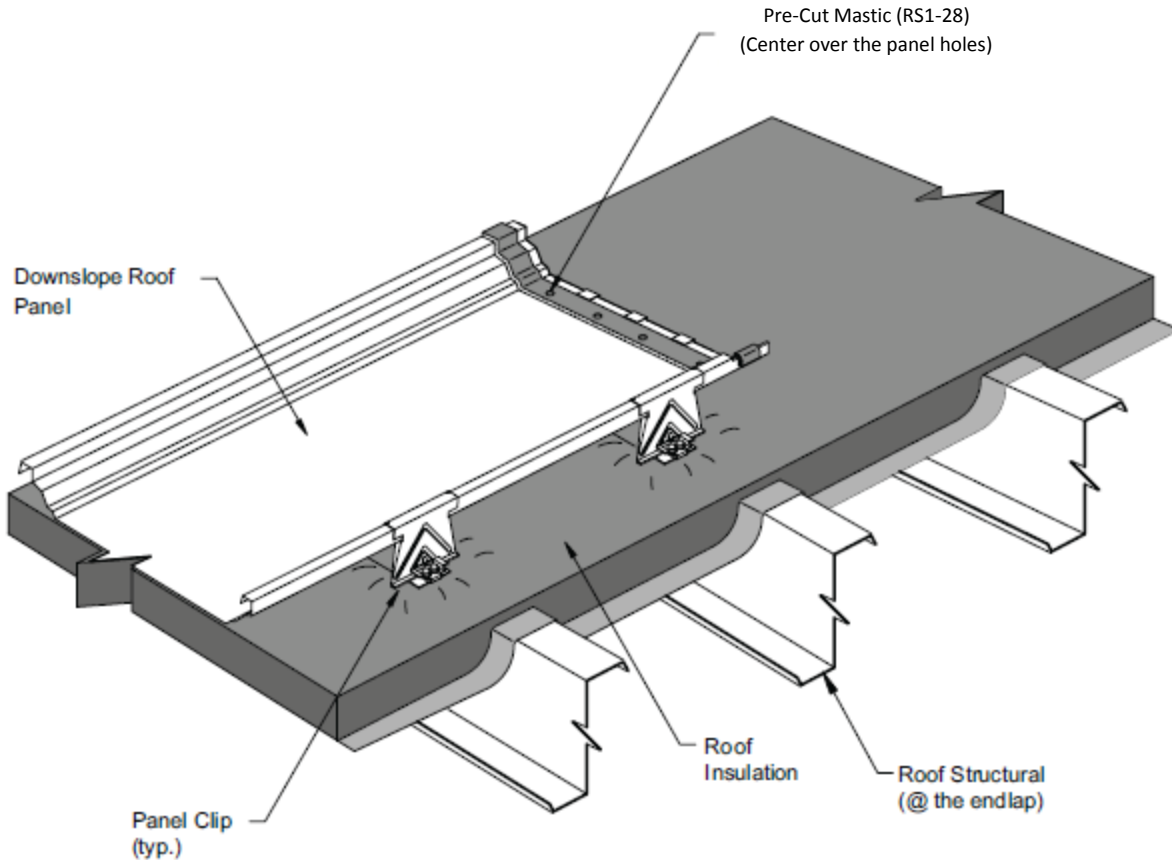

The proper placing of the end lap mastic is critical to the weather tightness of the roof end laps.

Before installing the end lap mastic, the roof panel's surface **must** be wiped clean and dry.

Position the sealant so that it is centered over the roof panel's pre-punched holes. The up-slope edge of the tape mastic should be roughly 3/16" down-slope of the roof panel edge.

Apply the 28" pre-cut tape mastic (RS1-28) starting at the top edge of the notched edge of the panel.

The tape mastic should end up over the top horizontal leg of the female rib.

Check that the sealant contacts the roof panel's surface and that it is completely fitted into the panel corners and around the seams.

The sealant's protective paper helps to retain the sealant's shape during installation and protects the sealant's surface from damage and contamination. **Do Not** remove the protective paper until immediately before the installation of the up-slope roof panel.

Next apply a bead of Butyl standing seam construction sealant in the rib areas of the panel (at both the male and female ribs). The caulk should be adjacent to and up-slope from the tape mastic.

Specific end lap sealant details are shown on the following page.

12.2 Installation of the Intermediate Start Panel Butyl Caulk

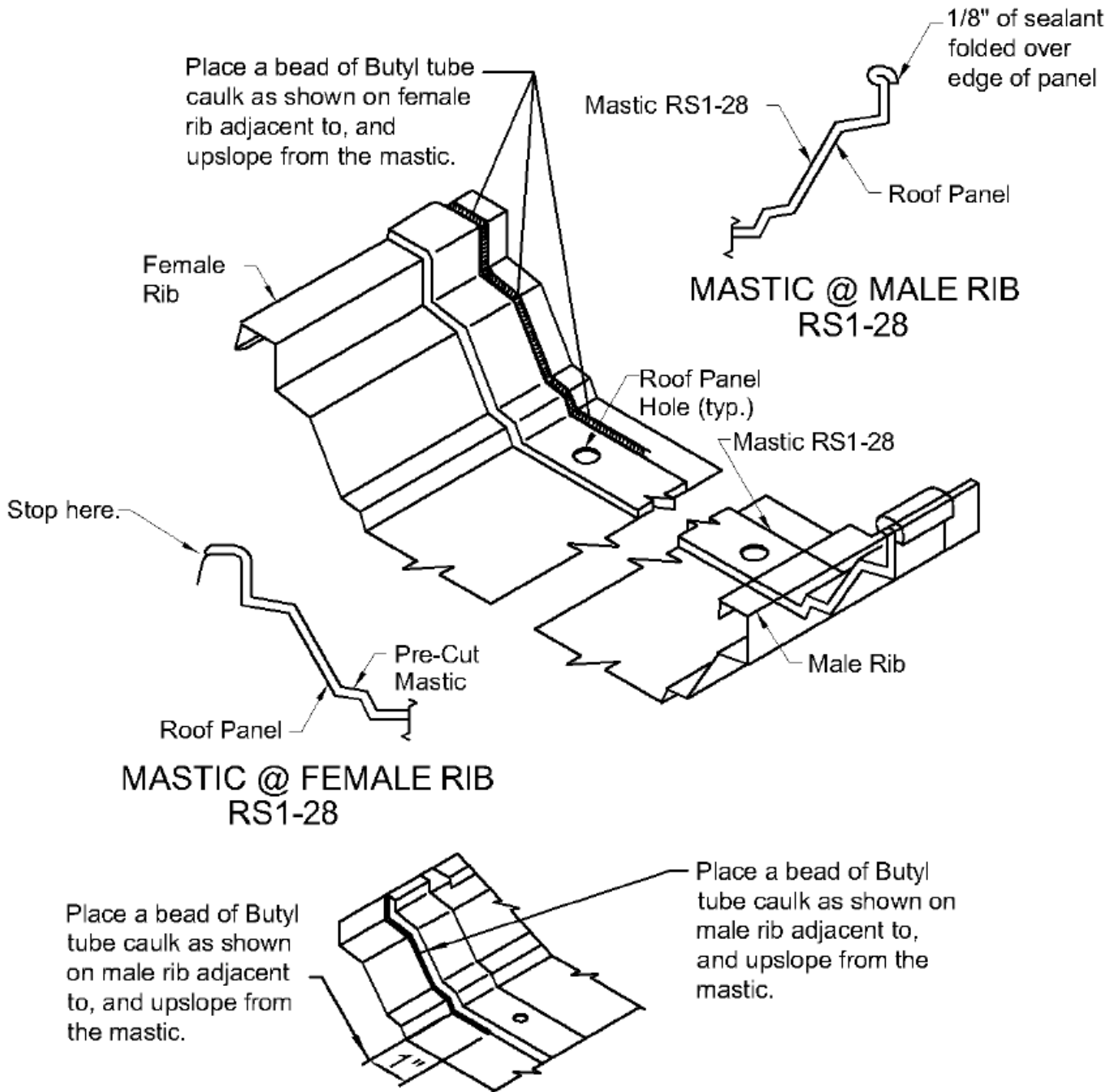

### 12.3 Alignment of the Intermediate Start Panel

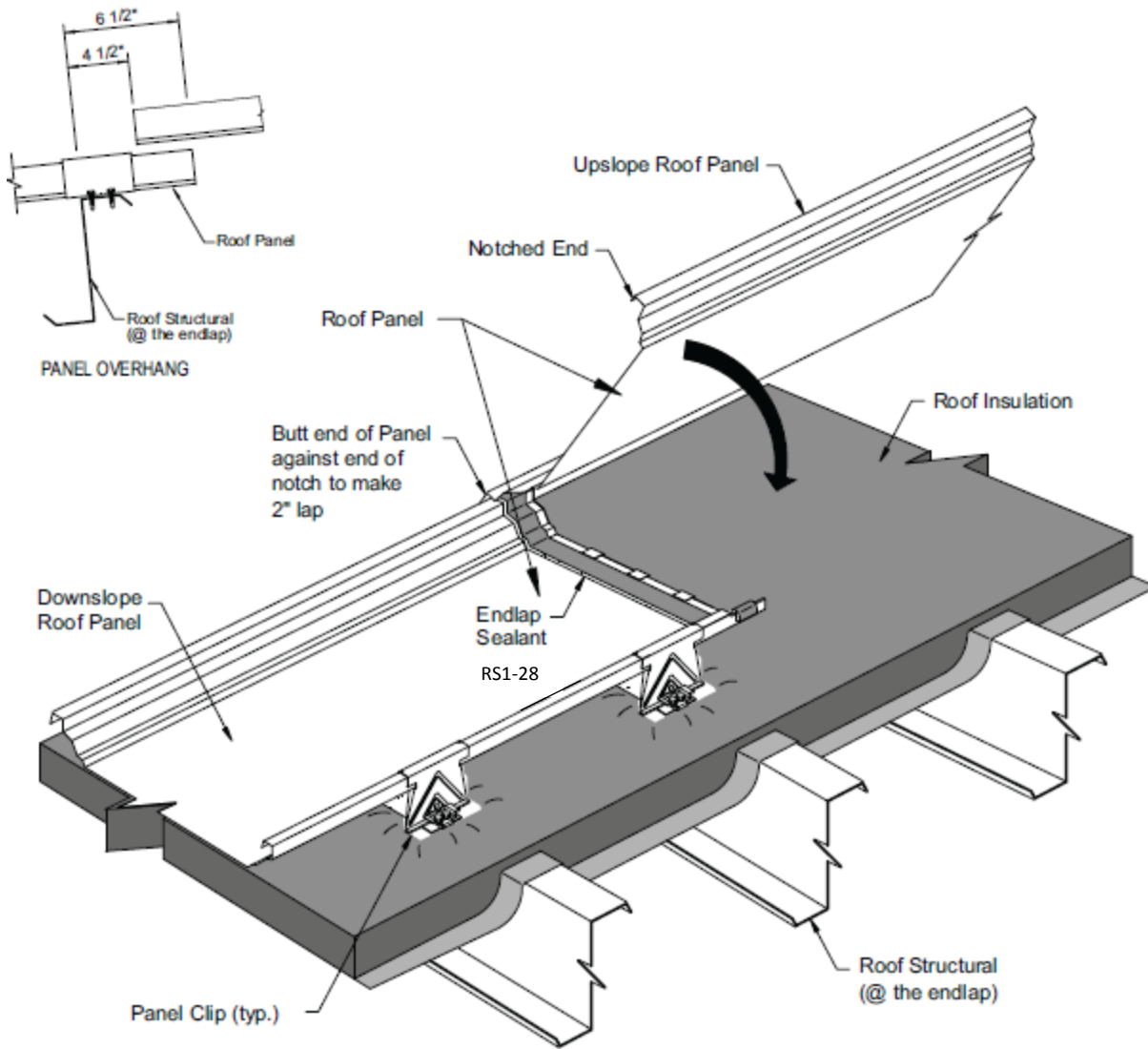

After all tape mastic and caulk is in place, wipe dry and clean the underside surface of the up-slope roof panel.

Remove the protective paper from the installed end lap mastic.

Position the end of the up-slope roof panel to make a 2" lap over the down-slope roof panel.

At the seams, the end of the up-slope roof panel should butt against the notch on the down-slope roof panel.

Check that the up-slope roof panel will correctly lap over the end lap mastic.

### 12.3 Alignment of the Intermediate Start Panel

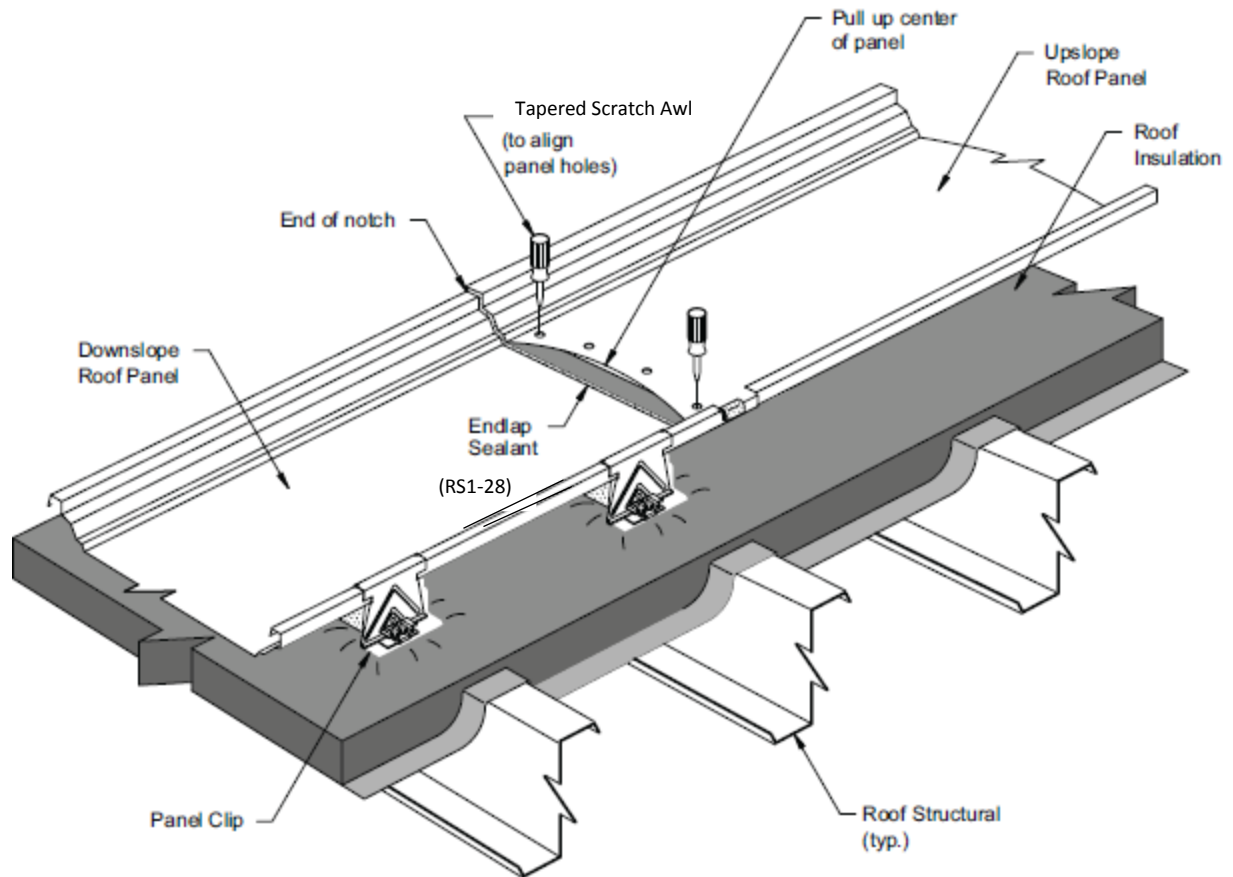

Lower the up-slope panel to lap onto the down-slope roof panel.

While lowering the up-slope roof panel, bow the end of the panel by pulling up on its center. This will allow the panel to more easily nest into the down-slope panel.

Use tapered scratch awls, **not drift pins, punches or Philips screw drivers**, to align the factory punched holes of the lapping panel. The scratch awl will also have to penetrate through the end lap mastic and into the holes in the back-up plate.

**Do not** disturb the position of the mastic while inserting and removing the scratch awl.

**Do not** remove the scratch awls from the roof panel holes until after the seam clamps have been installed.



## 12.4 Fastening the Intermediate Start Panel

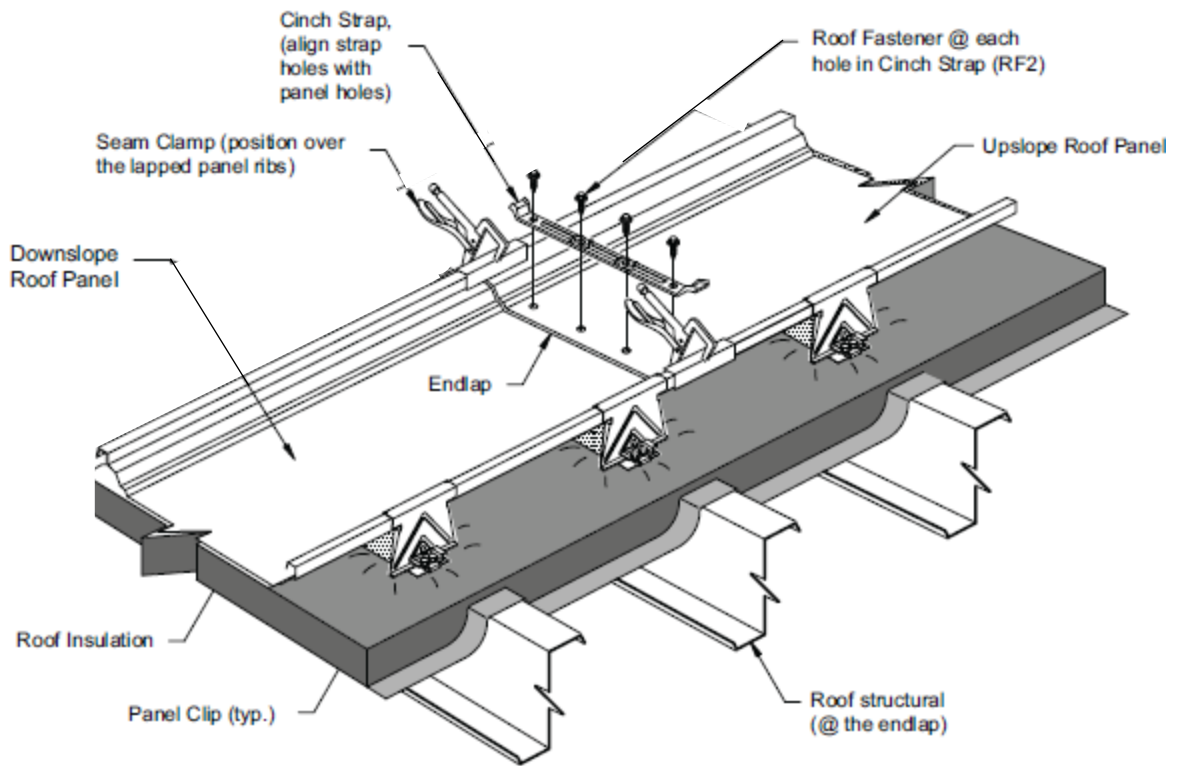

A cinch strap is **required** on all roof end lap applications.

Carefully remove the tapered scratch awls and position the cinch strap over the factory punched holes in the roof panel.

Use the tapered scratch awls to now align the factory punched holes in the cinch strap, both roof panels, tape mastic and the back-up plate.

Install roof fasteners (RF2) in the open holes. Carefully remove the tapered scratch awls and install fasteners in the remaining holes.

Check that the roof fasteners penetrate thru the center of the end lap mastic and are securely engaged into the back-up plate. A properly installed end lap profile will represent a straight plane. Any sagging appearance is unacceptable and the end lap will require to be reviewed and possibly re-worked.

Remove the seam clamps to complete the installation.

## 12.4 Fastening the Intermediate Start Panel

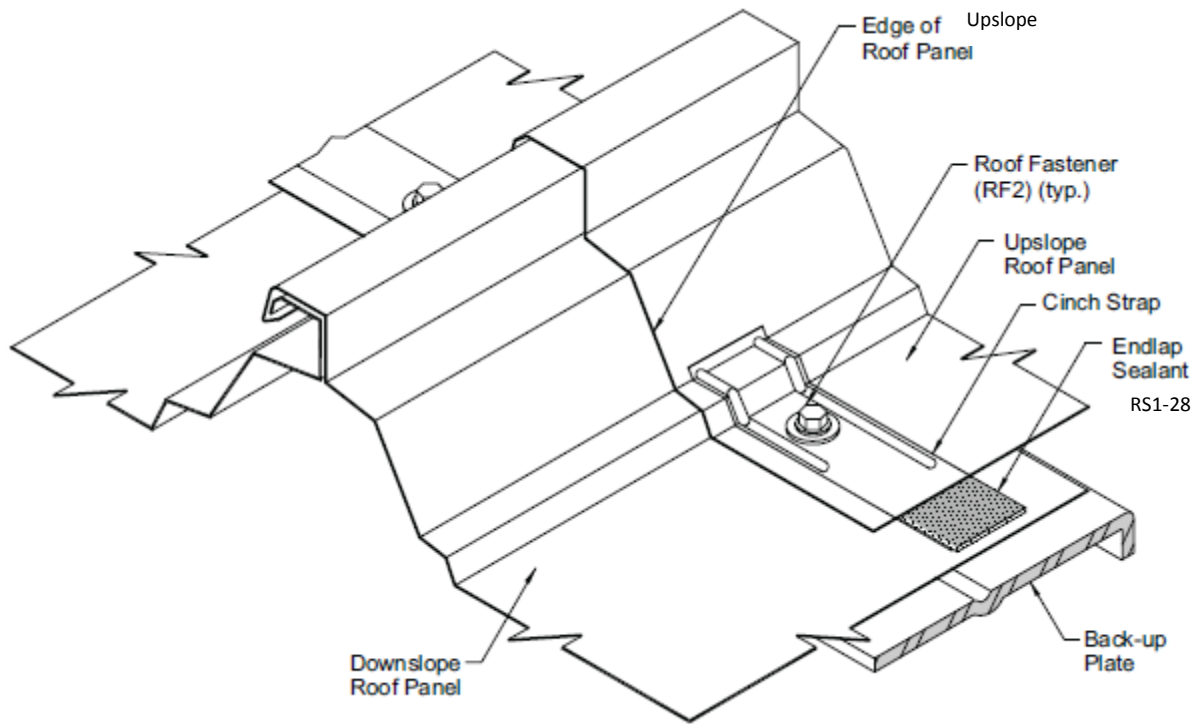

Check that the end lap is correctly assembled and that there are no gaps or voids of any kind between the lapped panels, especially at the critical corner areas.

If there is a void or gap, make appropriate corrects at this time before proceeding.

### 13.0 Full Panel Run Installation

#### 13.1 Eave, End Lap and Ridge/High Eave Pigtail Mastic Installation

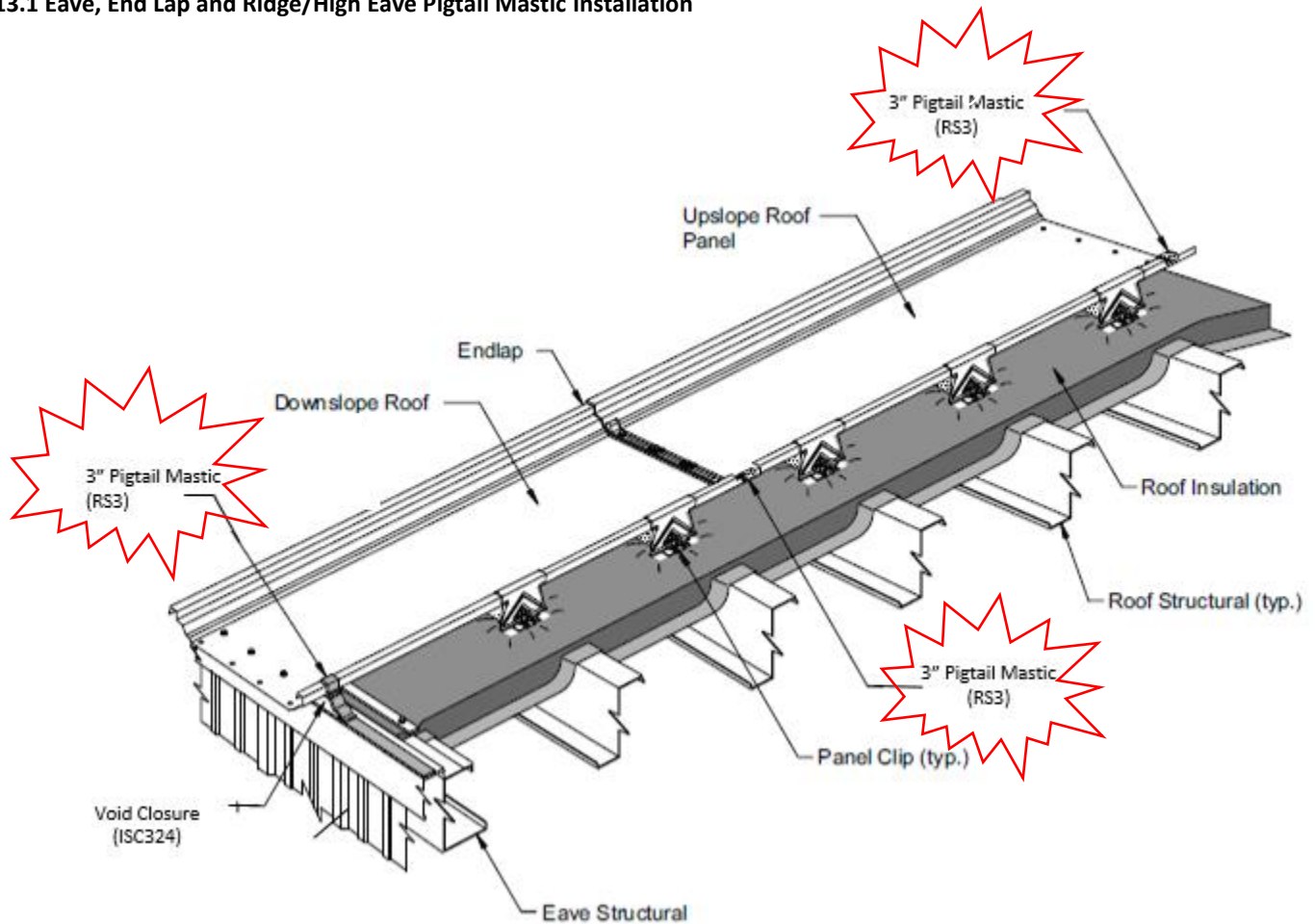

**The 3" pre-cut pigtail mastic (RS3) must be correctly installed BEFORE the next roof panel run can be installed.**

Refer to the next pages for specific pigtail mastic locations and details.

Install these 3" pre-cut pigtail mastics on the leading edge of the roof panel as shown.

### 13.1 Eave, End Lap and Ridge/High Eave Pigtail Mastic Installation

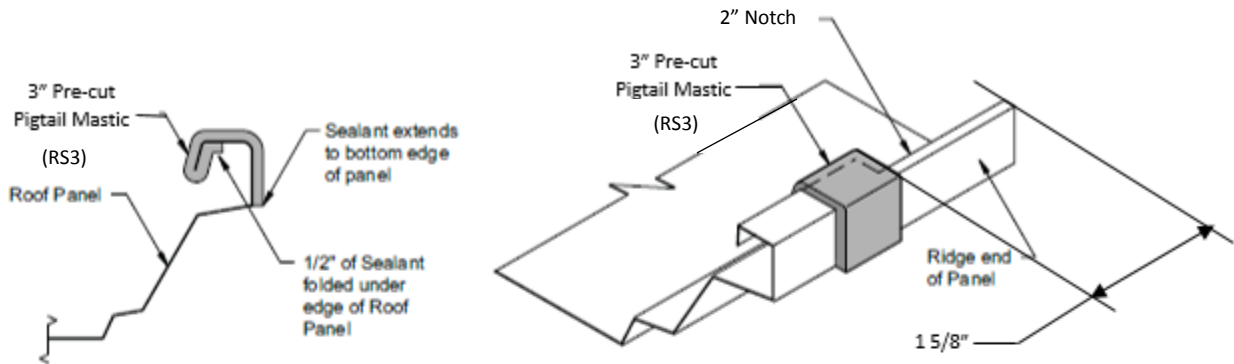

At the high eave location at the panel notch location.

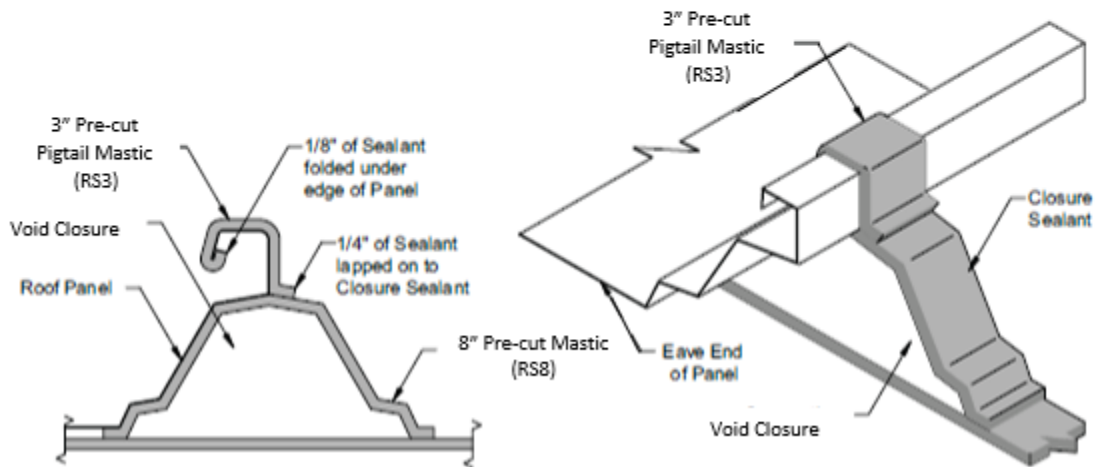

At the low eave over the top of the void closure.

At the ridge, position the 3" pre-cut pigtail mastic (RS3) so its edge is 1- 5/8" from the end of the roof panel. The sealant **must** lap over the edge of the roof panel's notch.

Fold the ridge pre-cut pigtail mastic (RS3) under the edge of the roof panel. The other end of the mastic should extend to the bottom edge of the roof panel's vertical seam.

At the low eave, lap 1/4" of the pre-cut pigtail mastic (RS3) onto the void closure's 8" pre-cut mastic (RS8). Fold the other end under the edge of the roof panel's female hook.

After the pre-cut pigtail mastic is correctly placed, uniformly press the mastic against the panel's surface to assure adhesion.

### 13.1 Eave, End Lap and Ridge/High Eave Pigtail Mastic Installation

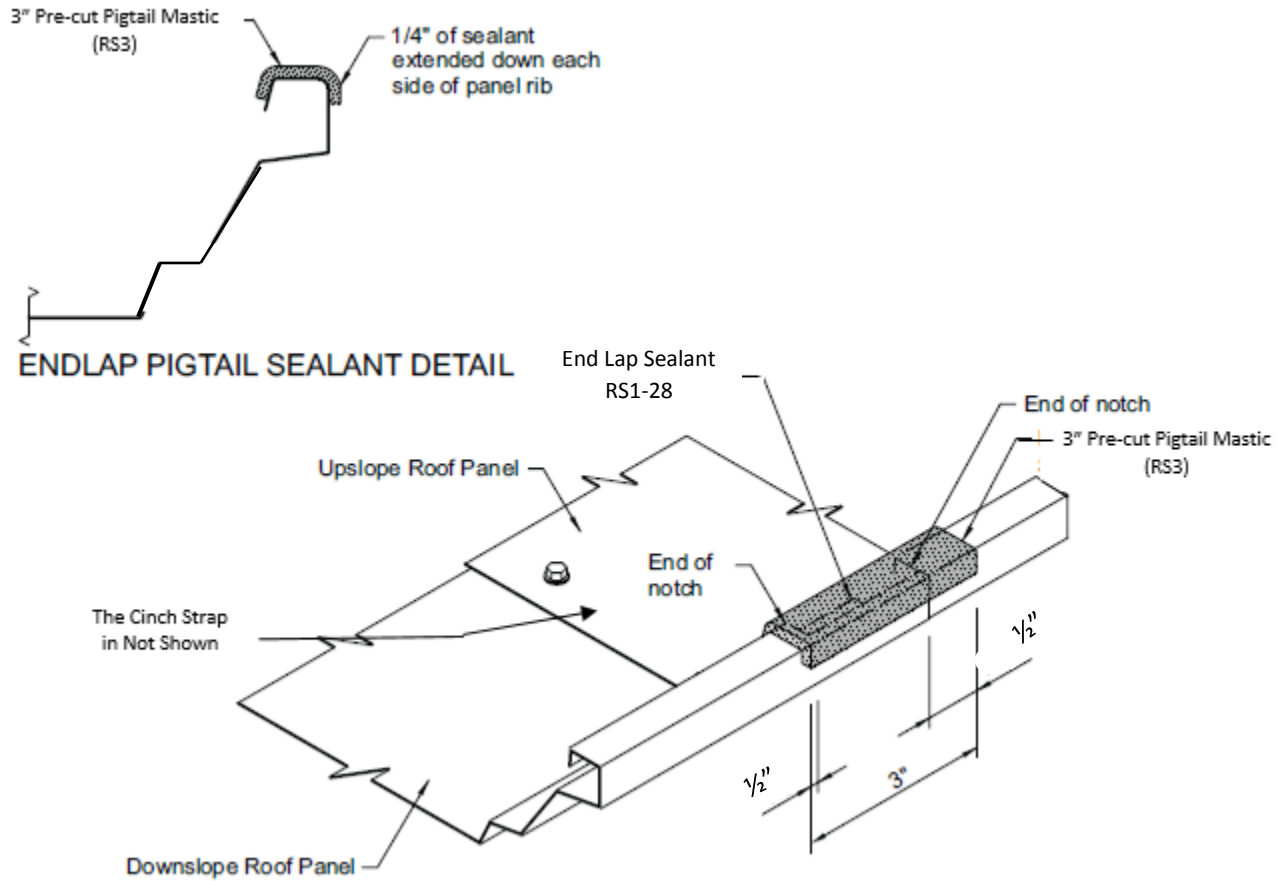

Position the 3" pre-cut pigtail mastic (RS3) to lap 1/2" over the downslope end of the roof panel's notch.

Center the mastic over the roof panel's seam. Fold the edges of the mastic down over the sides of the seam.

Excess mastic in the seams will cause difficult roof panel assembly. Remove any excess mastic. **Cut, do not tear the mastic.**

After the pigtail mastic is correctly placed, uniformly press the mastic against the panel's surface to assure adhesion.

### 13.2 Panel Side Lap Assembly

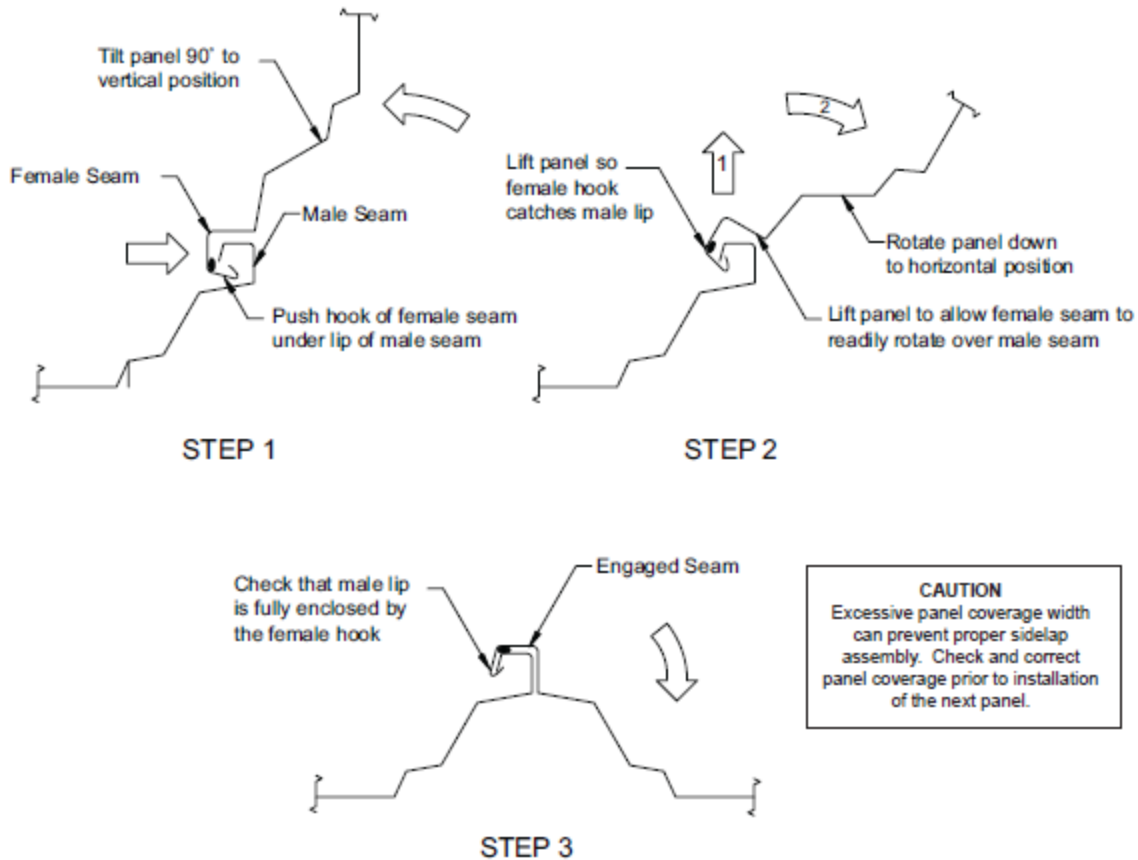

It is easier to hook the roof panel seams together if the roof panel is first tilted up to the vertical position.

With the roof panel in the vertical position, align its female seam to slide under the male seam of the previous roof panel.

With the female seam under the male seam, lift up the roof panel so the female seam's hook catches the lip of the male seam.

While continuing to lift up on the roof panel, rotate the panel down to rest on the insulation and/or thermal blocks.

Be careful **not** to scrape off the factory applied seam sealant during the side lap assembly.

**IMPORTANT:** Check that the male and female are fully nested and the female hook has enclosed the male lip along the **ENTIRE** length of the roof panel. If not, the roof panel side lap **MUST** be correctly re-assembled **BEFORE** installing the next roof panel.

### 13.3 Installing the First Full Panel Run, Starting at the Low Eave

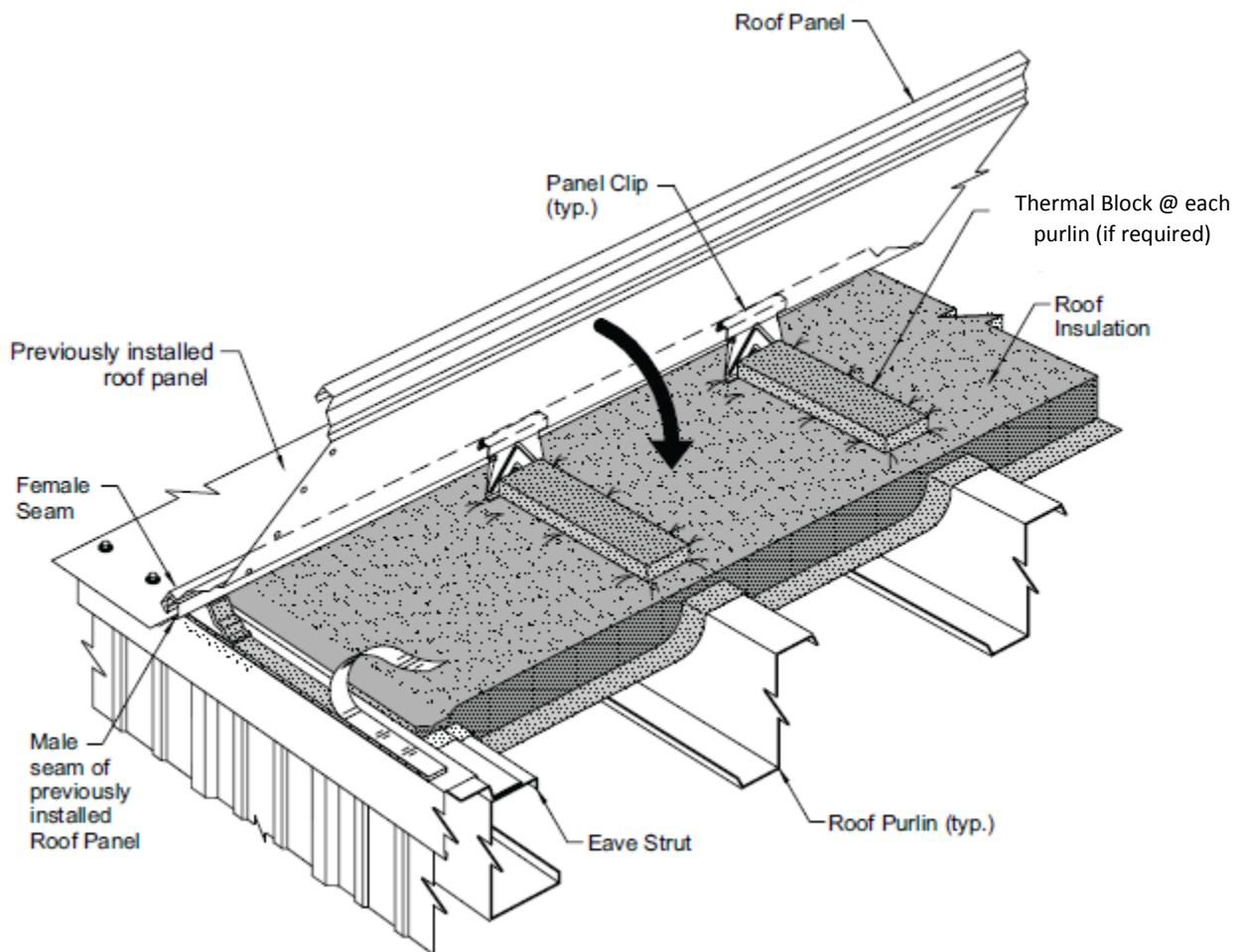

Repeat the previous steps of the first panel run and remove the protective paper from the tape mastic. Remove **only** enough of the protective paper to allow installation of the next roof panel.

If required, place the insulation thermal blocks on top of the insulation directly over the roof structural.

Position the trailing edge (female hook) of the roof panel over the leading edge (male leg) of the previously installed roof panel and position the end of the roof panel 3 1/3" beyond the web of the eave strut.

Tilt the panel as shown so the female seam can be hooked over the male seam of the previous roof panel.

**NOTE: ANY PROTECTIVE COATINGS OR COVERINGS (PRIMARILY ALONG THE PANEL'S TRAPEZODAL RIB ON PAINTED PANELS) MUST BE REMOVED BEFORE ANY PANEL CAN BE INSTALLED.**

### 13.4 Panel Width Modularity

**IMPORTANT NOTE: HAND CRIMPING & MOTORIZED PANEL SEAMING**

As the roof installation progresses, it is necessary to hand crimp and/or mechanically seam the previous panel run. Seaming options differ per project. Refer to the erection drawings for specific seaming requirements. Then review the details of the Seaming Manual.

As a **MINIMUM**, the roof **MUST** be hand crimped into a RollLok (TripleLok) seam profile at the low eave, end lap, high eave, and every clip location at the **END** of **EACH** workday. Failure to do so may result in panels coming off of the roof structural due to high winds.

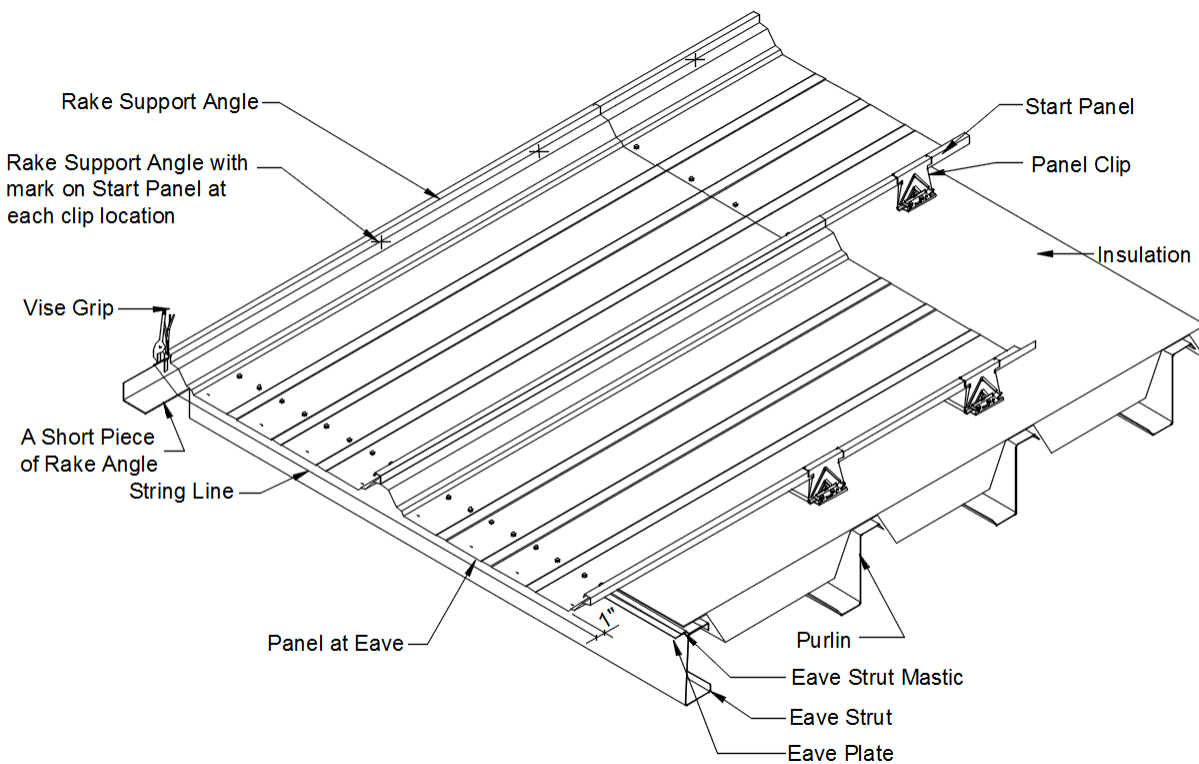

**Before the up-slope panel can be installed, the clips at the leading edge of the down-slope panel MUST be installed. This MUST be done in order so be able to hold panel modularity and so that the end lap detail will assemble correctly.**

**NOTE: At a purlin lap, pre-drill clip fastener locations with 3/16" diameter drill bit – as needed.**

To help hold the correct panel overhang dimension at the eave, install a string line 1-inch past the end of the panels. To do this, clamp a short piece of rake angle to the already installed rake support angle using a pair of vise grips (as shown above).

When installing panel runs, measure back the 1" to properly locate the end of the panels.

**Do Not** Use a tape measure to measure against a possible out of align eave strut. This will cause the panel edge to follow.

It is **important** to carefully measure panel coverage and clip locations at this time. Careful measuring and planning at this stage can save a lot of adjusting and re-work later. Once the clips are properly located, make sure that they are installed in a vertical manner and fully engaged into the secondary framing.



### 13.4 Panel Width Modularity

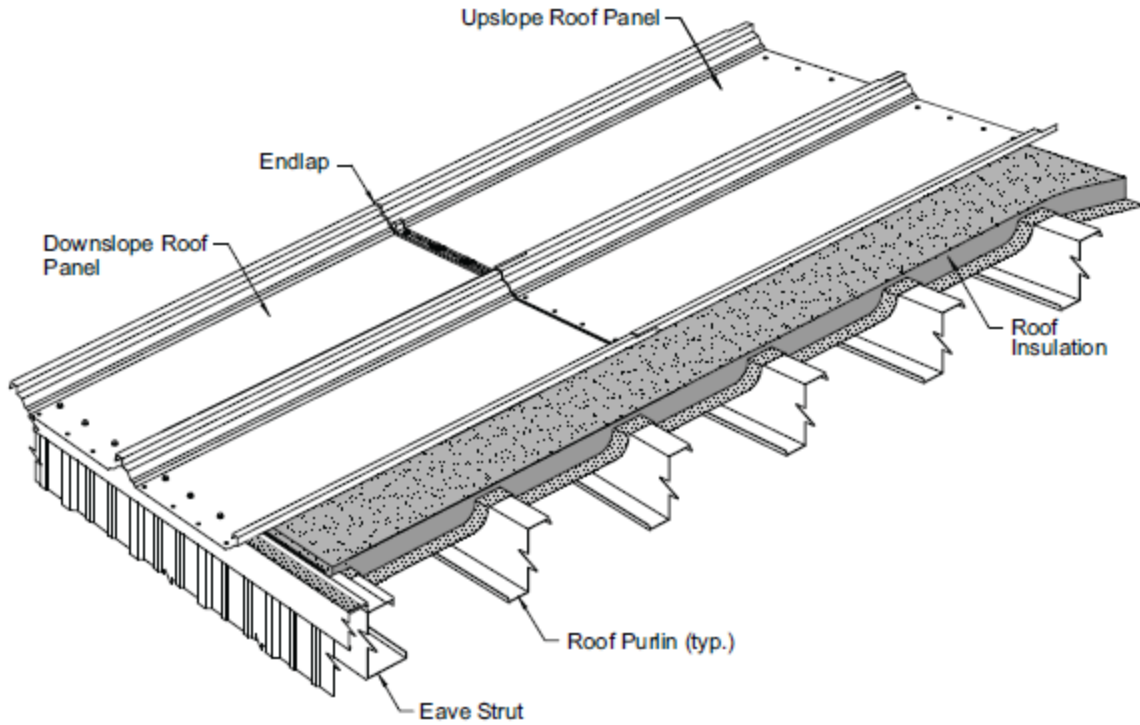

The most common coverage error is the spreading of the roof panels, especially at the panel ends. This can cause excess panel coverage along the eave, end laps and ridge.

If excessive coverage has accumulated over several panel runs, DO NOT try to correct all of the error at one time. Corrected roof panel coverage MUST NOT be greater than 1/8-inch per panel. Correct accumulated coverage error by making the correction over several panel runs.

### 13.5 Adjusting Panel Width Modularity

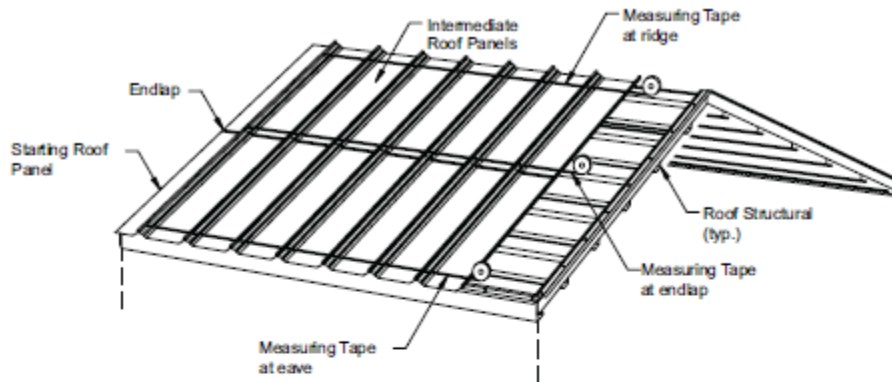

CHECKING PANEL COVERAGE

The coverage MUST be 24-inches O.C. for proper modularity and for the seamer to properly operate.

**NOTE**  
Check modularity of roof every 8 panels.

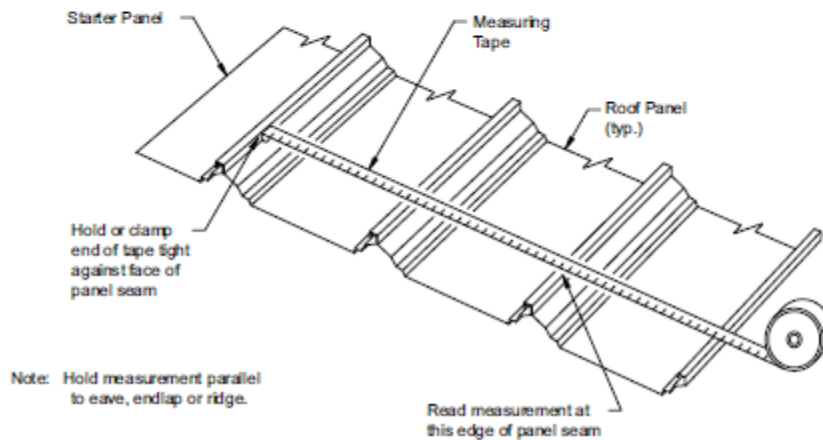

**CAUTION:** To assure proper fit-up of the side lap assembly, proper seaming, proper fit-up of closures, flashing, curbs, etc., it is important that each panel be held to within the 1/8-inch panel coverage tolerance and that overall coverage be checked frequently and any coverage error be corrected BEFORE it accumulates.

To avoid accumulation error, the coverage measurement should always be from the rake line or the starting roof panel's seam.

To avoid measurement error, the measuring tape MUST be free and taut and MUST be parallel to the eave line or ridge line.

Coverage MUST be checked at the eave, ridge and at every end lap.

Improper coverage WILL cause difficulty in seaming.

### 13.5 Adjusting Panel Width Modularity

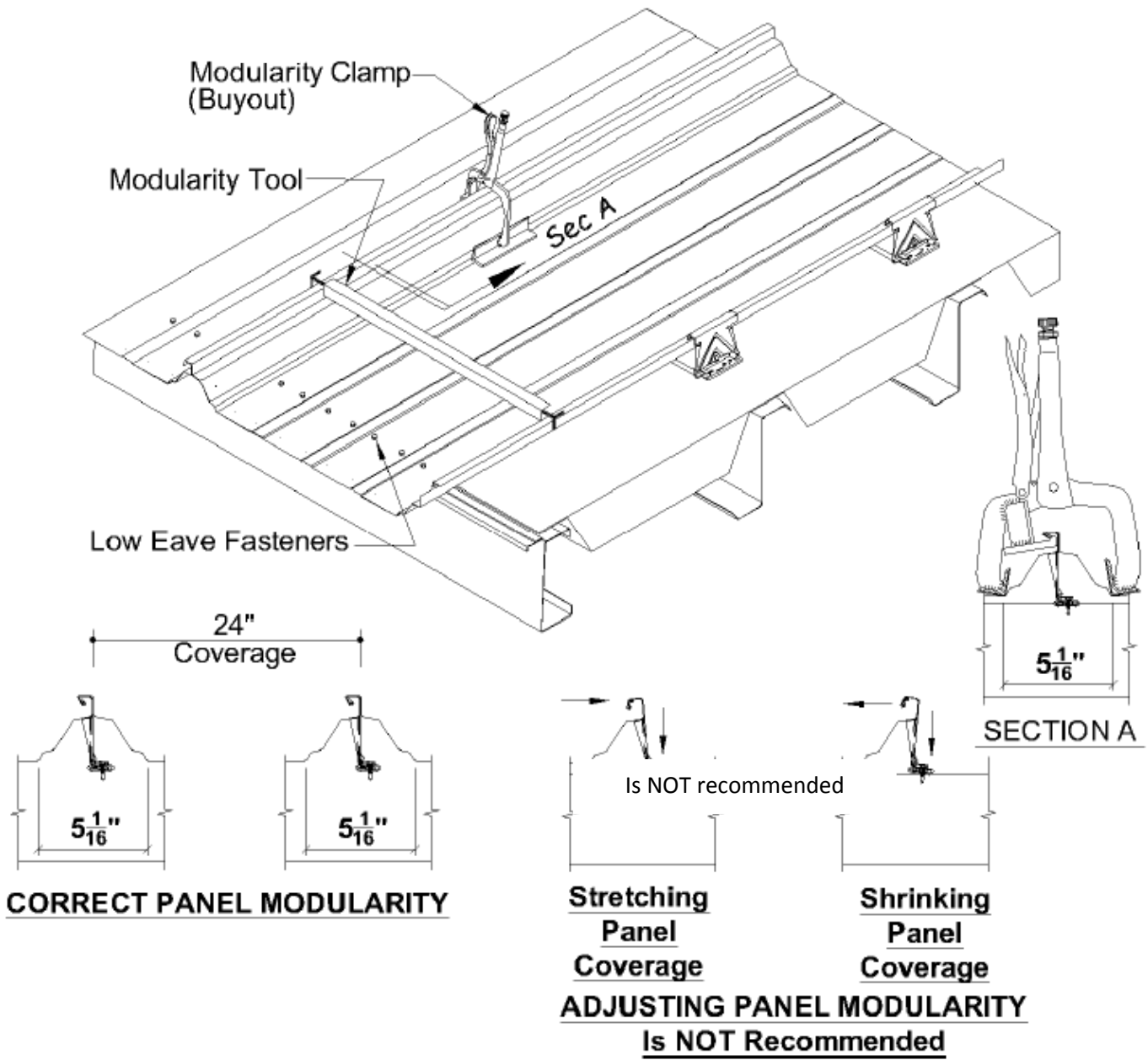

Maintaining panel width modularity is **EXTREMELY IMPORTANT**, as the panels may shrink or grow.

Use a Modularity Tool at the low eave and at **every** panel clip location during the roof installation.

Check the panel width modularity every four to five panel runs by measuring from a fixed plumb line (possibly the end wall steel line) over the completed panel runs.

Measurements should be taken at the ridge, at end laps, at the low eave, and random clip locations on long panel runs. The dimensions at these locations (as well as any other point along the panel run) should be the same.

### 13.6 The Use of an End Lap Clamp

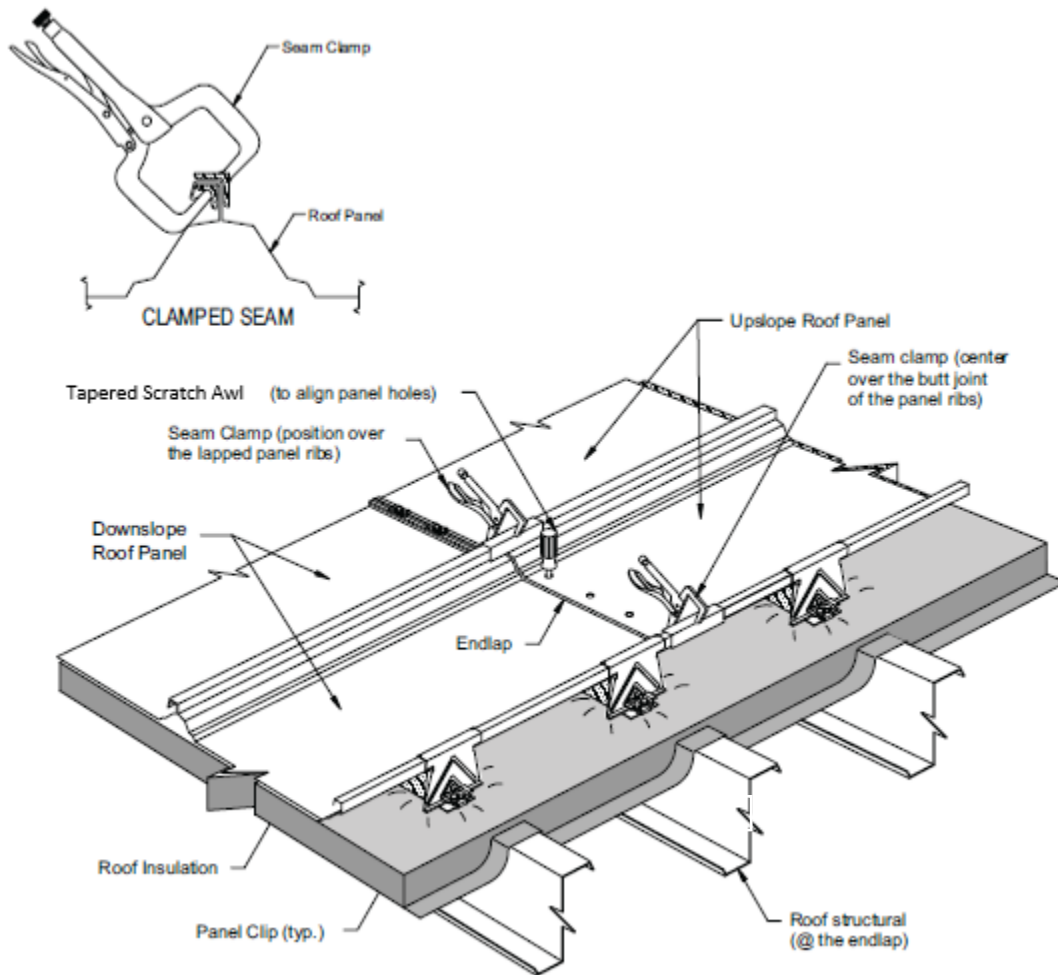

Use the end lap seam clamps to draw the lapping panel seams together, as shown.

Check that the clamp jaws are correctly aligned to the seam before closing the clamp. Misaligned clamps can distort and damage the roof panel seams.

Slowly close the clamp to allow the sealants to flow between the lapped seams.

With the seam clamps installed, uniformly press down on the up-slope panel to close the panel lap and to assure adhesion to the end lap sealants.

**No not remove the seam clamps until after the end lap cinch strap has been installed.**

### 13.7 Installing the Next Panel Run End Lap

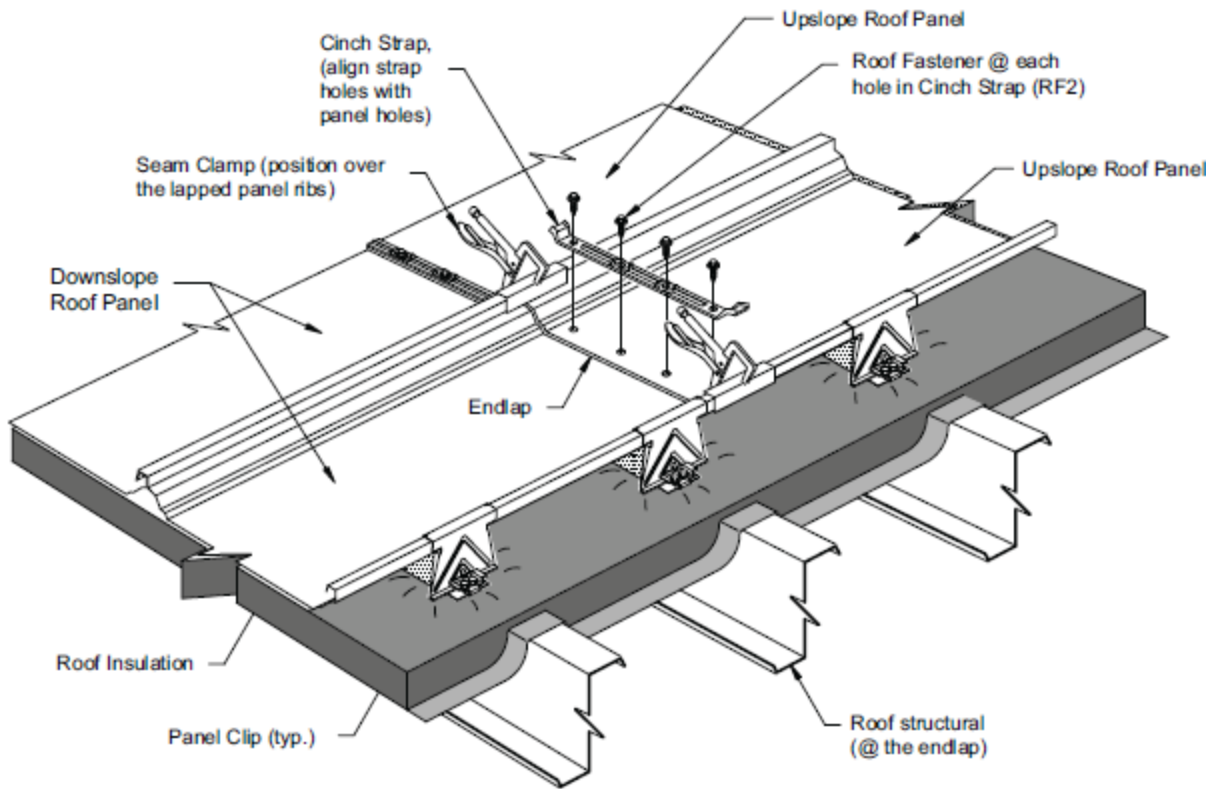

A cinch strap is **required** on all roof end lap applications.

Carefully remove the tapered scratch awls and position the cinch strap over the factory punched holes in the roof panel.

Use the tapered scratch awls to now align the factory punched holes in the cinch strap, both roof panels and the back-up plate.

Install roof fasteners in the open holes. Carefully remove the tapered scratch awls and install fasteners in the remaining holes.

Check that the roof fasteners penetrate thru the center of the end lap mastic and are securely engaged into the back-up plate. A properly installed end lap profile will represent a straight plane. Any sagging appearance is unacceptable and the end lap will require to be reviewed and possibly re-worked.

Remove the seam clamps to complete the installation.

### 13.8 Termination Panel Installation

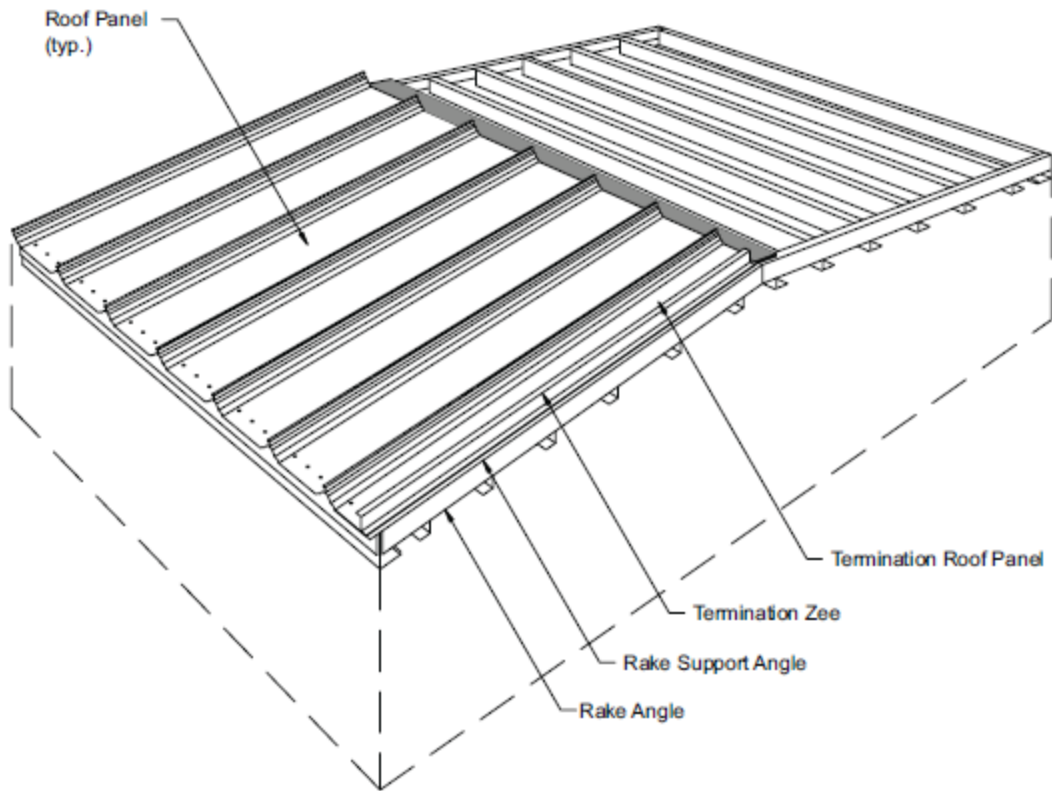

The details in this section show the installation of the termination roof panel.

The details show the termination roof panel installed at the finish rake. These details will show the termination panel finishing “on module” and “off module”.

### 13.9 Termination Panel Installation (On Module)

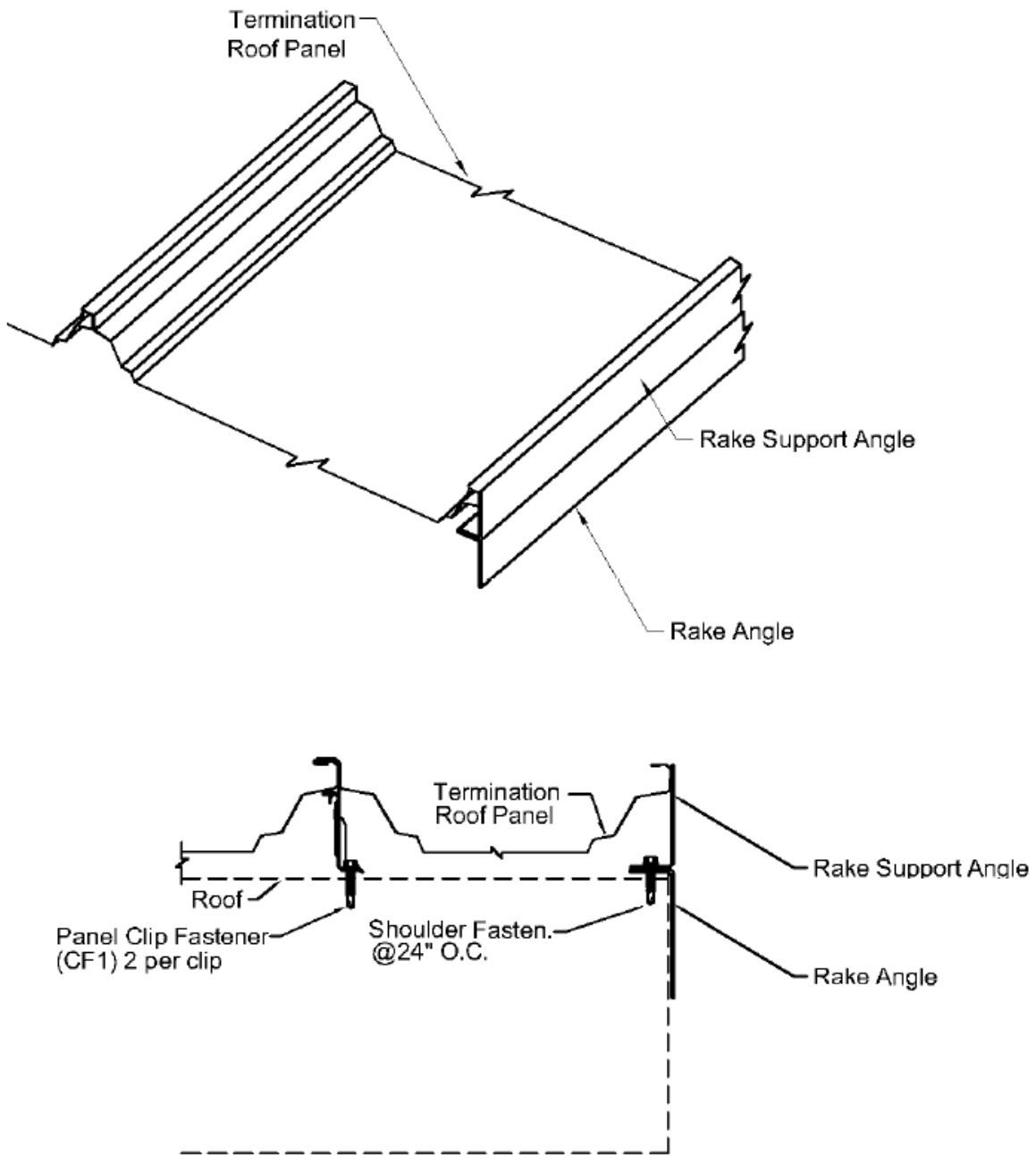

If termination roof panel ends on module at the finishing rake, the male seam of the panel should be against the rake support angle.

To prevent damage or for the panel to blow up with any wind, secure the panel seam to the rake support angle with “C” clamps or temporary fasteners. The panel will not be fastened permanently until the rake trim is installed.

**13.10 Termination Panel Installation (Off Module)**

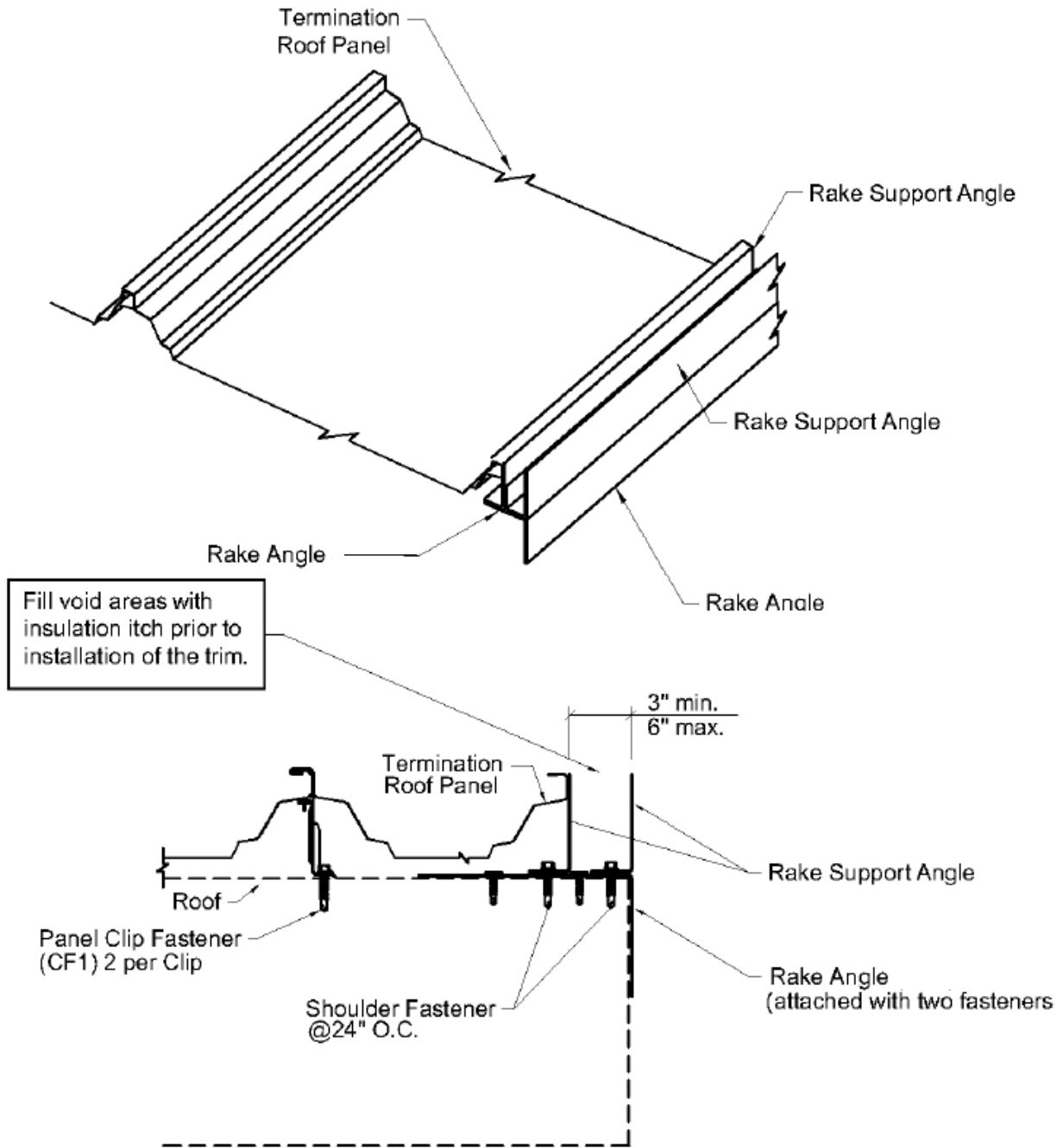

If the termination roof panel ends off module at the finishing rake, attach additional rake angle and rake support angle at the panel end.

To prevent damage or for the panel to blow up with any wind, secure the panel seam to the rake support angle with "C" clamps or temporary fasteners. The panel will not be fastened permanently until the rake trim is installed.

**Insure that the small void between the rake support angles are filled with insulation itch prior to installation of the trim.**



**13.10 Termination Panel Installation (Off Module)**

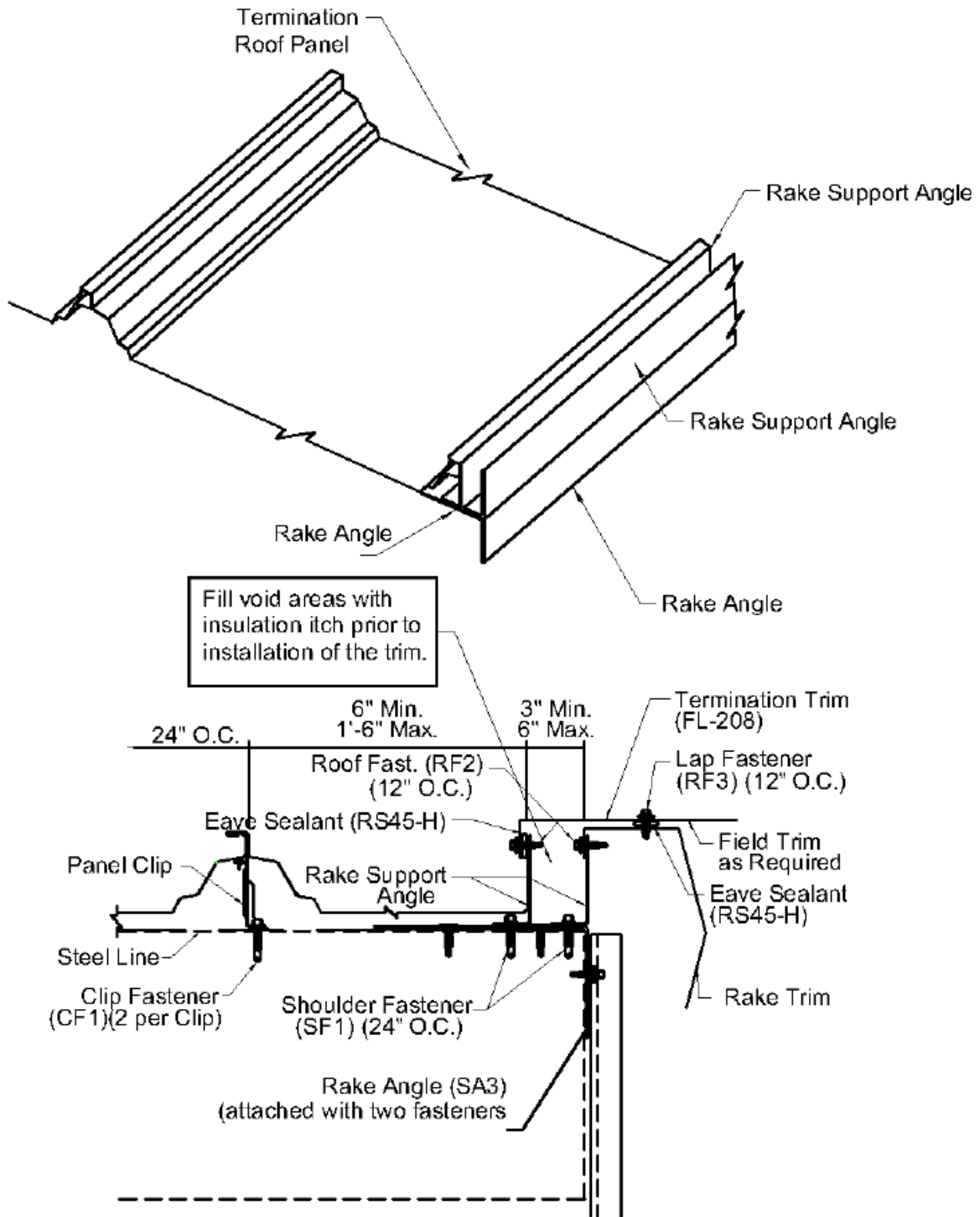

NOTE: Field cut and bend final panel 90° as needed  
 Allow for the vertical leg to extend 3 inches

### 13.11 Outside Closure Installation

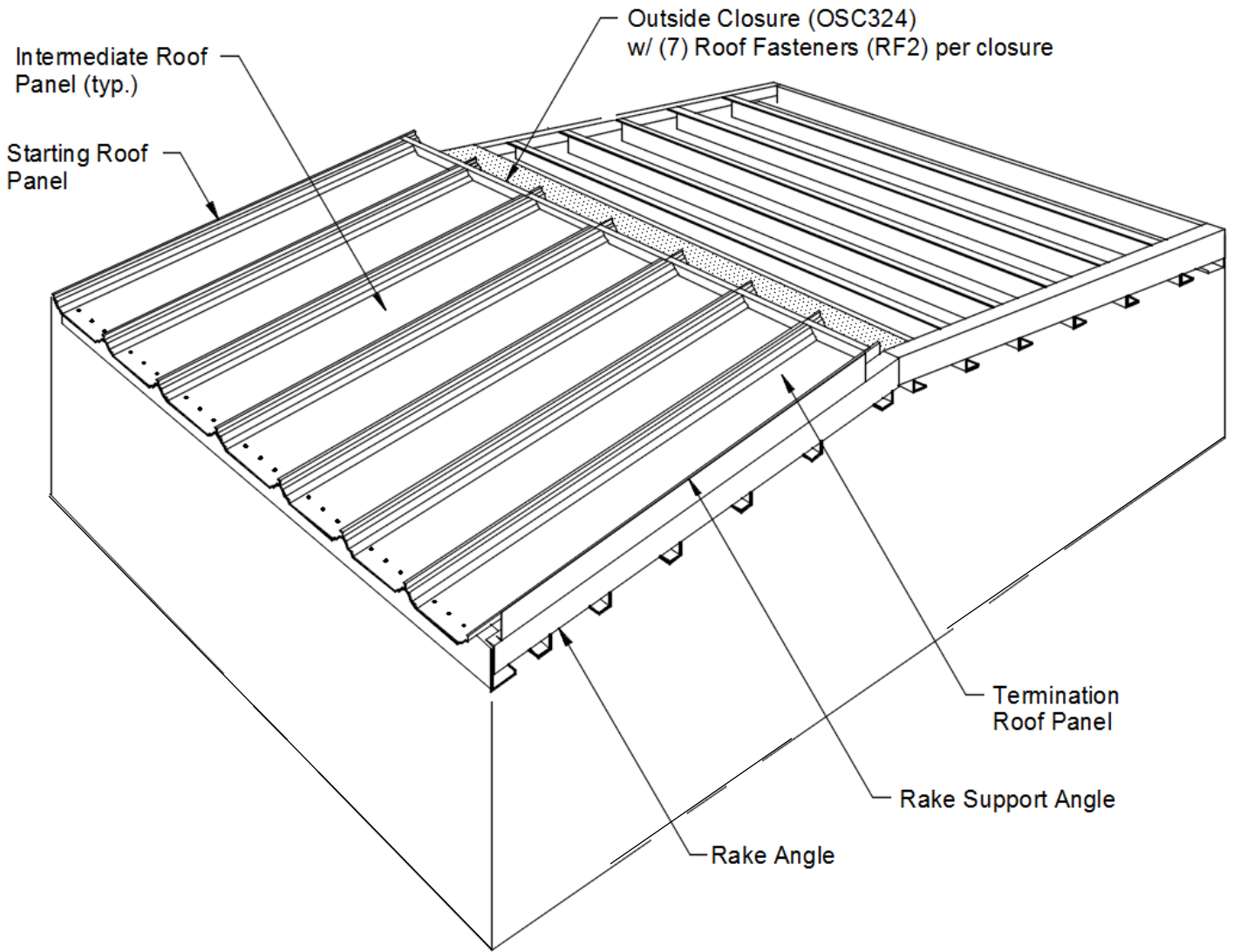

Metal outside closures are to close the ends of the roof panels along the ridge, high eave and high eave transition conditions.

The details in this section will show roof panel preparation requirements and installation of the outside closures.

### 13.12 Outside Closure Installation (Notching of Panel)

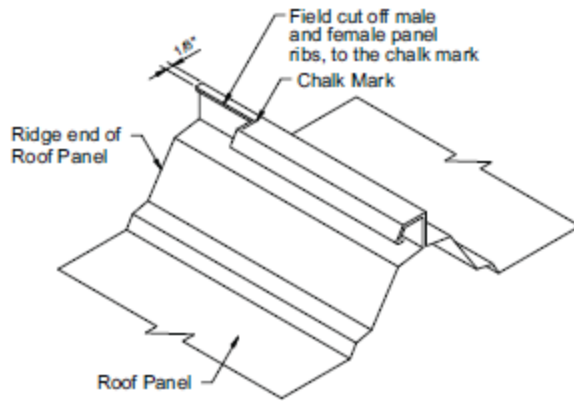

NOTCH FOR RIDGE CLOSURE

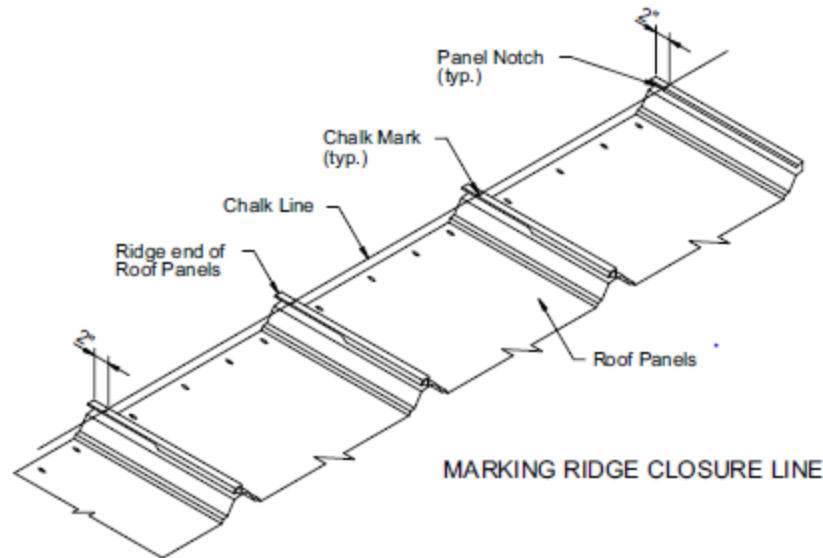

MARKING RIDGE CLOSURE LINE

**BEFORE INSTALLING ANY MORE PANEL RUNS, THE OUTSIDE CLOSURE IN THE PREVIOUS PANEL RUN MUST BE INSTALLED. THIS IS A CRITICAL STEP IN HOLDING PANEL WIDTH MODULARITY, AND TO AVOID SIGNIFICANT FIELD WORK LATER ON. INSTALLATION AFTER THE ROOF PANELS ARE IN PLACE CAUSES COVERAGE ERRORS AND MAY PREVENT PROPER INSTALLATION. AS WORK PROGRESS'S, INSTALL THE OUTSIDE CLOSURE IN THE PREVIOUS PANEL RUN.**

Check the alignment of the roof notches along the ridge. They should be in alignment if the modularity was held. If the notches are staggered more than ¼-inches, use a blue chalk line to establish a straight notch line. Position the chalk line so no notch extends below the line.

Using the end of the factory notch (or chalk marks) as a guide, field cut the additional notching required in both male and female portions of the seam as shown.

Hand seam 16-inches of the uphill panel end **BEFORE** installing tape mastic and the outside closure to accommodate the motorized seamer.

### 13.13 Outside Closure Installation (Installing the Backup Plate)

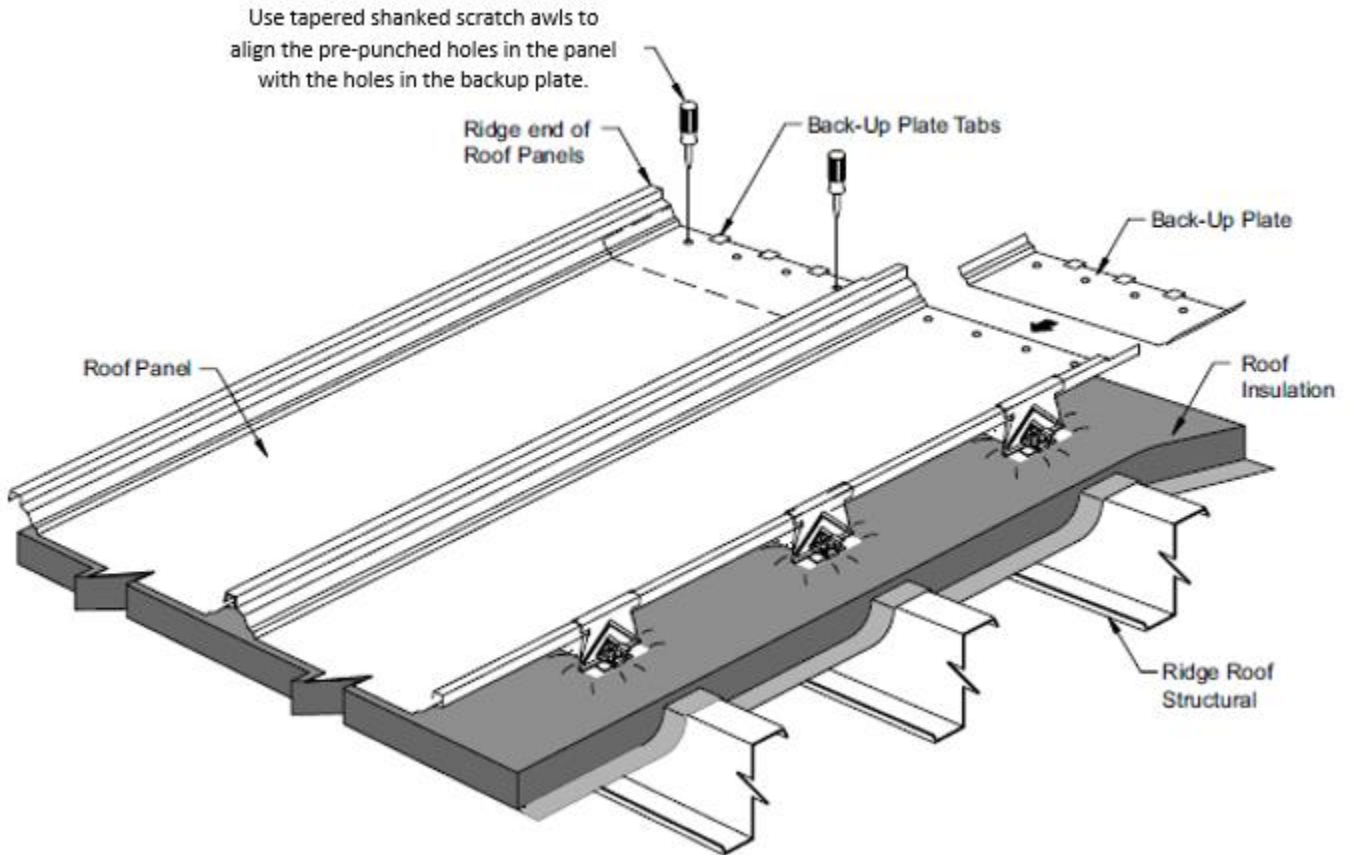

Before installing the outside closure, the backup plate **MUST** be installed. Slide the backup plate onto the end of the roof panel, aligning the backup plate with the panel corrugation and pre-punched holes.

**NOTE:** In the case of interference at the high eave/ridge end of the panel (parapet wall, existing gutter, etc.) slide the backup plate onto the panel **PRIOR** to laying the panel into place.

The backup plate **MUST** be set over the top of the roof structural. If insulation thermal blocks are used, the backup plate **MUST** be set over the thermal blocks.

If the ridge purlin is located too far down slope for the backup plate to rest on the purlin or thermal block, use a clamp to hold the backup plate in position until after the fasteners are installed.

The backup plate's tabs **MUST** hook over the end of the roof panel.

Use tapered shanked scratch awls to align the holes in the backup plate with the factory punched holes in the roof panel.

### 13.14 Outside Closure Installation (Applying the Tape Mastics)

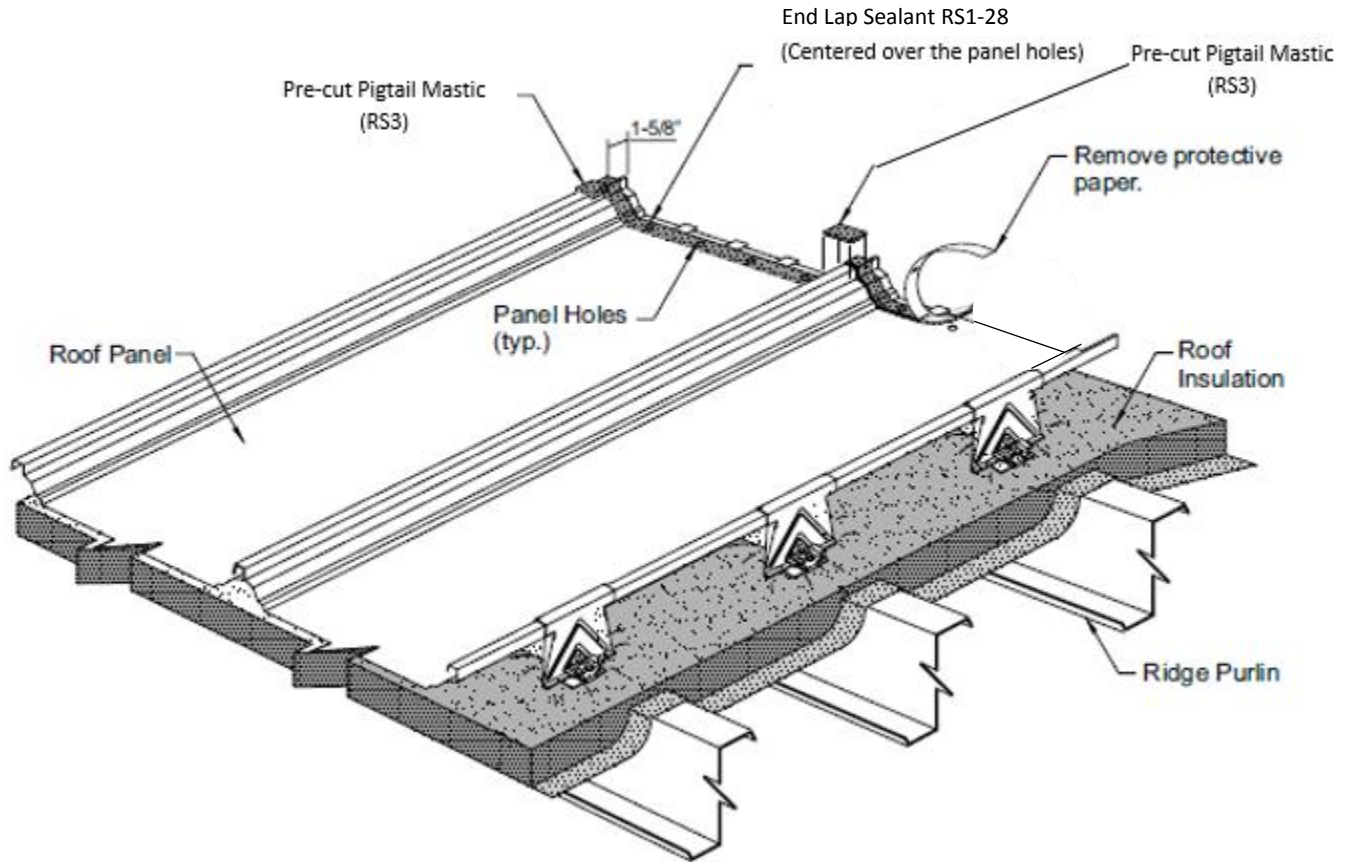

NOTE: Hand crimp the upper part of the roof panel into a TripleLok seam profile PRIOR to installing the tape mastic and outside closure.

Before installing the mastic and outside closure, the roof's surface MUST be wiped clean and dry.

Install a strip of the 28-inch pre-cut mastic (RS1-28) along the end of the roof panel as shown.

Position the mastic so that its down-slope edge is uniformly 1 5/8" from the end of the panel. This will leave roughly 1/8" of panel edge visible to apply Butyl tube sealant on later. The tape mastic MUST be centered over the roof panel's factory punched holes.

Be sure to check that the mastic fully contacts the roof panel's surface and that it is completely fitted into the panel corners and around the seams.

Install a strip of the 3" pre-cut mastic (RS3) over the panel side lap as shown.

Specific mastic application details are shown on the following page.

**13.14 Outside Closure Installation (Applying the Tape Mastics)**

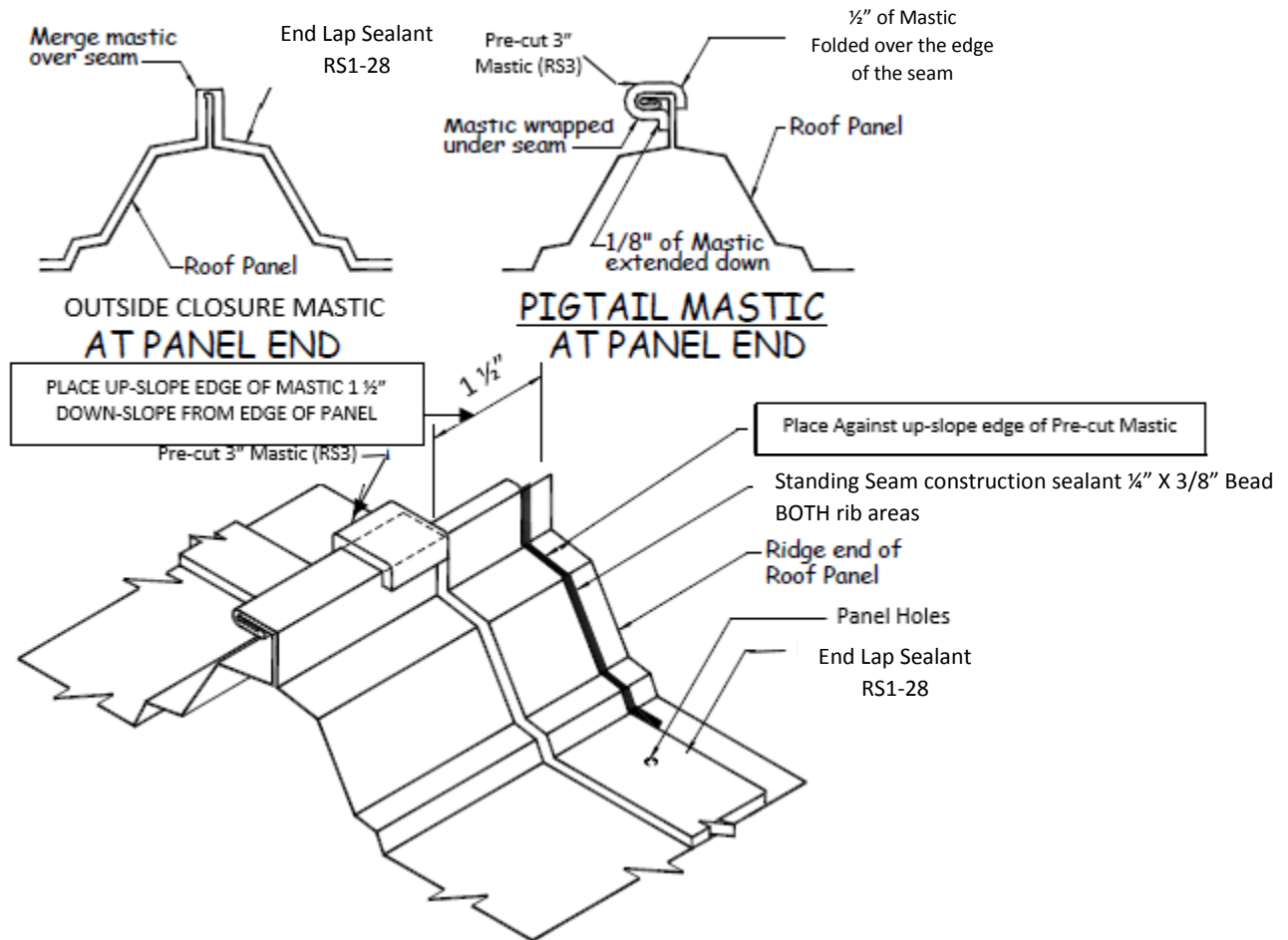

**THE CORRECT INSTALLATION of the outside closure is critical to the weather tightness performance of the roof system.**

**Be sure to verify that the mastic is installed as shown above BEFORE installing the outside closures.**

**PROIR to installing the outside closure mastics, hand crimp the panel seam to form a TripleLok profile.**

After the mastic is correctly positioned, uniformly press the mastic against the roof panel surface to assure adhesion. DO NOT use excess pressure, which can thin the mastic.

Install a bead of Butyl tube caulk in the rib area of the panel (at both ends) as shown in the detail below. The caulk should be adjacent to, and up-slope of the mastic.



### 13.15 Outside Closure Installation

Use tapered shanked scratch awls to align the pre-punched holes in the outside closure, in the panel and with the holes in the backup plate.

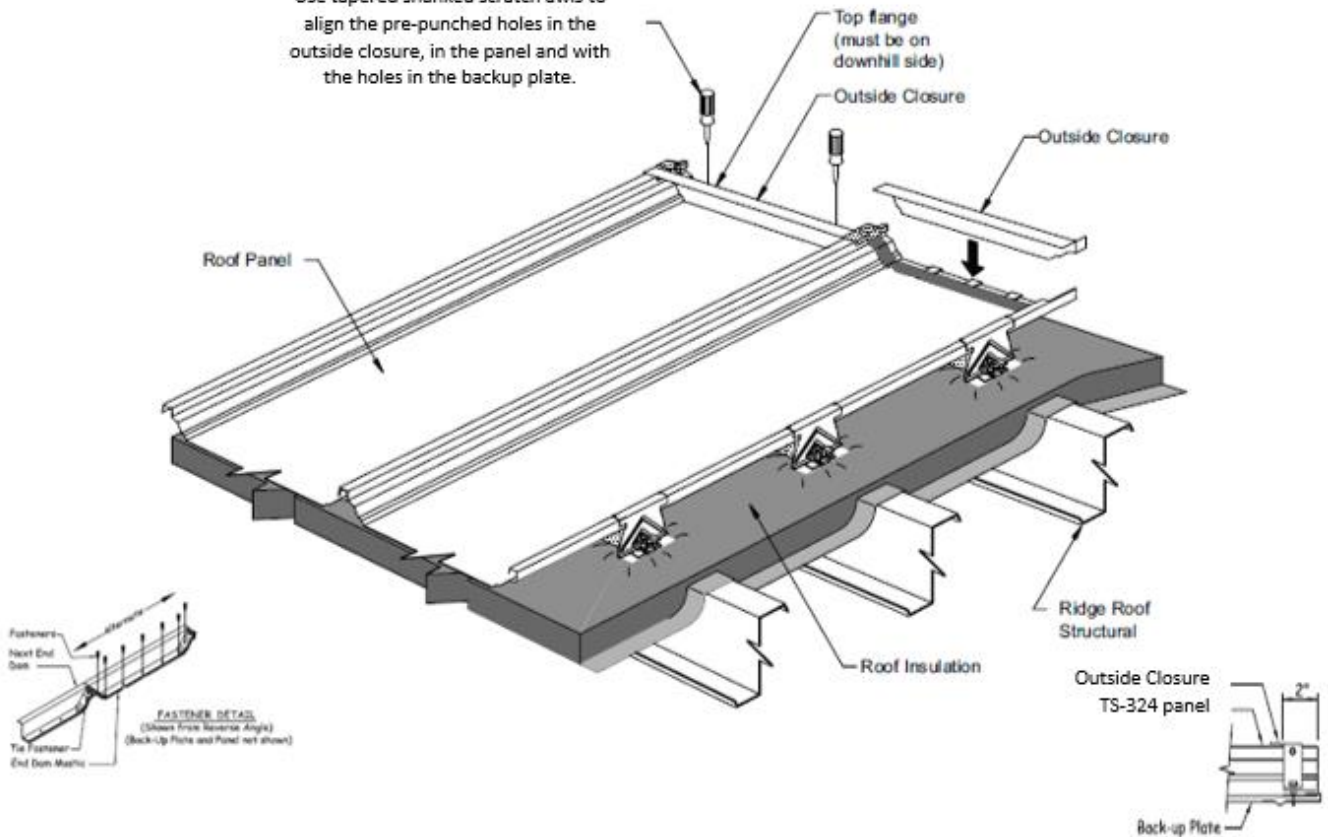

Wipe dry and clean the underside of the surface of the outside closure (OSC324).

Remove the protective paper from the 28-inch and 3-inch long pre-cut mastics (RS1-28 & RS3).

Position the outside closure so the top flange is turned down-slope and the bottom flange is up-slope. Position the bottom flange **directly** over the outside closure tape mastic. Uniformly press the outside closure down into the tape mastic. To assure adhesion, use clamp(s) to hold the assembly together while installing the fasteners. Make sure that the vertical face of the outside closure is at the 2-inch notch as shown.

Install the fasteners, starting from the center of the closure, alternating fastener pattern towards the outside of the closure, as shown below.

Install the shoulder fasteners last.

Check that the fasteners penetrate through the tape mastic and are securely engaged into the backup plate.

Next, check that the vertical face of the closure is perpendicular to the roof panel and aligned with the previously installed closure. If not, push the top of the closure to the correct position.

After the next closure is installed, add one self-drilling tie fastener through the hole at the top of the closure, through the roof panel seam and into the opposite closure.

Check that there are no unsealed voids between the roof panel and the closure, especially in the critical areas around the roof panel and seams.

**IMPORTANT: Be careful NOT to displace or damage the mastic while installing the outside closure. Over-tightening this fastener will squeeze the roof panel side lap assembly together and effect the roof panel coverage width. Carefully tighten the fastener ONLY as necessary to maintain the correct panel width.**

13.15 Outside Closure Installation

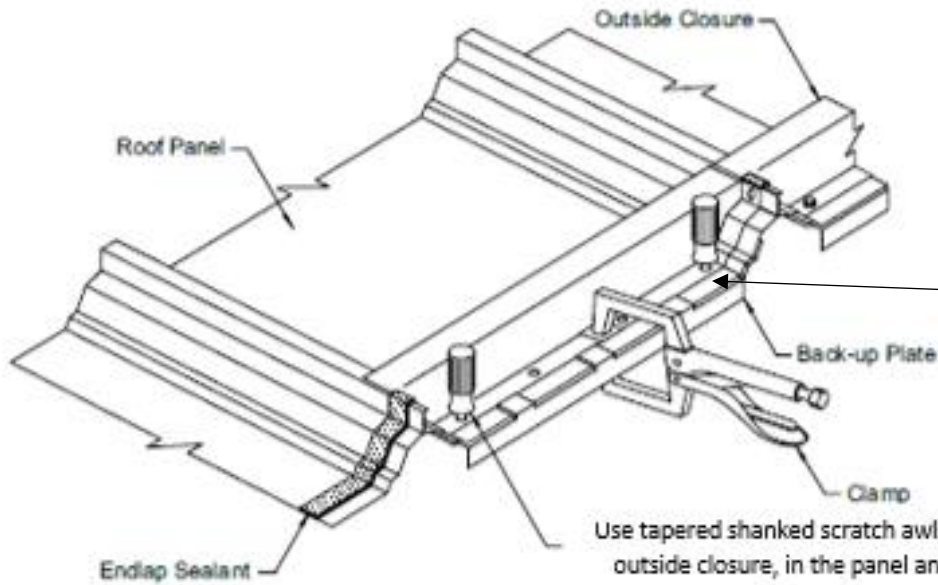

**NOTE:**  
 The back upslope edge of the outside closure bottom flange should be against the down slope edge of the back-up plate's tabs. Do not install the outside closure on top of the back-up plate tabs.

OUTSIDE CLOSURE ALIGNMENT

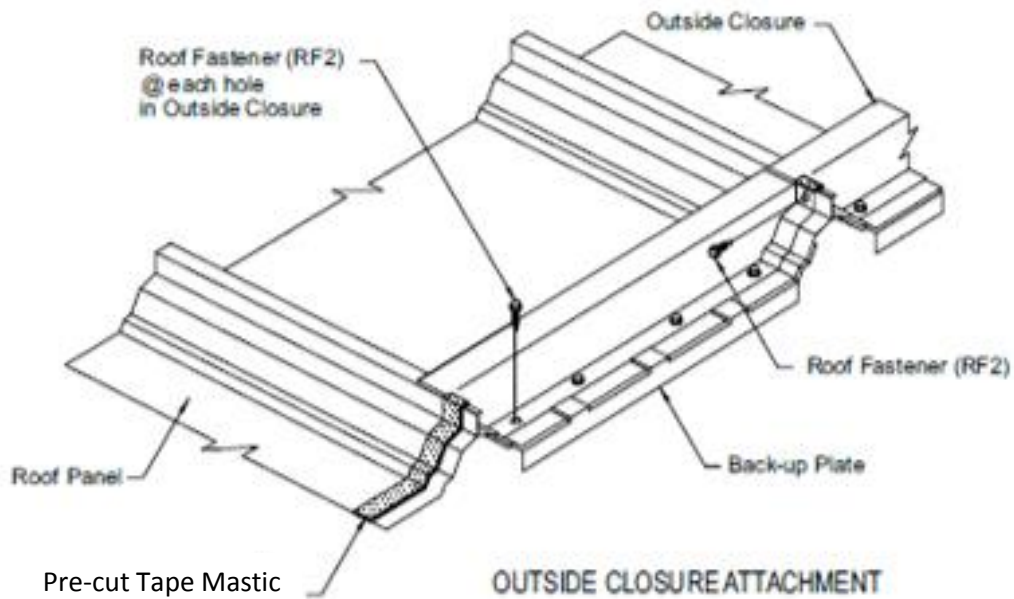

OUTSIDE CLOSURE ATTACHMENT



### 13.15 Outside Closure Installation

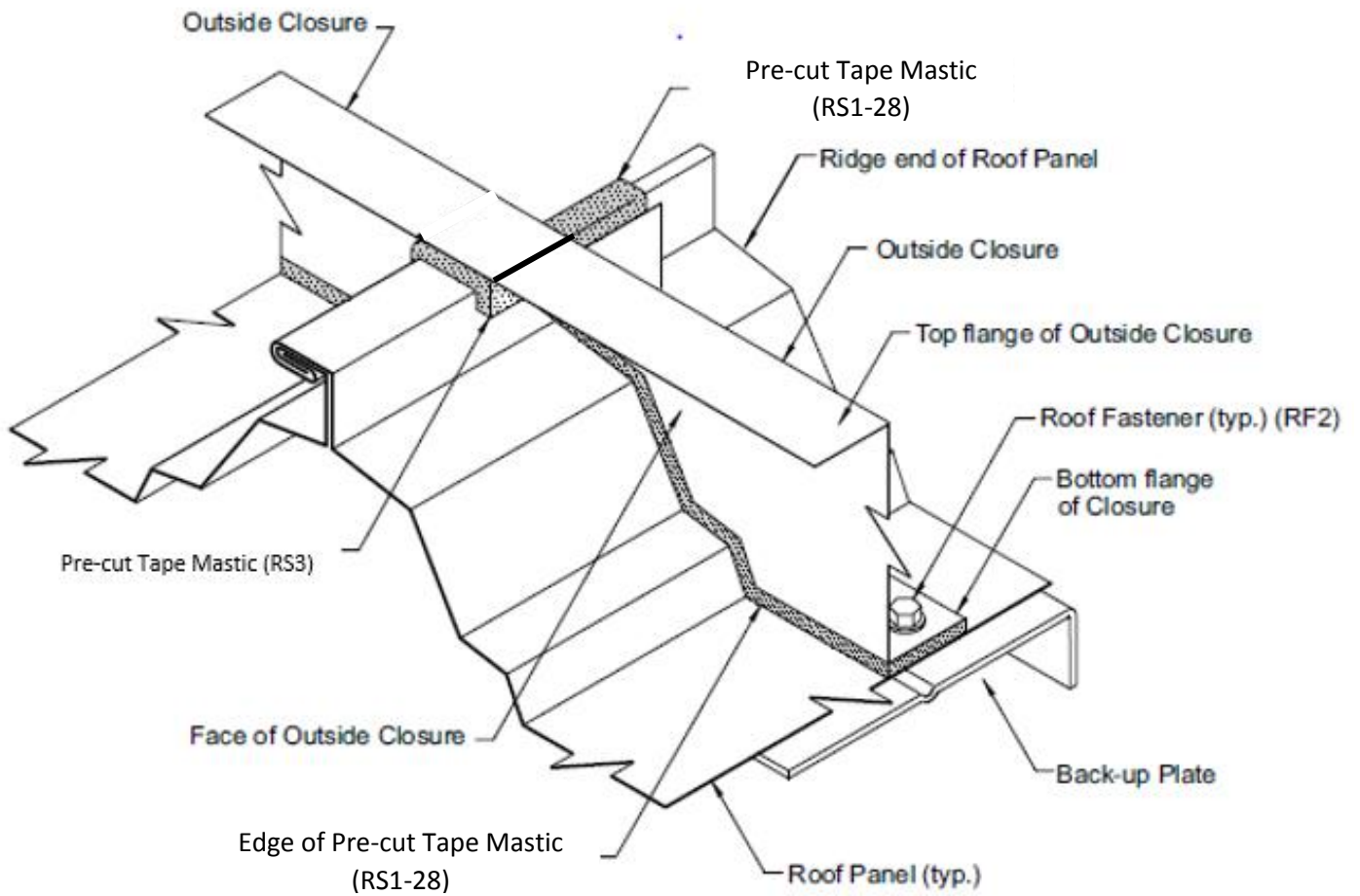

Verify that the outside closure is correctly assembled as shown.

Check that there are no un-sealed voids between the roof panel and the outside closure, especially in the critical areas around the roof panel ribs and seams.

**13.16 Outside Closure Installation at a Modification of a Termination Panel**

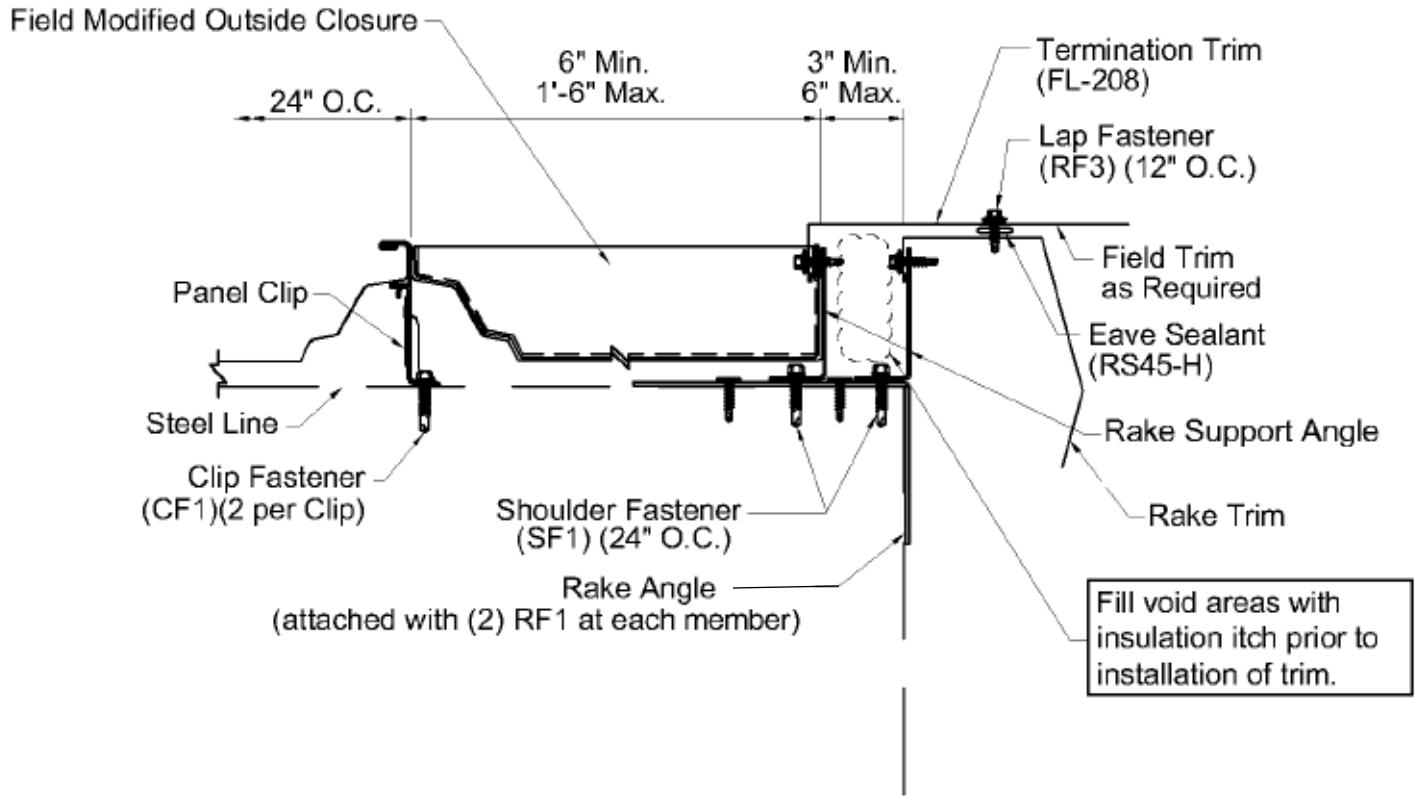

When your termination roof panel requires to be ripped and then a 3-inch field formed vertical leg is required to be formed, the outside closure will also require to be field modified to properly fill this area.

Field cut an outside closure to fit between the rake support angle and bent leg of the roof panel. Add 1-inch to the web of the closure to form a tab to attach the closure to the rake support angle.

Apply part of a piece of pre-cut tape mastic (RS1-28) to the roof panel and up the vertical side against the rake support angle where the tab will be attached.

Apply a bead of Butyl standing seam construction sealant in the rib area of the panel and along the back leg of the rake support angle. The caulk should be adjacent to and up-slope from the tape mastic.

Fasten the closure at the pre-punched holes with self-drilling screws.

Fasten the field fabricated tab of the closure to the rake support angle with (2) self-drilling screws.

If applicable, install (1) self-drilling tie fastener through the hole at the top of the closure into the adjacent closure.

(See Next Page)

13.16 Outside Closure Installation at a Modification of a Termination Panel

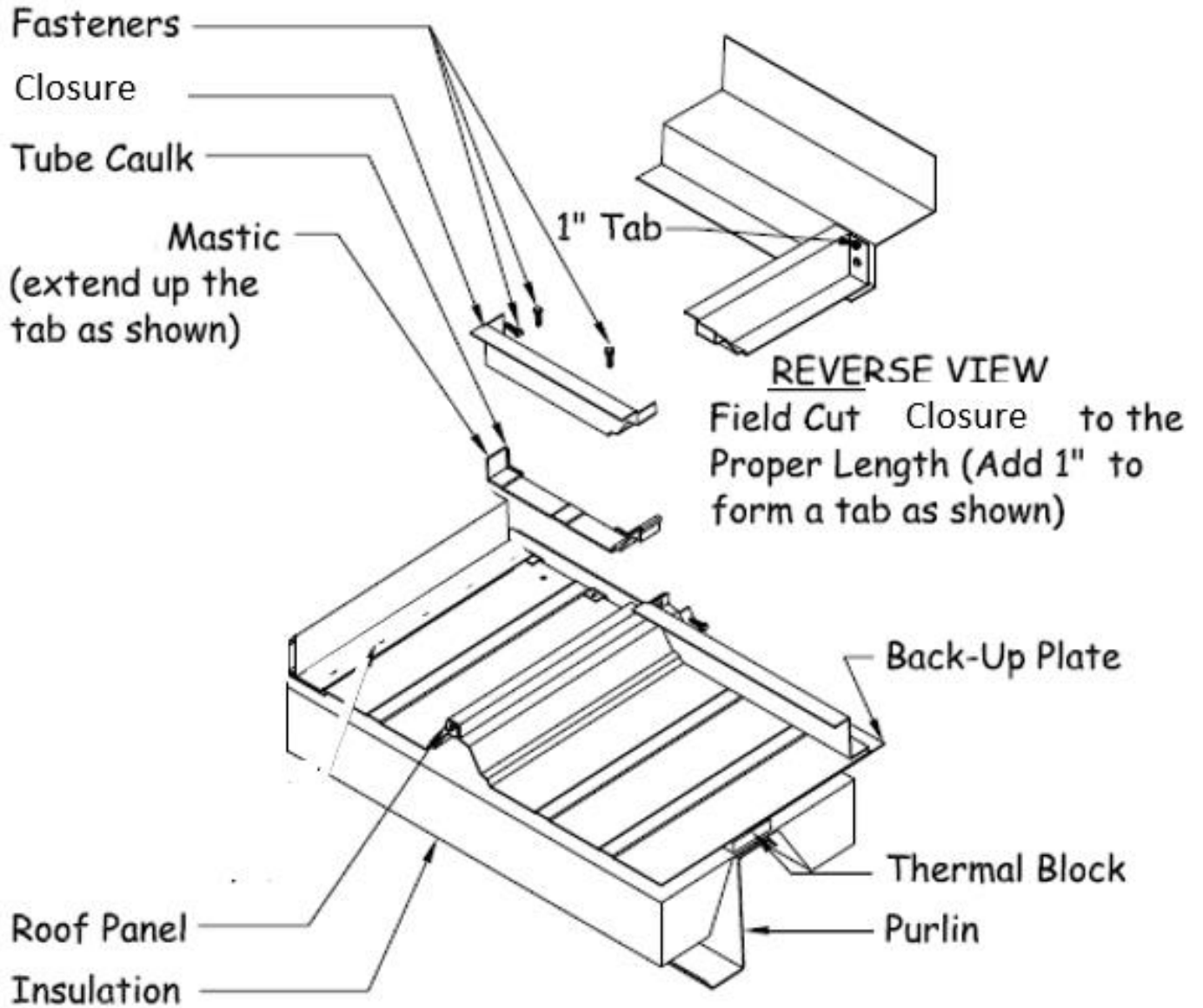

### 13.17 Hand Crimping/Motorized Panel Seaming

#### Hand Crimping/Motorized Panel Seaming

As the roof installation progresses, it is **NECESSARY** to hand crimp and/or mechanically seam the previous panel run. Seaming options differ per project. Refer to the erection drawings for specific requirements. Then review the details in the Seaming Manual.

#### NOTE:

As a **MINIMUM**, the roof should be hand crimped into a TripleLok seam profile at the low eave, each end lap, the high eave, and at every clip location at the **END of EACH workday**. Failure to do so may result in panels coming off of the roof due to high winds.

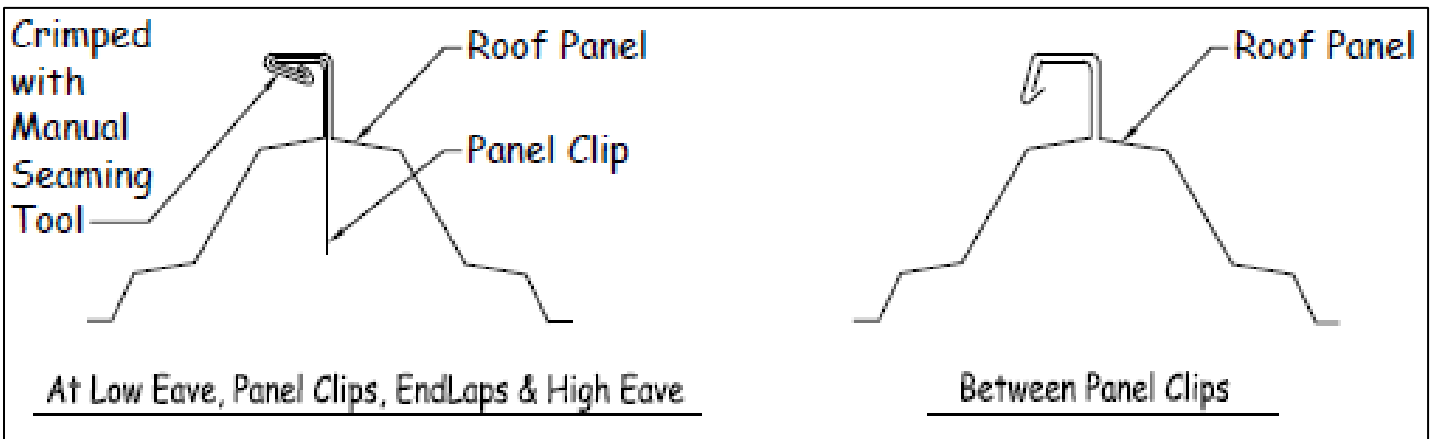

## 14.0 Preparation for Roof Line Trim Installation

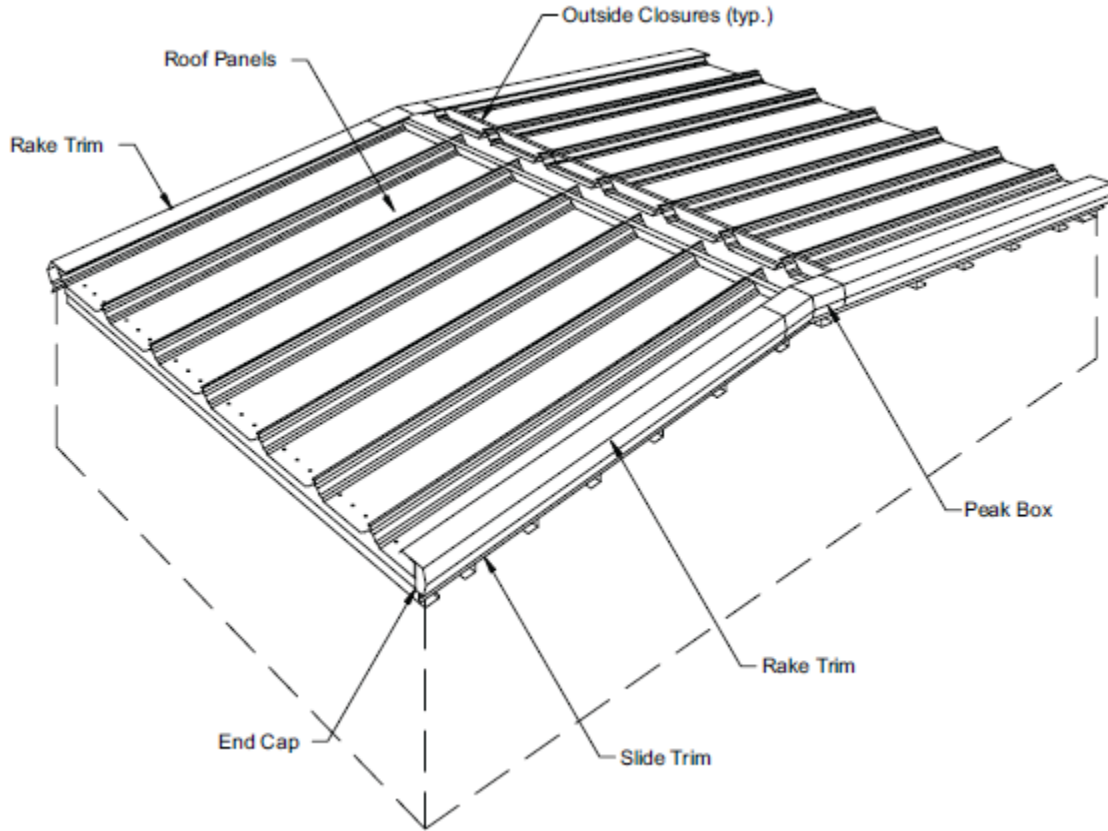

The details in this section show the installation of the rake trim, peak box, and the end caps. The details at a starting roof panel condition are similar.

These details show the rake trim at a termination roof panel condition.

## 14.0 Preparation for Roof Line Trim Installation

### 14.1 Preparation for Trim Installation

**BEFORE PROCEEDING WITH THE ROOF LINE TRIM INSTALLATION, WALK THE ROOF PAYING PARTICULAR ATTENTION TO THE FOLLOWING AREAS:**

**ALL** panel splices are straight, fasteners are properly installed.

**ALL** outside closures are in place and properly fastened, including the fastener through the panel seam.

**ALL** outside closures are the same height and in a straight line.

**ALL** gaps between the panel and the outside closure have been properly filled with caulk.

**ALL** void closures are in place and properly fastened and aligned.

**ALL** gaps between the panel and void closures have been properly filled with caulk.

**ALL** metal shavings and debris have been removed from the roof.

**ALL** perimeter fasteners are in place and properly tightened. The EPDM washer should be visible all around the fastener.

### 14.2 General

Begin installing trim at the back of the building working towards the front. This will "hide" the trim laps from direct view.

When lapping the rake trim and rake parapet trim, the upper piece should overlap the lower piece. This will help prevent water from entering into the building through the lap.

**Gutter/Rake Trim (bird stops) MUST be installed PRIOR to the installation of the low eave trim.**

Some field cutting, trimming, and bending is required. **Extreme care MUST be taken while performing any fieldwork so as to produce an attractive, weather tight condition.**

Refer to your project erection drawings and the following pages for trim part numbers.

**NOTE:** MS Polymer tube caulk is applied at all trim laps **except** at the ridge cap. The ridge cap utilizes the **Butyl** standing seam tube caulk.

**It is IMPORTANT that the CORRECT caulk be used. Careful attention to the details is a MUST.**

A check list is provided at the end of this manual for punching out the roof.

This section is broken down into individual trim conditions. Not all of these conditions may apply to your project. Refer to the erection drawing roof sheeting plan(s) and the roof line trim details to identify the conditions your project requires.

If there are discrepancies between this manual and the erection drawings, the erection drawings will take precedence. It is a good idea to compare the erection drawing details against this manual before trim installation begins.

Refer to the following pages for standard roof line trim profiles for assistance in the correct selection and identification of roof line trim parts. For proper fit-up, sealing and fastening, and to help ensure the roof assembly's weather tightness, structural capability, durability and appearance, the correct parts **MUST** be used. **DO NOT** use parts other than those specified in this manual or on the erection drawings without consulting Horizon Building Systems.

**Before installing any roof line trim, the wall panel (or whatever wall material is being used) MUST be erected.**

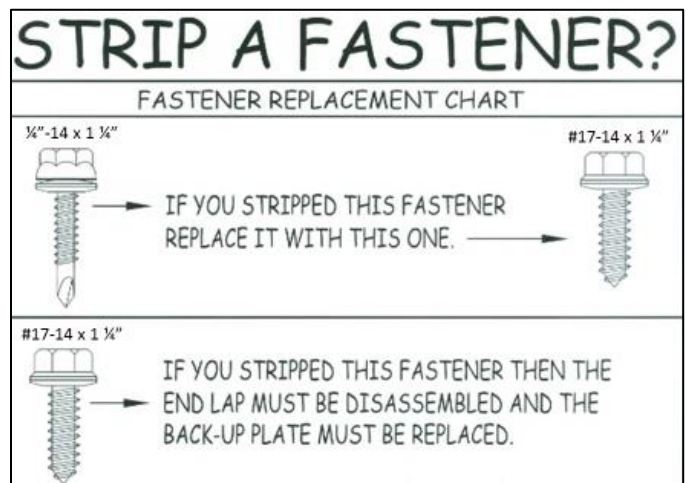

**15.0 Standard Roof Line Trim Parts**

**15.1 General**

This section is intended to show you diagrams of the trim that are used in this section of the manual. These parts cover the standard conditions. The erection drawing details will cover the special conditions.

It is a good idea to check the erection drawing details against the details in this section. If there are any discrepancies, the erection drawings will take precedence.

**Eave Trim  
FL-214**

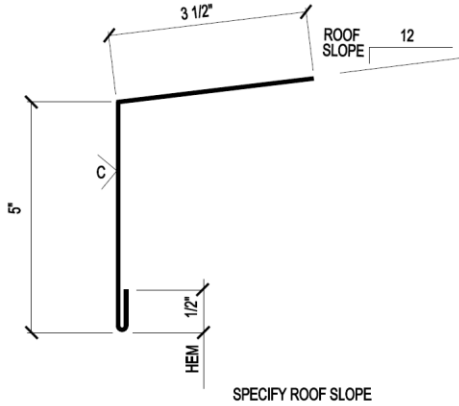

**Gutter  
FL-114**

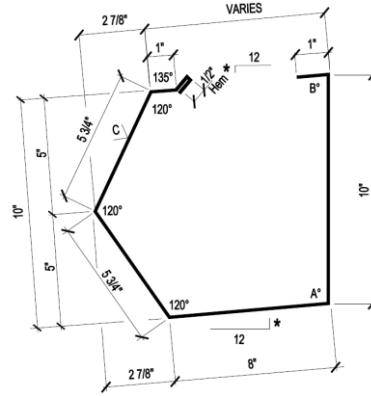

**Gutter Support  
NGC-1**

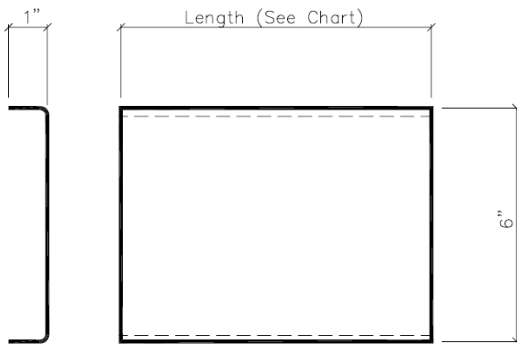

**Gutter Strap  
CC602**

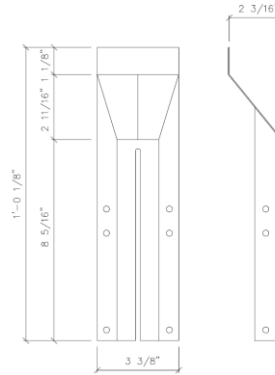

**Gutter End Cap  
FL-35L or R**

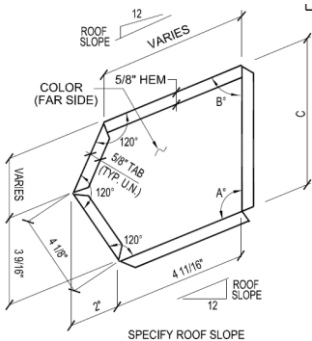

15.1 Standard Roof Line Trim Parts

Rake Trim  
FL-206

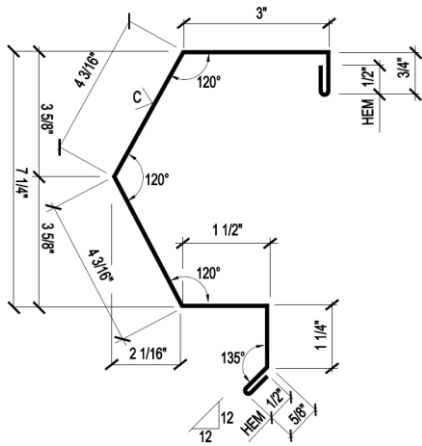

Slide Trim  
FL-207

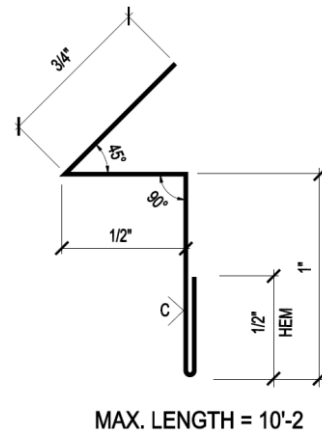

Parapet Rake Flash  
FL-224

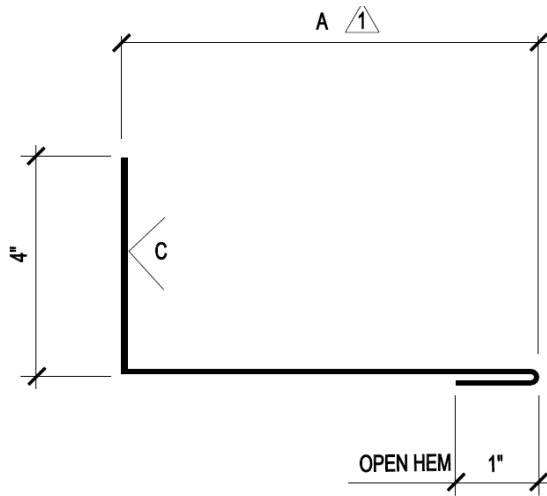

Parapet Rake Cleat  
FL-225

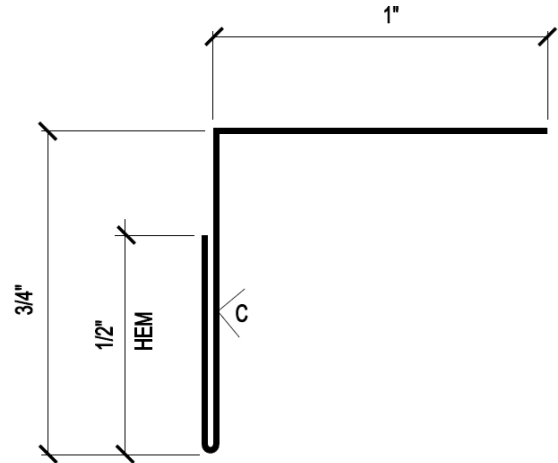

High Eave Parapet Trim  
FL-221

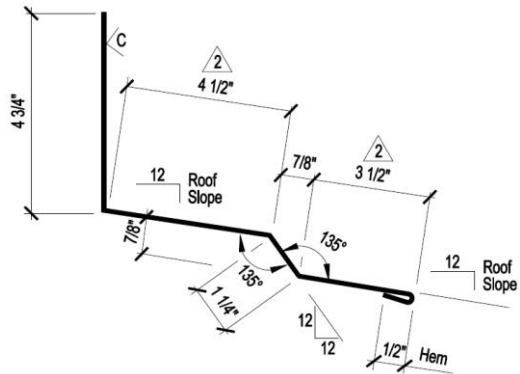



15.1 Standard Roof Line Trim Parts

Ridge Flashing  
FL-200

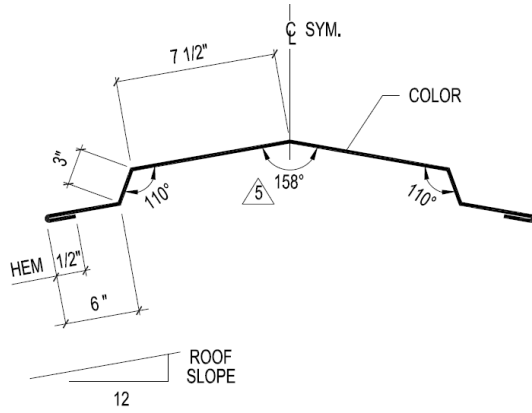

High Side Eave Trim

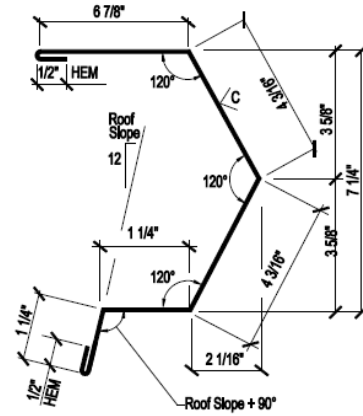

Ridge End Cap  
FL-210

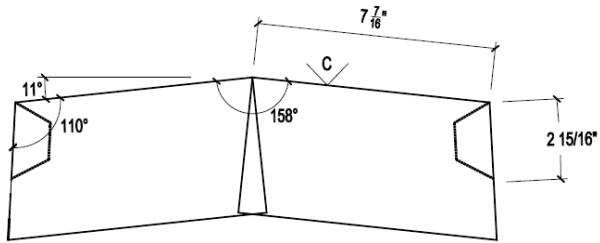

Peak Box  
FL203 A thru D

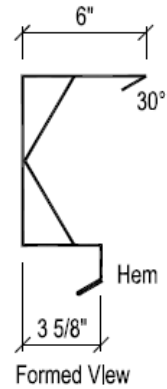

Rake End Cap  
FL-215

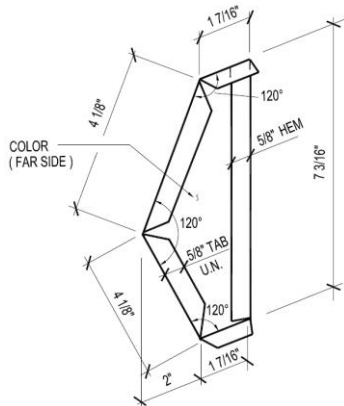

## 16.0 Roof Line Trim Installation

### 16.1 Standard Rake Trim Installation (On Module)

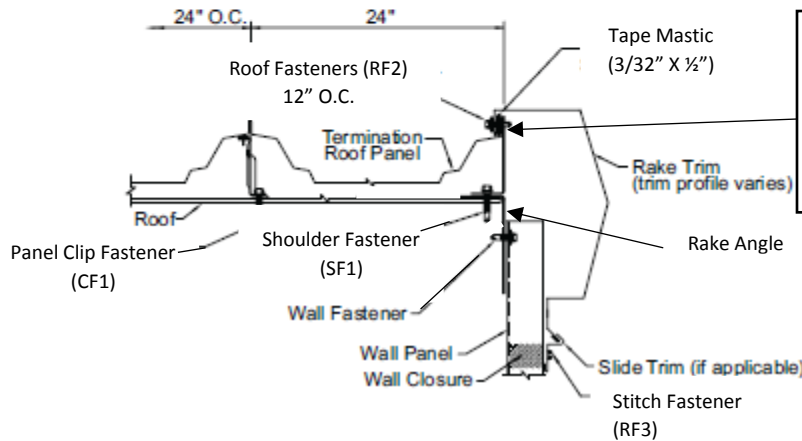
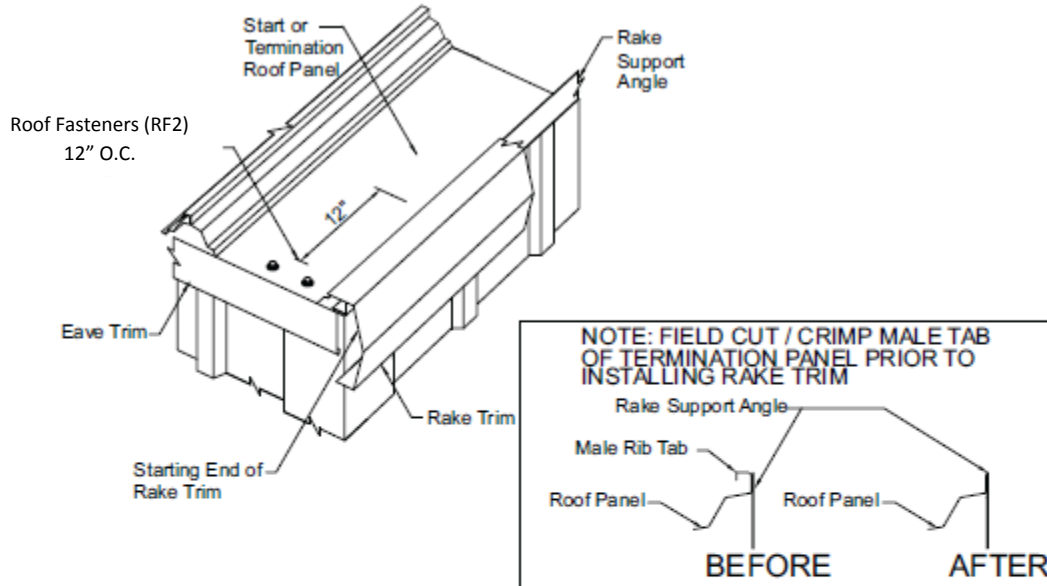

**NOTE: Confirm if your project receives a gutter or not. This will determine if the rake trim is to be started along the low edge of the panel or slid down-slope to be mitered into the gutter.**

Install the rake trim from eave to ridge to provide for watershed at the splices.

Install tape mastic 3/32" X 1/2" continuously along the vertical leg of the roof panel seam.

Check that the rake trim is properly aligned with the face of the wall panel.

Fasten the rake trim to the roof panel and rake support angle with roof fasteners (RF2) at 12-inches O.C., as shown.

Check that the fasteners penetrate the center of the tape mastic and securely engage into the rake support angle.

## 16.0 Roof Line Trim Installation

### 16.2 Standard Rake Trim Installation (Off Module)

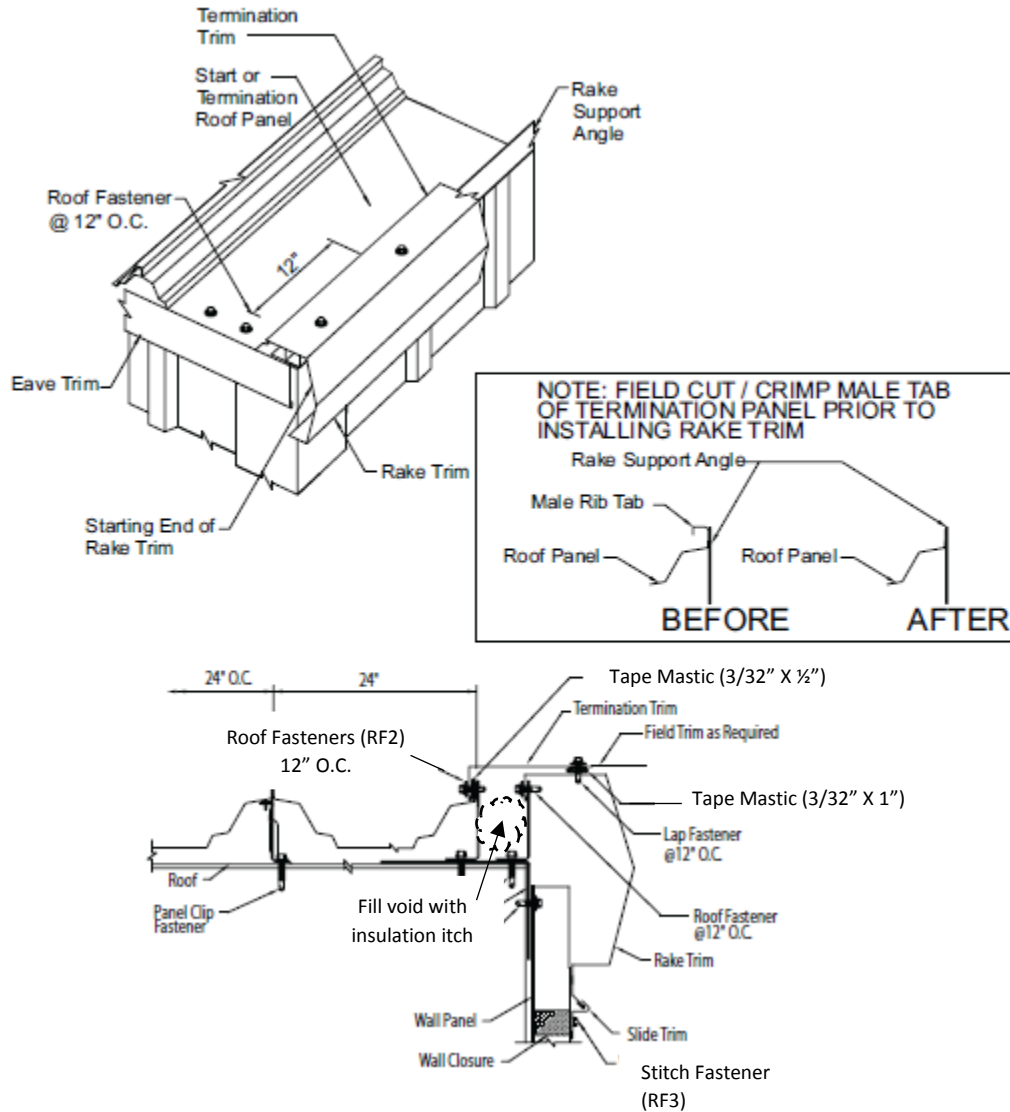

**NOTE: Confirm if your project receives a gutter or not. This will determine if the rake trim is to be started along the low edge of the panel or slid down-slope to be mitered into the gutter.**

Install the rake trim from eave to ridge to provide for watershed at the splices.

Install tape mastic 3/32" X 1/2" continuously along the vertical leg of the roof panel seam.

Check that the rake trim is properly aligned with the face of the wall panel.

Fasten the rake trim to the roof panel and rake support angle with roof fasteners (RF2) at 12-inches O.C., as shown.

Attach the termination trim, as shown, using tape mastic and fasteners.

Check that the fasteners penetrate the center of the tape mastic and securely engage into the rake support angle.

Field cut the termination trim as required at the rake.

**16.0 Roof Line Trim Installation**

**16.3 Standard Rake Trim Installation**

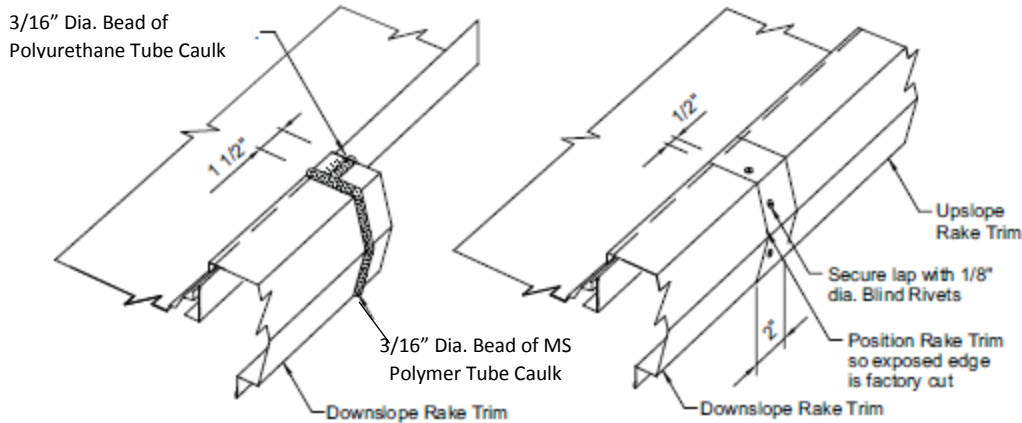

**RAKE TRIM SPLICE**

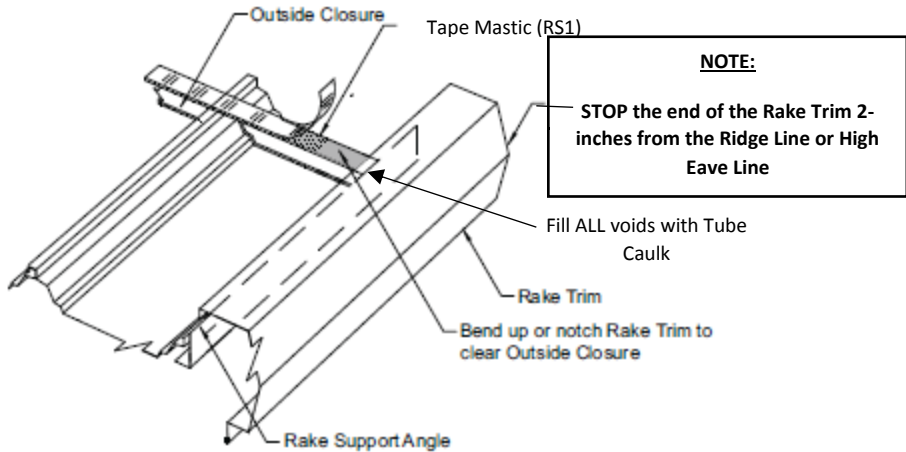

**RAKE TRIM @ RIDGE**

Assemble the rake trim splices with Polyurethane tube sealant and pop rivets as shown.

Bend or notch the rake trim's hemmed lip to clear the top flange of the outside closure. Fill any voids with MS Polymer tube sealant.

At the ridge, field cut the uphill end of the rake trim 2-inches back from the center line of the ridge or high eave to allow for thermal movement.

## 16.0 Roof Line Trim Installation

### 16.4 Standard Slide Trim Installation

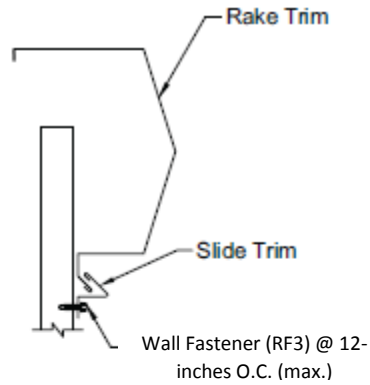

#### SLIDING ATTACHMENT

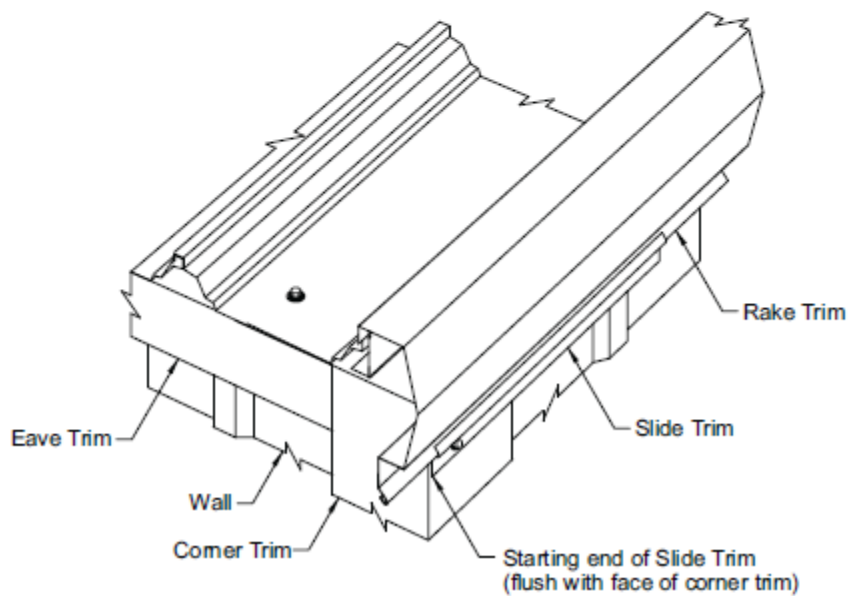

The bottom edge of the rake trim **MUST** be engaged within the slide trim to allow for roof expansion/contraction.

Install the slide trim continuous along the bottom edge of the rake trim, as shown.

In **ALL** cases, the bottom edge of the rake trim **MUST** be installed straight and parallel to the roof line. Use a chalk or string line to guide the alignment of the rake trim's bottom edge.

## 16.0 Roof Line Trim Installation

### 16.5 Standard Peak Box Installation

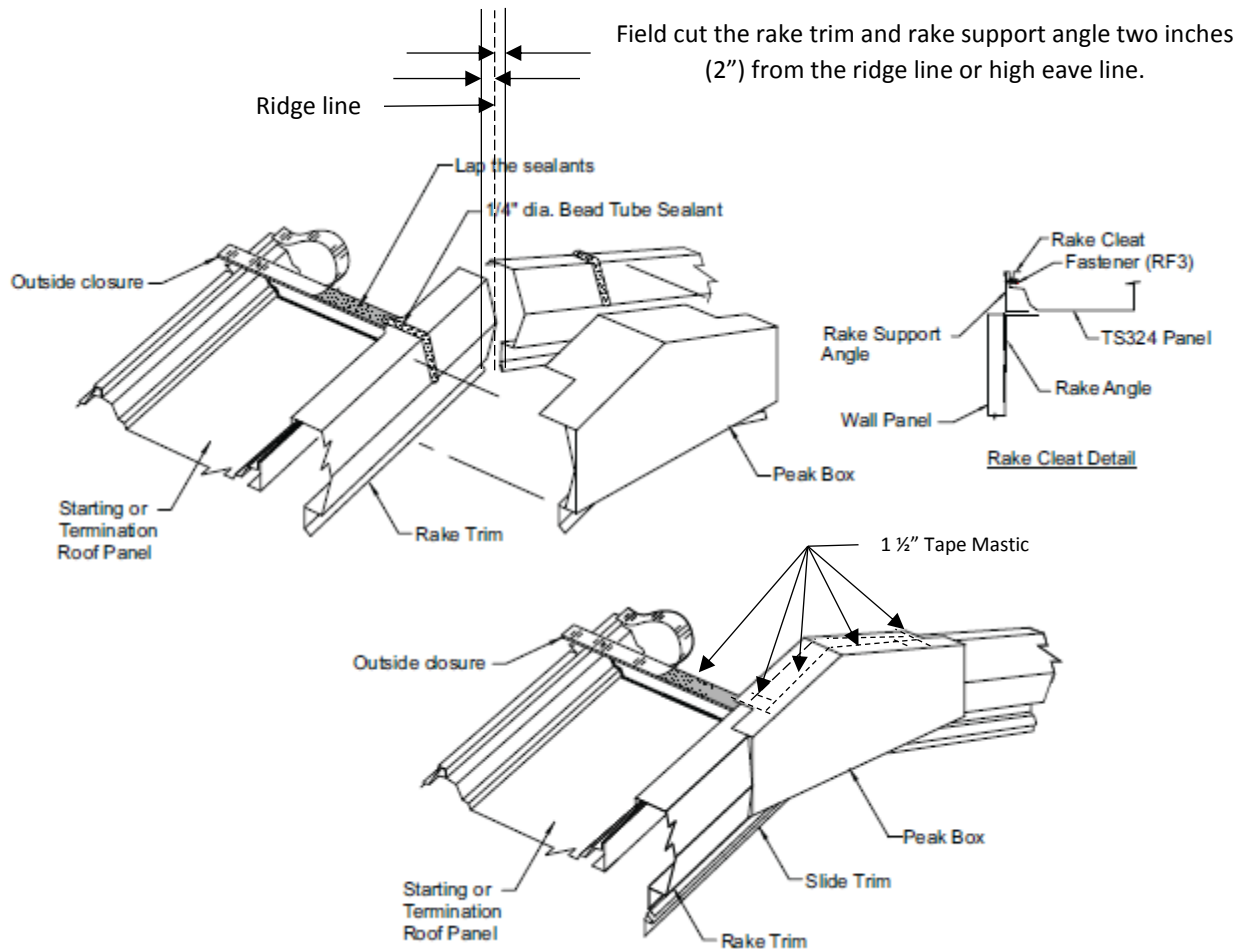

Apply a continuous bead of MS Polymer tube caulk on the underside of the peak box where it comes in contact with the rake trims. Apply MS Polymer tube caulk to any gaps on the underside of the peak box in the mitered area.

Center the prepared peak box over the ridge. Once centered, push the peak box down and over the rake trims. Make sure the back lip of the peak box is between the outside closures and the rake trim. Insure that there is a 2-inch space between the lip of the peak box and the closures to allow for thermal movement. Finish installing the slide trim over the bottom of the peak box.

Install a continuous 1 1/2" tape mastic along the top of the outside closures on both sides of the ridge. Remove the paper backing ONLY as work progresses.

After the peak box is in place, extend the 1 1/2" tape mastic from the outside closures to the sloped face to the rake trim. Next, install short pieces of 1 1/2" tape mastic to the flat portion of the ridge cap.

**DO NOT PLACE ANY FASTENERS IN THE PEAK BOX.** Doing so will not allow the rake trim to "float" with the expansion and contraction of the roof system.

**FIELD CUT THE RAKE TRIM TWO INCHES (2") FROM THE RIDGE LINE OR HIGH EAVE LINE TO ALLOW FOR THERMAL MOVEMENT.**

## 16.0 Roof Line Trim Installation

### 16.5 Standard Peak Box Installation

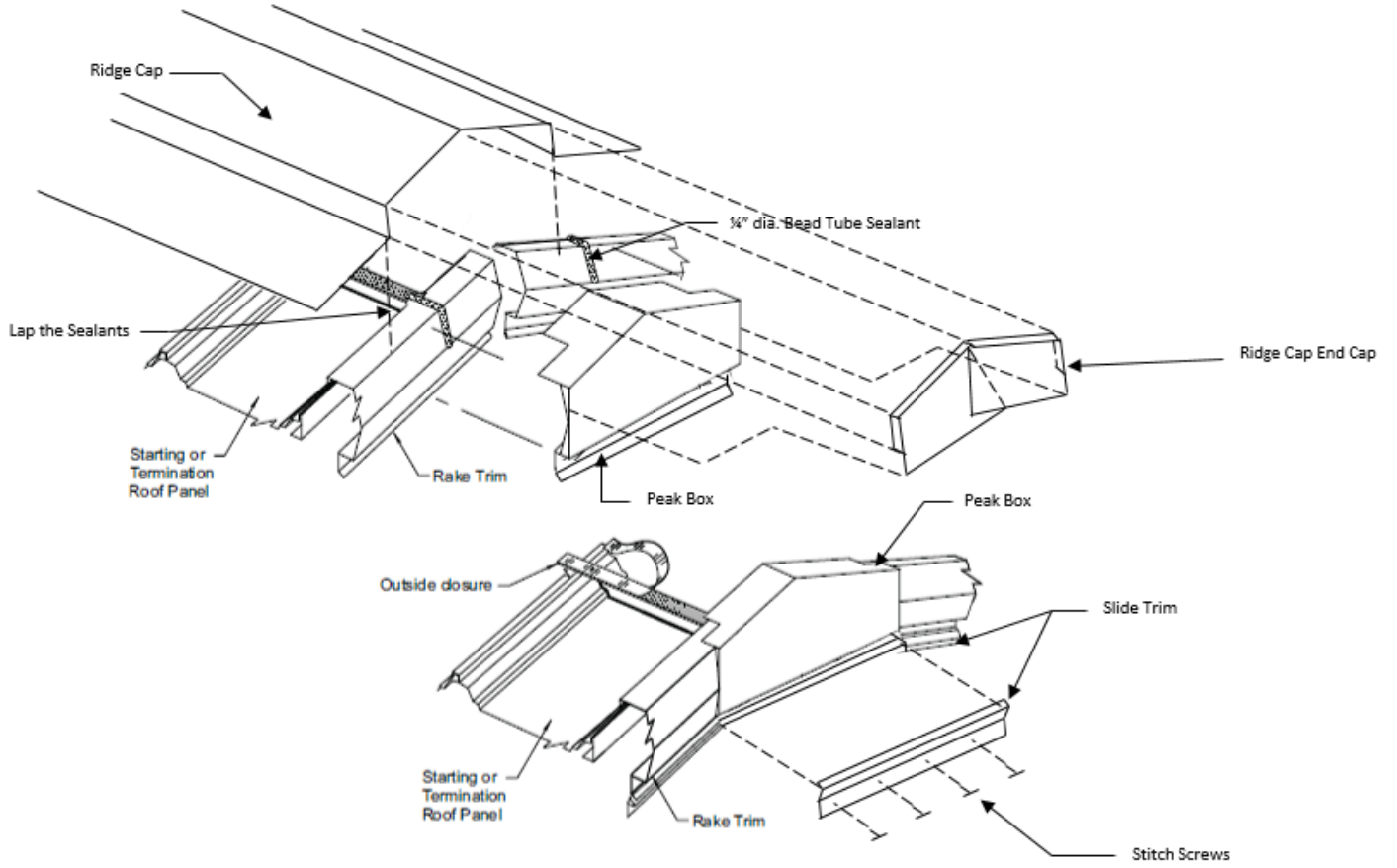

## 16.0 Roof Line Trim Installation

### 16.6 Standard Ridge Cap Installation

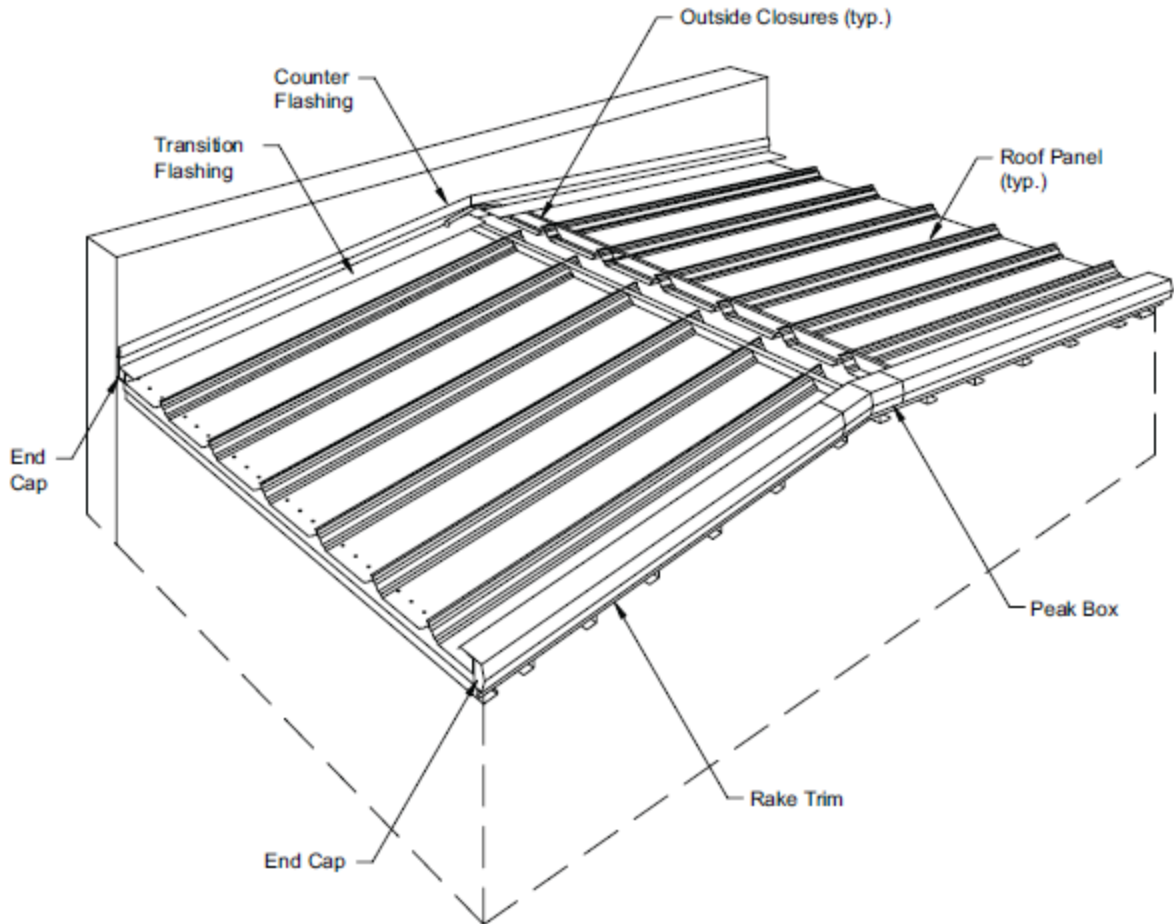

Note: Parapets or existing buildings should extend 1'-0" minimum above roof panels.

The details in this section show the installation of the ridge cap. The ridge cap can be started or finished at either a rake trim condition or a rake parapet transition condition.



## 16.0 Roof Line Trim Installation

### 16.7 Standard Ridge Cap Tape Mastic Installation

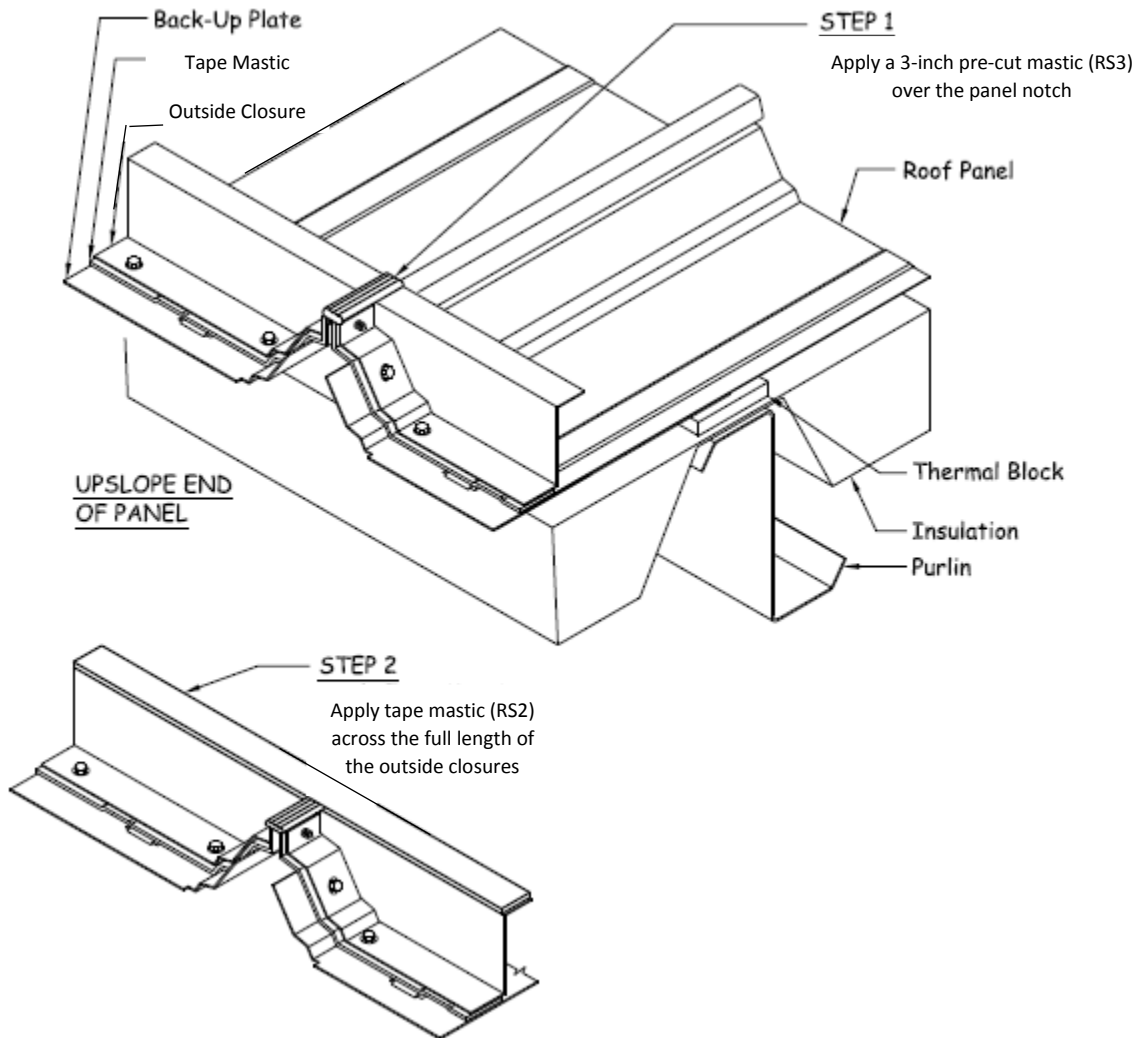

**Before installing the sculptured high eave trim, high eave parapet trim, or ridge cap, apply a piece of 3-inch pre-cut tape mastic (RS3) as shown in the detail below.**

Apply this pre-cut tape mastic (RS3) to the full length of the panel notch and where the outside closures are butted together at the panel seam. (FILL any gaps where the closures attach to the roof panel.)

Apply the 1 ½-inch tape mastic (RS1) continuously across the top of the closures full length of the roof (peeling back the protective paper ONLY as work progresses).

16.0 Roof Line Trim Installation

16.8 Standard Ridge Cap and End Cap Installation

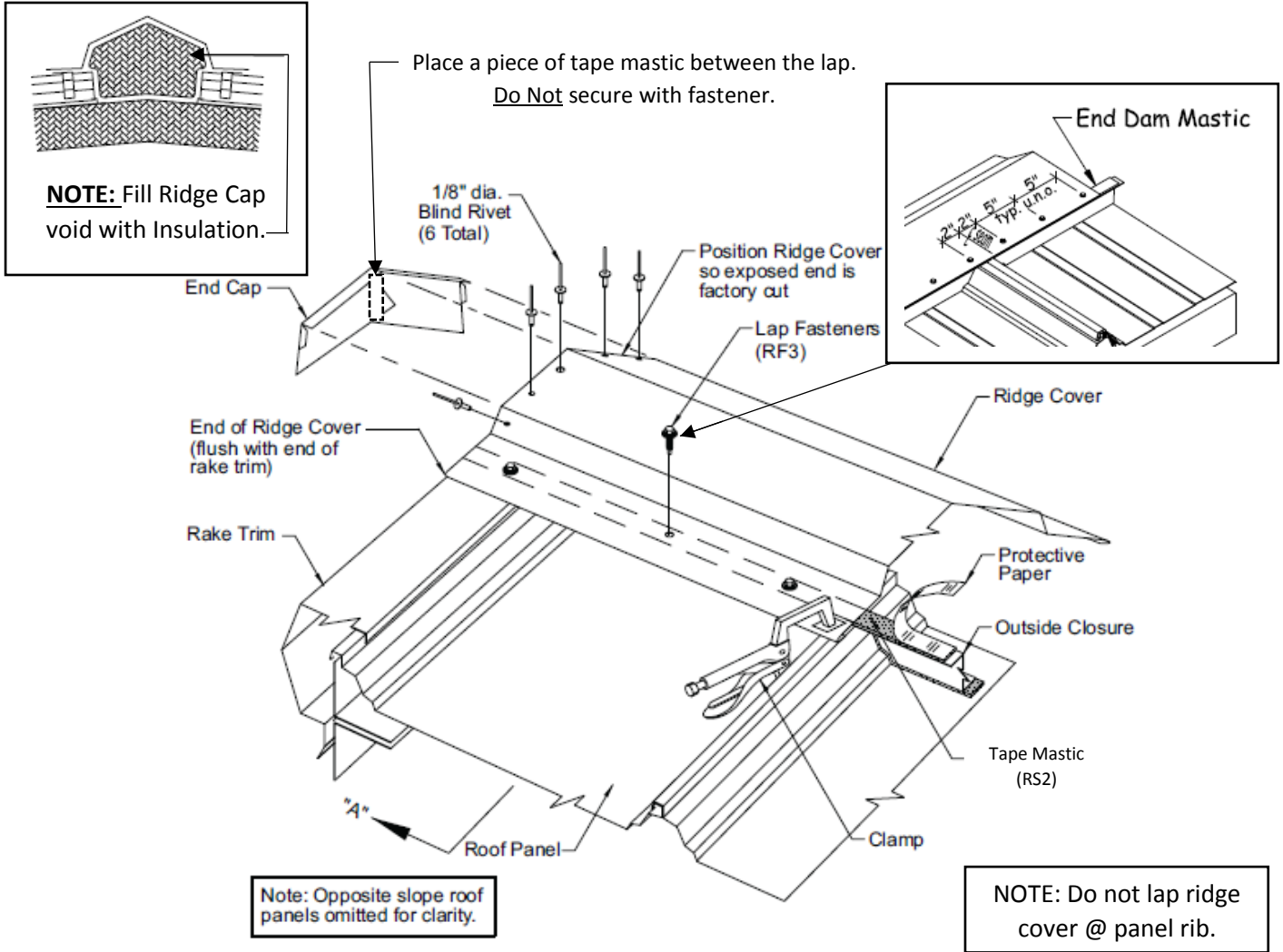

Install the ridge cap to span equally across the opposing outside closures.

Position the end of the ridge cap flush with the sloped edge of the rake trim.

**FILL THE RIDGE CAP CAVITY WITH INSULATION ITCH FOR CONDENSATION PREVENTION.**

Align the center of the ridge cap over the ridge centerline. Use a string line to assure a straight ridge cap installation.

The ridge cap **MUST** be properly positioned before touching the tape mastic. **Mastic cannot be reused.**

Fasten the ridge cover to the outside closures with (5) ridge cap colored fasteners (RF3) per panel width. (2" from the center of each panel rib and 5" O.C. in between).

Install the first fastener greater than 1 1/2" from the end of the ridge cap (inside the notched out area of the peak box. **DO NOT PLACE ANY FASTENERS INTO THE PEAK BOX TO ALLOW FOT THERMAL MOVEMENT.**

Check that the fasteners penetrate the center of the outside closure's top flange and its tape mastic.

Install the end cap into the end of the ridge cap, as shown. See additional details on next page.

16.0 Roof Line Trim Installation

16.8 Standard Ridge Cap and End Cap Installation

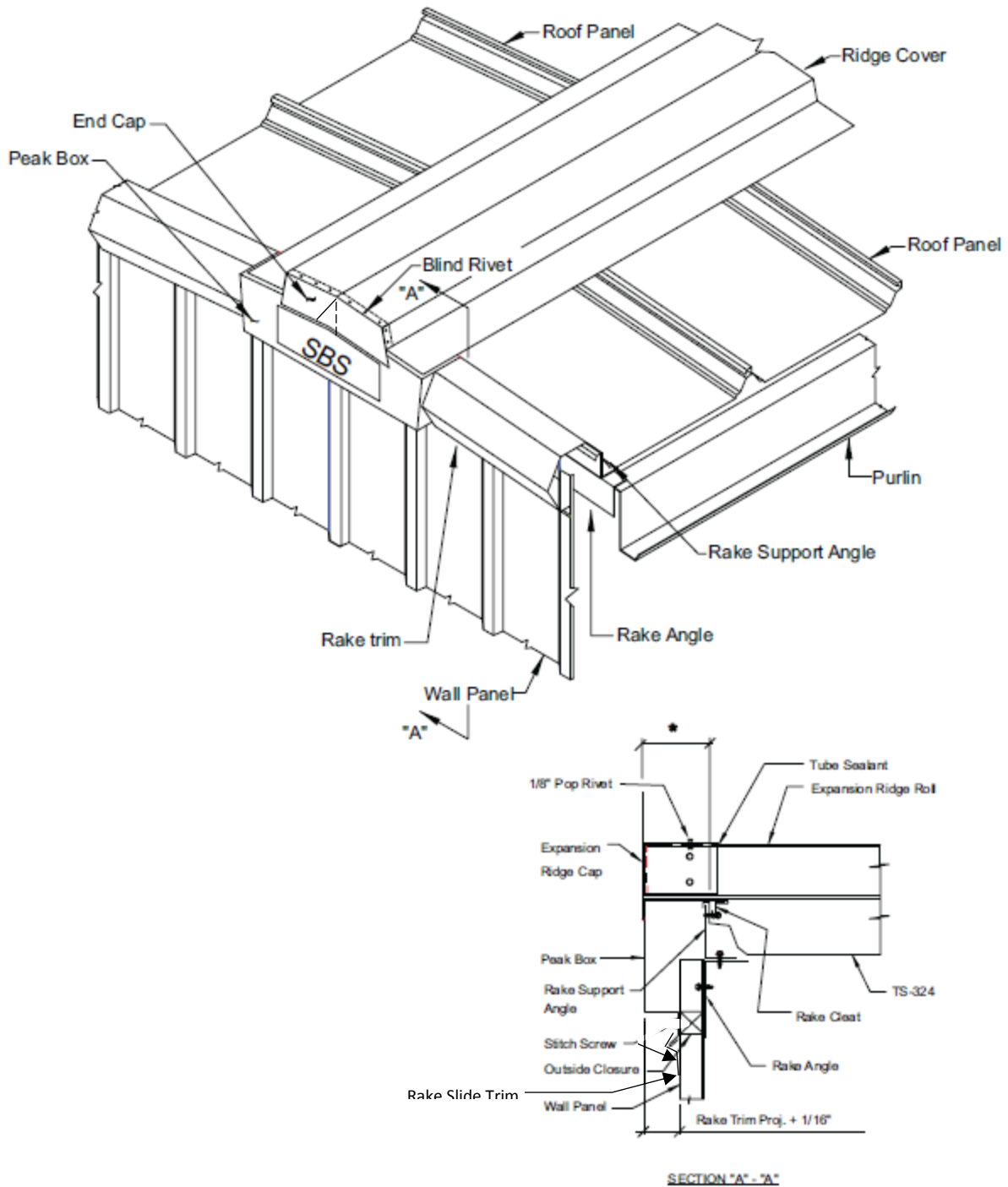

**16.0 Roof Line Trim Installation**

**16.9 Standard Ridge Cap Lap Installation**

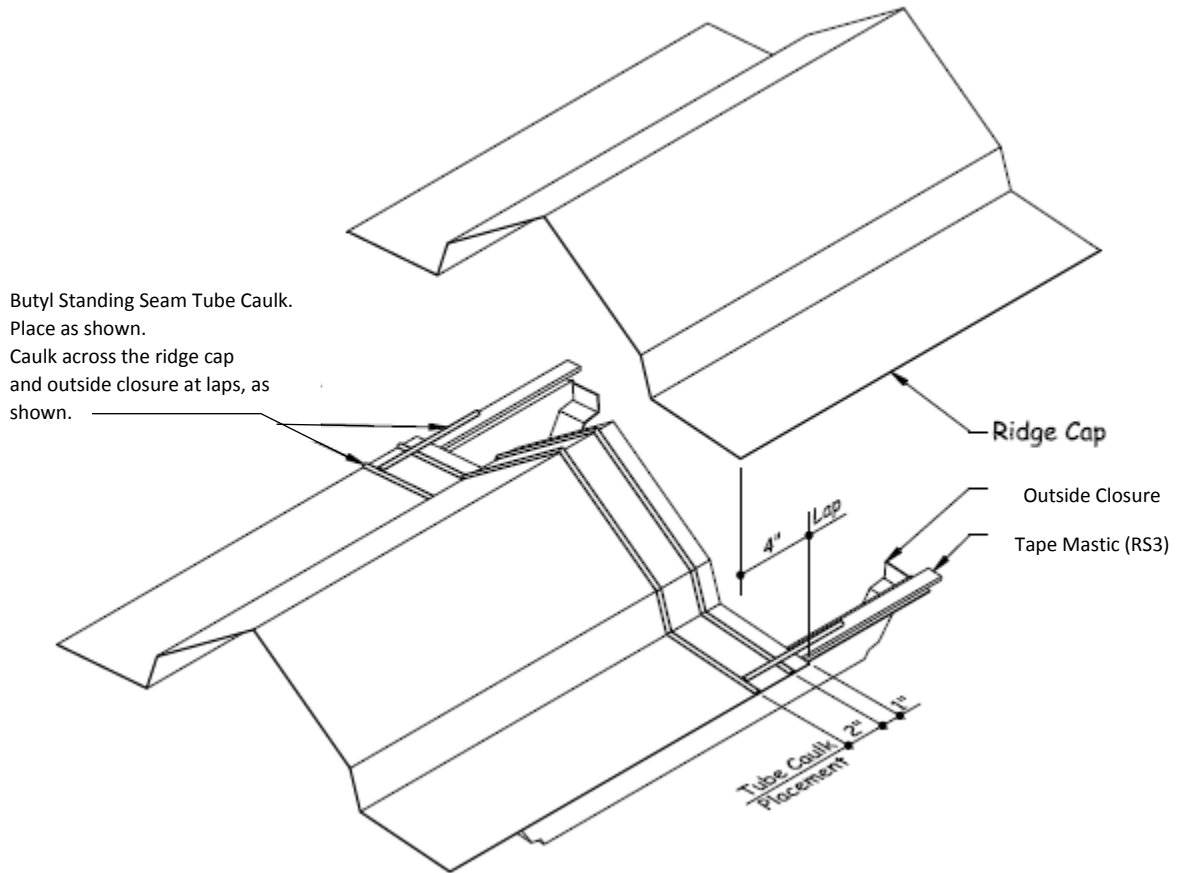

**IMPORTANT NOTE: DO NOT LAP THE RIDGE CAP AT A PANEL RIB.**

**DO NOT USE FASTENERS AT THE RIDGE CAP LAPS. DOING SO WILL NOT ALLOW FOR LONGITUDINAL MOVEMENT ALONG THE RIDGE CAP AS IT IS DESIGNED.**

The ridge cap is to be lapped 4-inches, utilizing (2) beads of Butyl standing seam tube caulk.

Also apply the tube caulk to the tape mastic as shown.

Tips to strengthen the large planes of the ridge cap, use a 4" wide vise clamp and form a short leg stiffener on the larger elevation ridge cap only.

Fold the material downwards to a 90°. Tap the back of the fold with a hammer to form a sharp 90° bend.

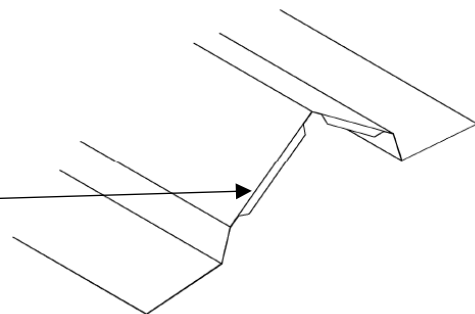

## 16.0 Roof Line Trim Installation

### 16.10 Standard Rake Trim End Cap Installation

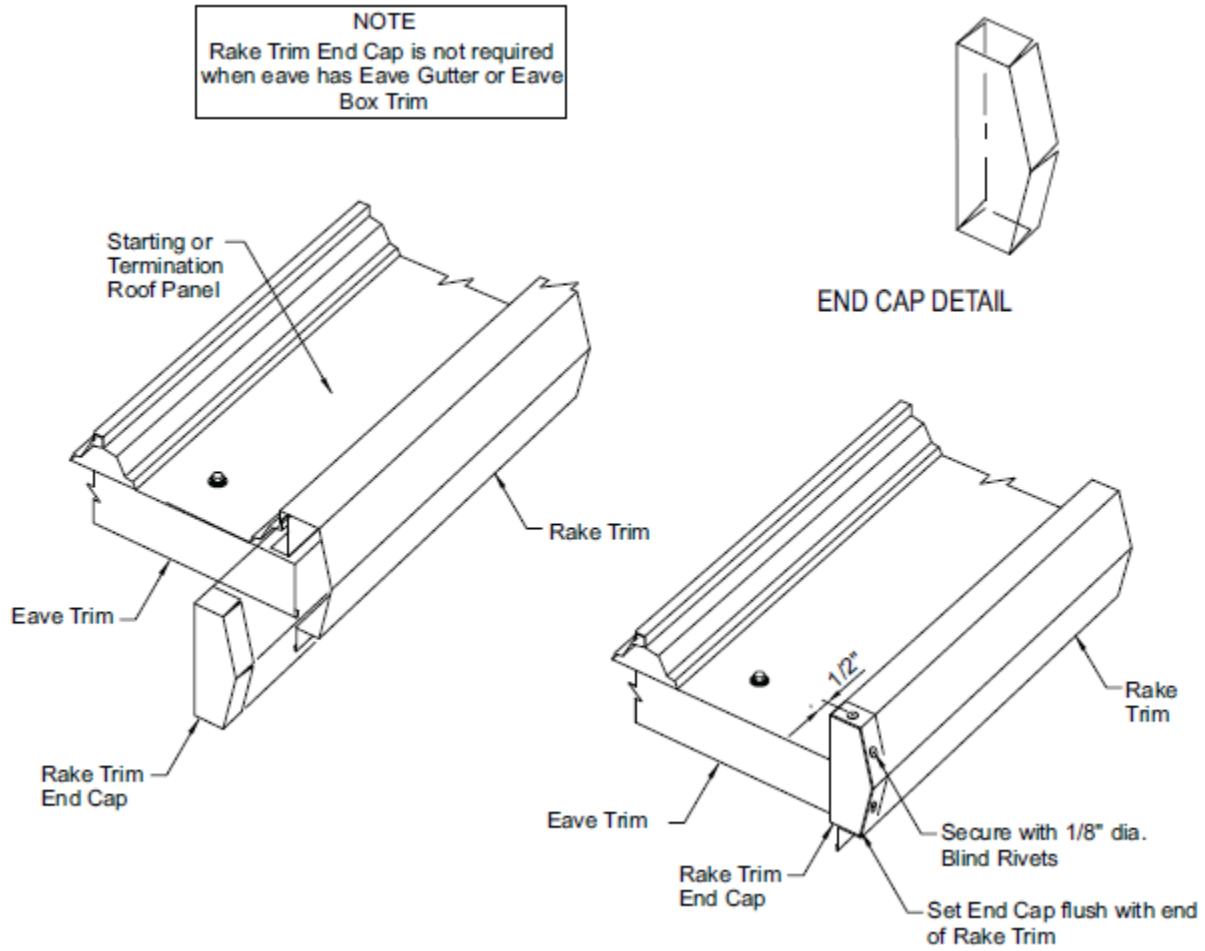

The rake trim end cap is only required for roof applications without eave gutter.

Install the end caps with tube sealant and pop rivets in the same manner as a splice.

## 16.0 Roof Line Trim Installation

### 16.11 Standard Rake Parapet Transition Flashing Installation

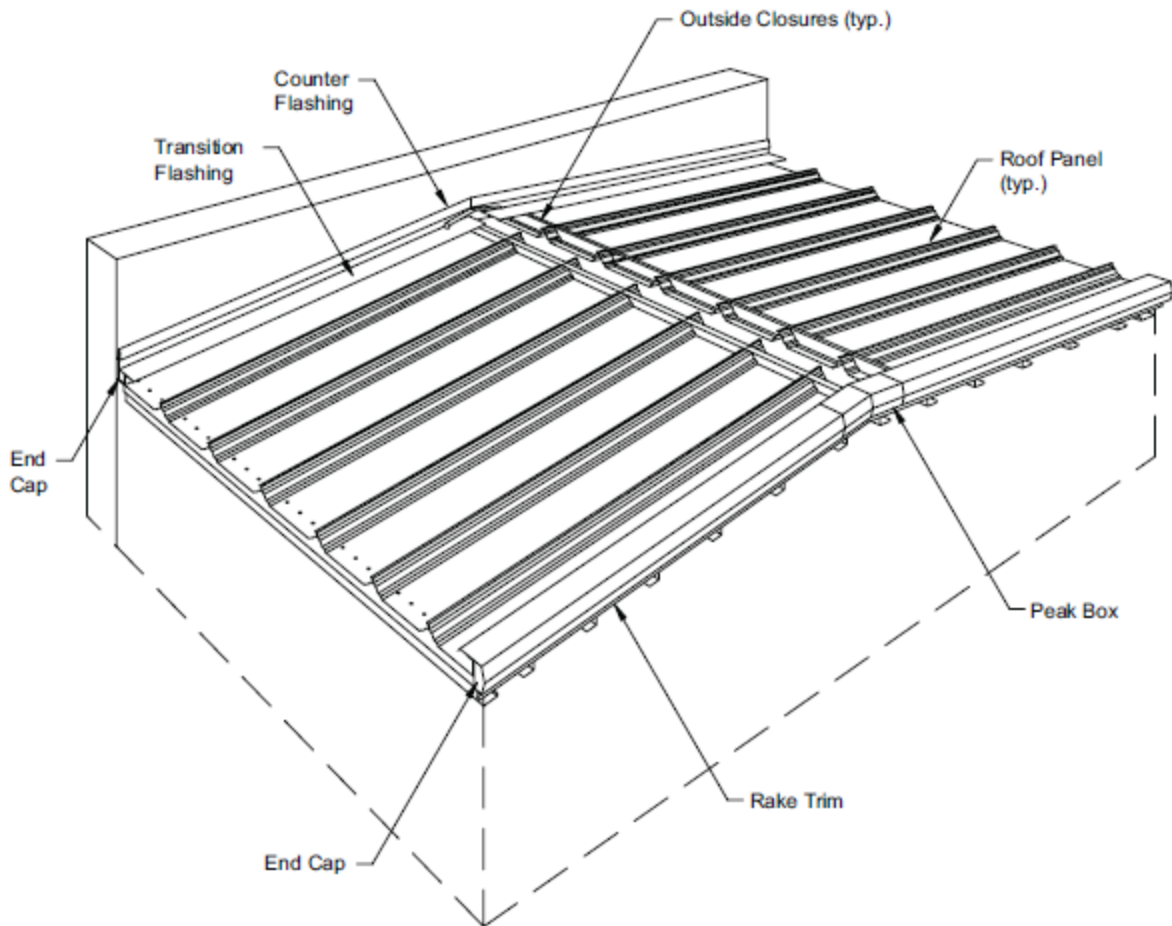

Note: Parapets or existing buildings should extend 1'-0" minimum above roof panels.

The details in this section show the installation of the rake parapet transition flashing.

Counter-flashing details are not shown.

In all cases, verify that the counter-flashing will:

1. Allow for thermal expansion/contraction of the transition flashing.
2. Restrain the transition flashing during roof live loads and wind loads.
3. Provide a weather tightness seal between the transition flashing and the wall.

## 16.0 Roof Line Trim Installation

### 16.11 Standard Rake Parapet Transition Flashing Installation (w/Rake Angle Cleat)

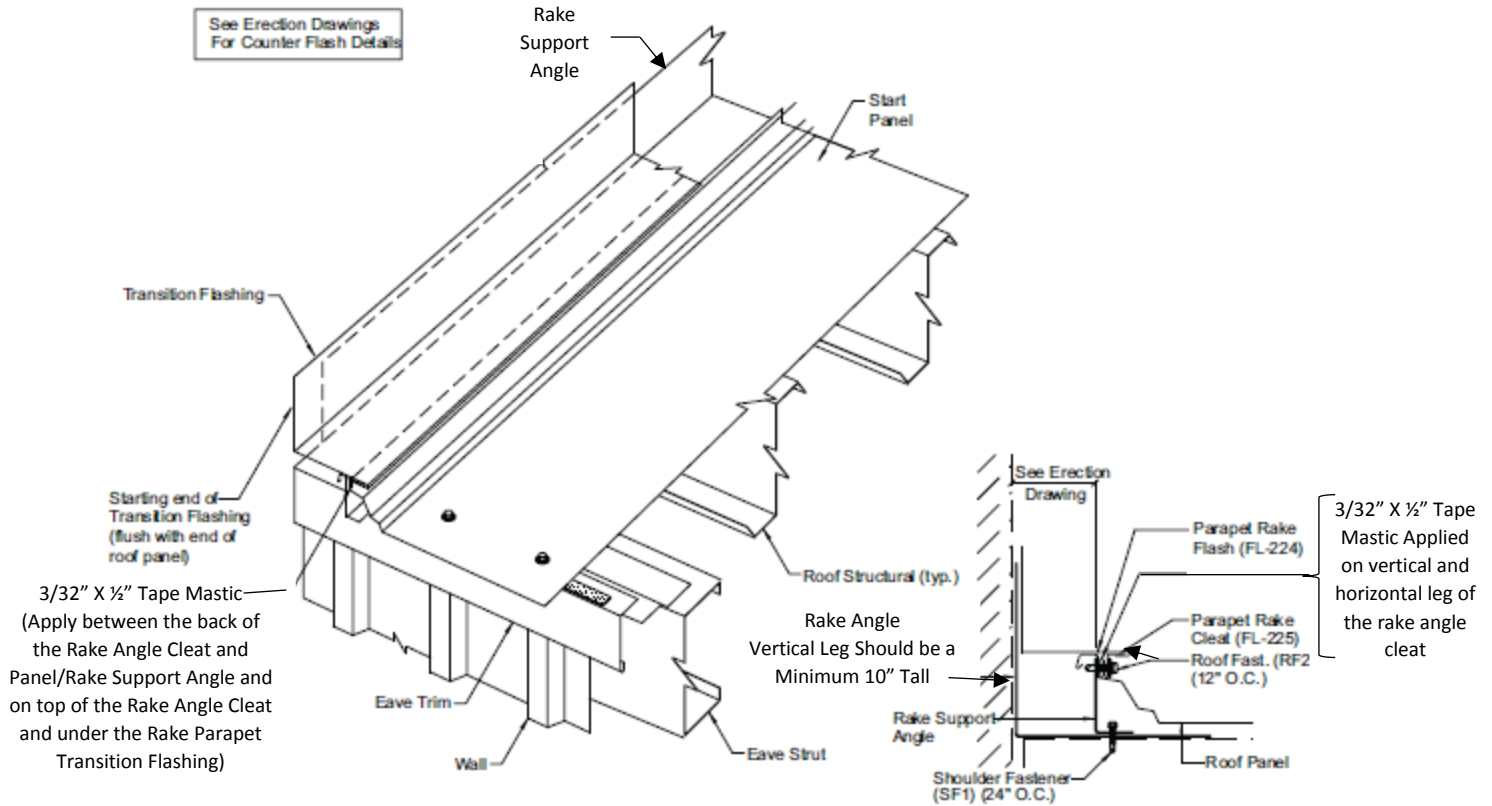

Install the rake parapet transition flashing from eave to ridge to provide for watershed at the splices.

Check that the flashing is set at a positive pitch to assure a watershed affect.

Apply tape mastic (3/32" X 1/2") between the panel and back of the rake angle cleat.

Slide the flashing's folded edge over the rake cleat.

Apply tape mastic (3/32" X 1/2") on top of the rake angle cleat between the rake parapet transition flashing and top of the rake angle cleat.

Check that the fasteners penetrate the center of the tape mastic and legs of the rake angle cleat and are fully engaged.

Start the down-slope end of the flashing flush with the end of the roof panel and position the back leg flush with the rake angle or wall construction.

## 16.0 Roof Line Trim Installation

### 16.11 Standard Rake Parapet Transition Flashing Installation (w/o Rake Angle Cleat)

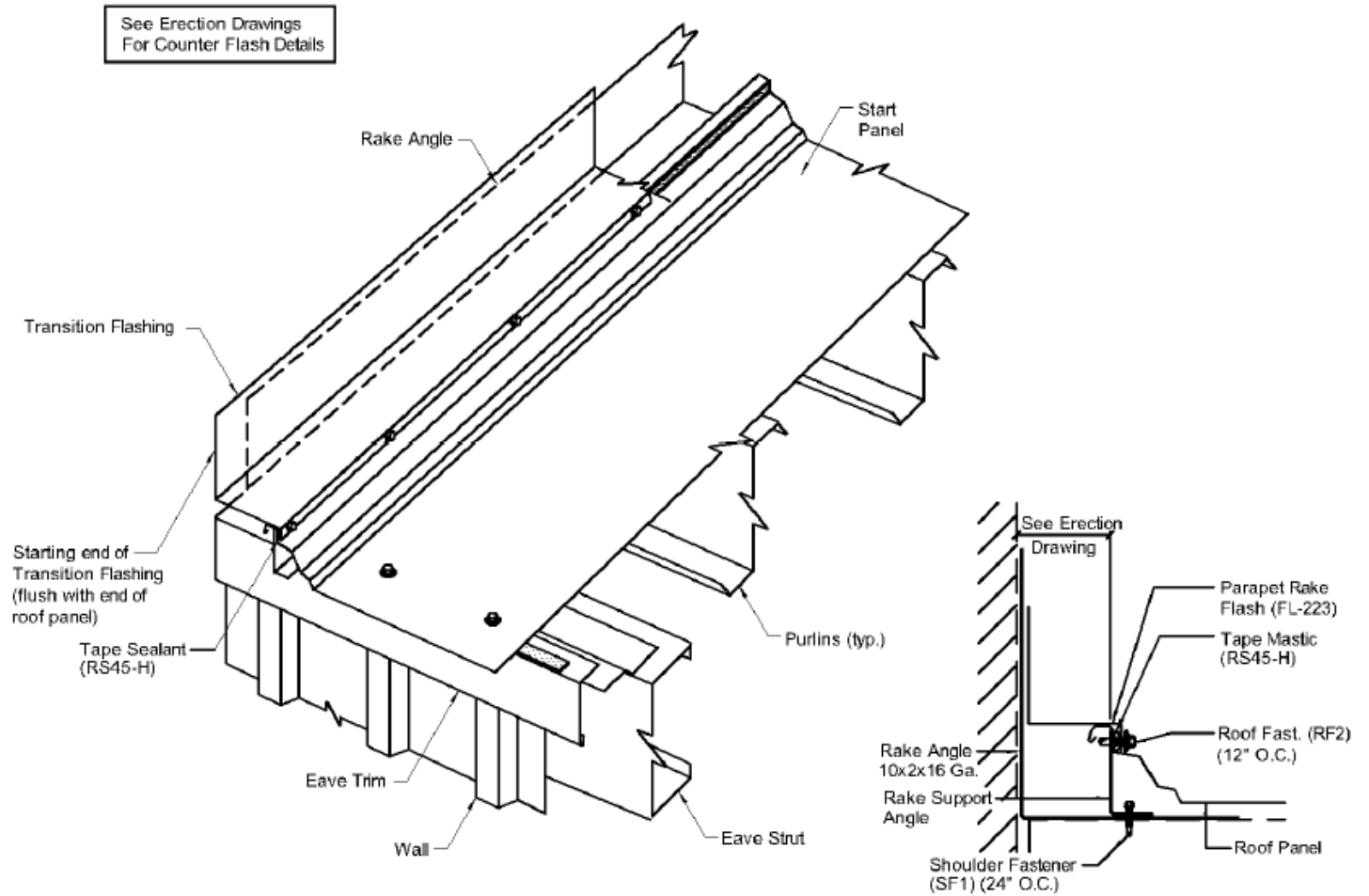



16.0 Roof Line Trim Installation

16.12 Standard Rake Parapet Transition Flashing Installation Details (w/Rake Angle Cleat)

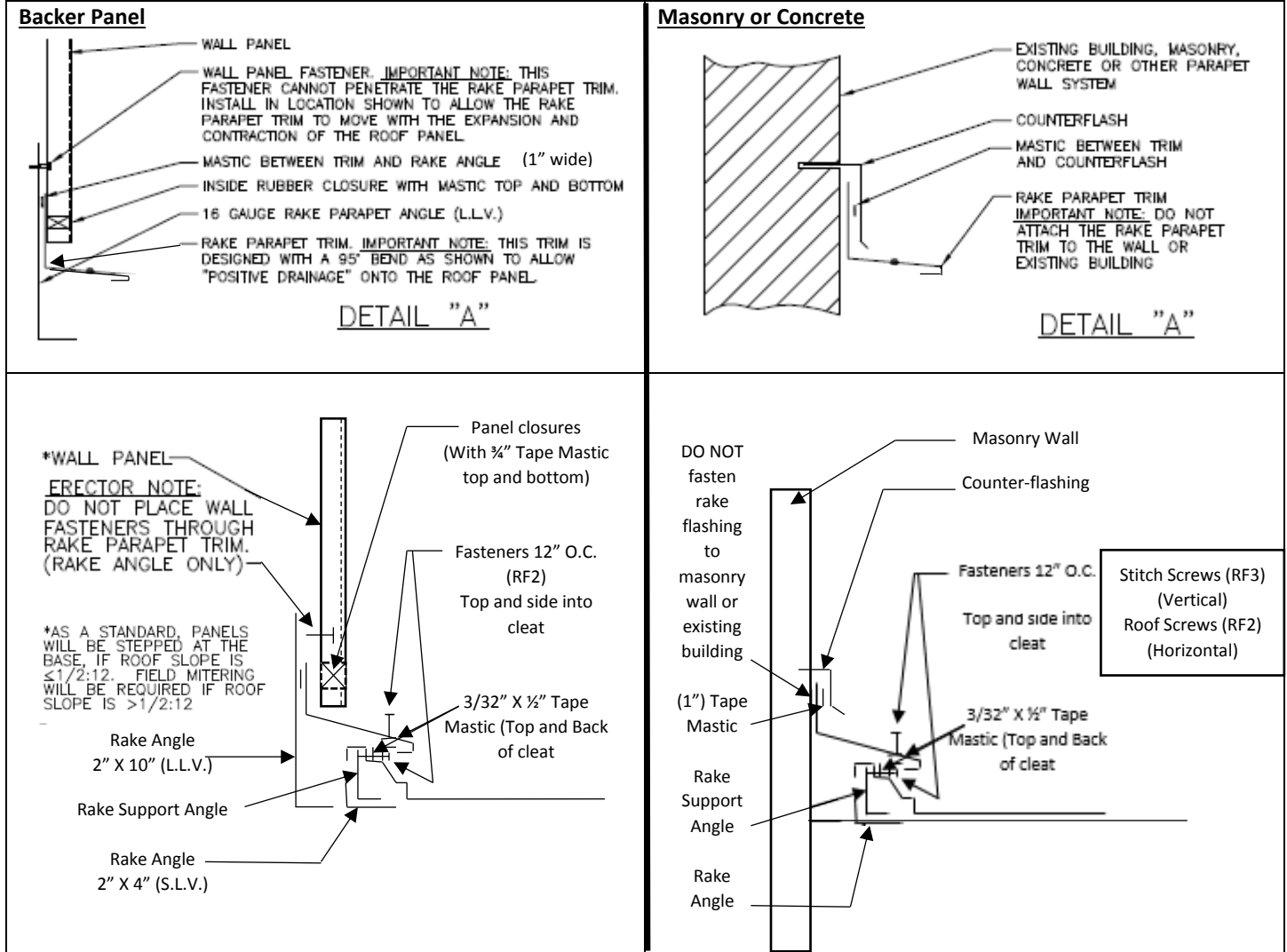

## 16.0 Roof Line Trim Installation

### 16.12 Standard Rake Parapet Transition Flashing Installation Details (w/o Rake Angle Cleat)

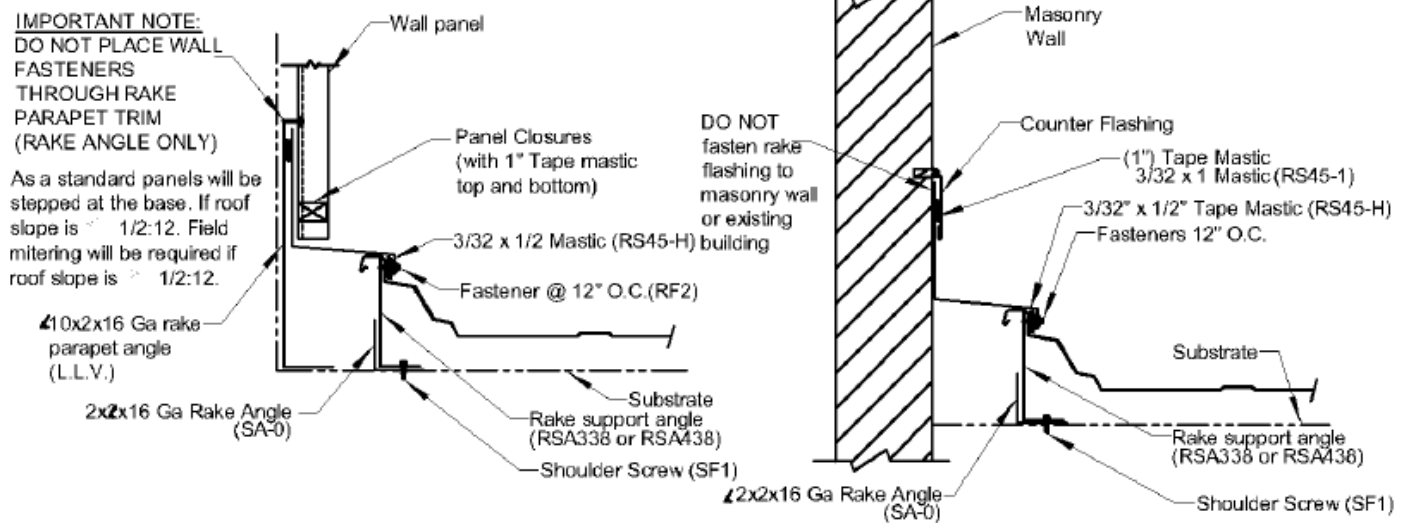
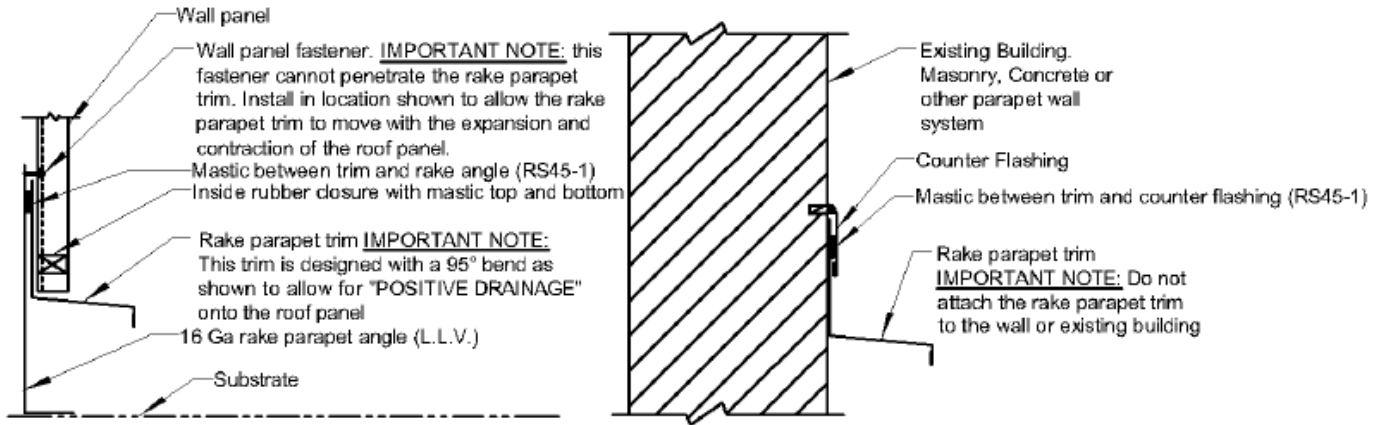

**16.0 Roof Line Trim Installation**

**16.13 Standard Rake Parapet Transition Flashing Lap Installation (w/Rake Angle Cleat)**

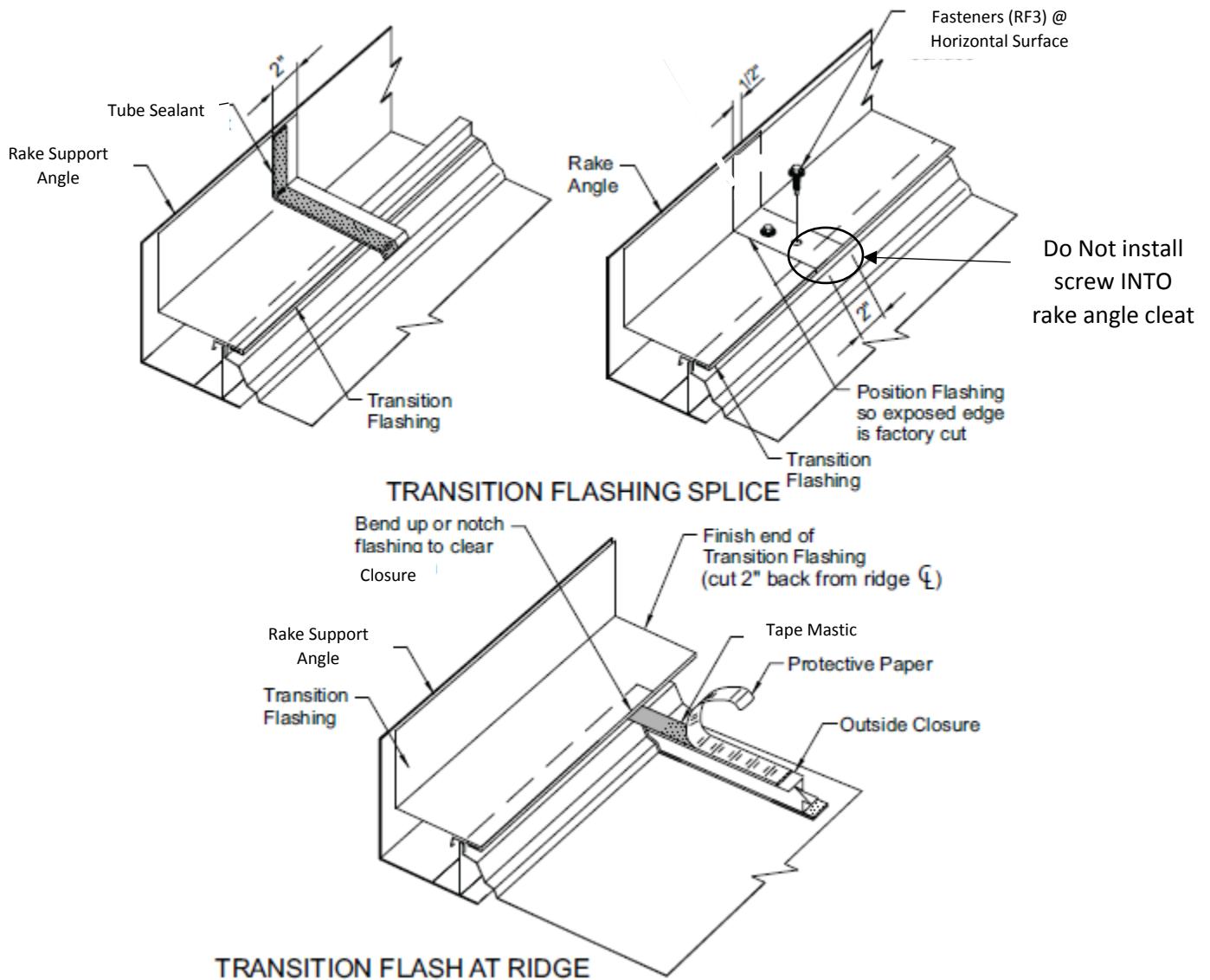

Assemble the transition flashing laps with Polyurethane tube sealant and stitch screws (RF3) as shown. Wipe dry and clean the lapping surfaces of the flashing.

Bend or notch the flashing's lip to clear the top flange of the outside closure.

At the ridge, field cut the end of the flashing 2-inches away from the center line of the ridge to allow for thermal movement

At a high eave transition, field cut the end of the flashing as required for a weather tight joint with the adjacent construction.

16.0 Roof Line Trim Installation

16.13 Standard Rake Parapet Transition Flashing Lap Installation (w/o Rake Angle Cleat)

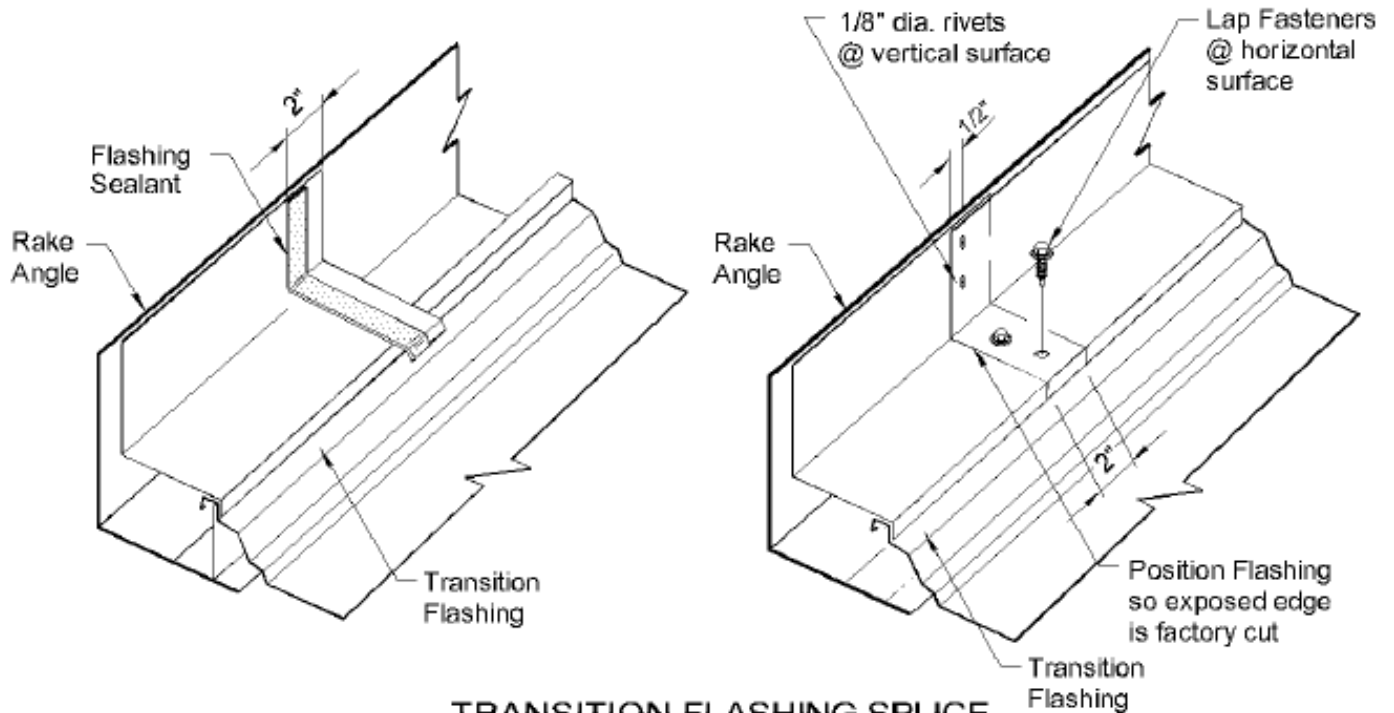

TRANSITION FLASHING SPLICE

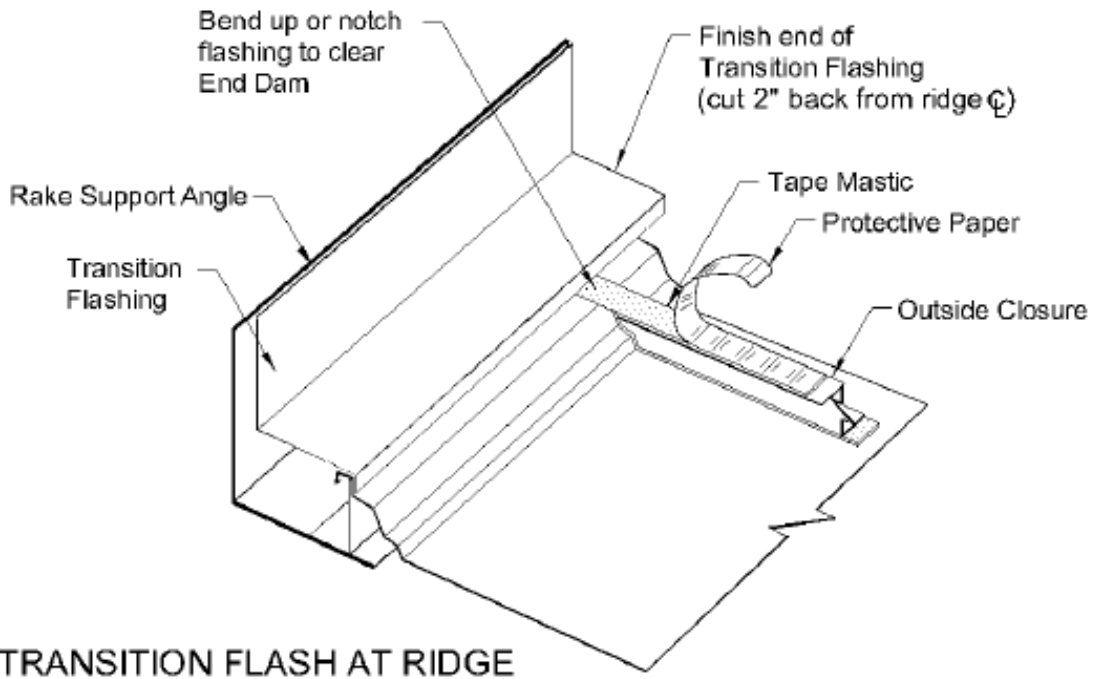

TRANSITION FLASH AT RIDGE

## 16.0 Roof Line Trim Installation

### 16.14 Standard Rake Parapet Transition Flashing and Ridge Cap Installation

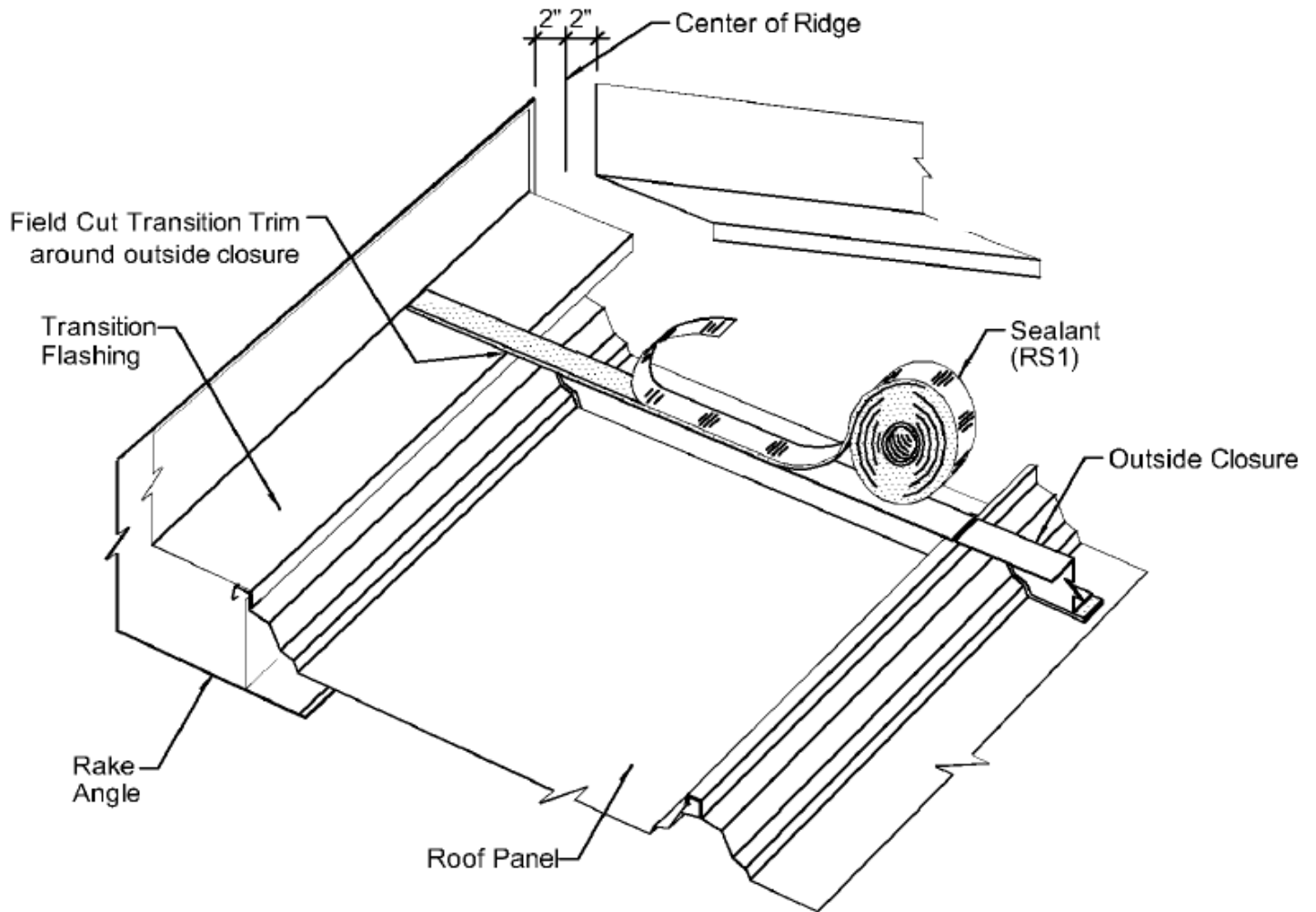

Note: Opposite slope roof panels omitted for clarity.

Position the edge of the tape mastic (RS1) flush against the face of the transition flashing and extend the ends of the tape mastic to align with the outside closures.

Install the tape mastic (RS1) continuous along the top flange of the outside closures.

## 16.0 Roof Line Trim Installation

### 16.14 Standard Rake Parapet Transition Flashing and Ridge Cap Installation

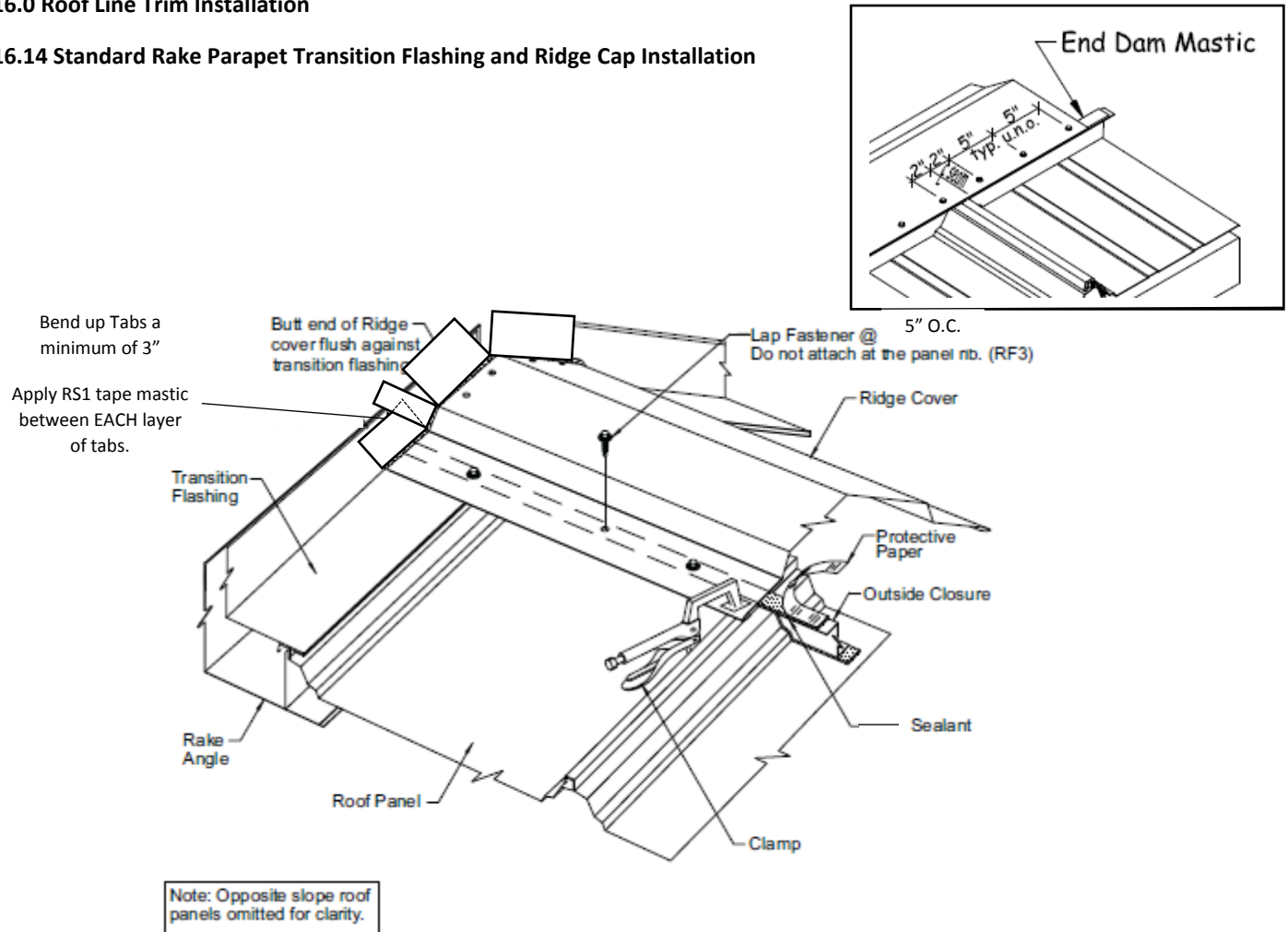

Cut each plane of the ridge cap and fold it upwards a **minimum** of 3-inches. This is required to extend behind counter flashing or backer panels for thermal movement and weather tightness. (The ridge top point can raise 3-inches during expansion on a large roof plane.)

Apply tape mastic (RS1) between EACH layer of the tabs.

Install the ridge cap to span equally across the opposing outside closures.

Position the end of the ridge cap flush with the sloped edge of the rake trim.

**FILL THE RIDGE CAP CAVITY WITH INSULATION ITCH.**

Align the center of the ridge cap over the ridge centerline. Use a string line to assure a straight ridge cap installation.

The ridge cap **MUST** be properly positioned before touching the tape mastic. **Mastic cannot be reused.**

Fasten the ridge cover to the outside closures with (5) ridge cap colored fasteners (RF3) per panel width. (2" from the center of each panel rib and 5" O.C. in between).

Check that the fasteners penetrate the center of the outside closure's top flange and its tape mastic.

## 16.0 Roof Line Trim Installation

### 16.14 Standard Rake Parapet Transition Flashing and Ridge Cap Installation

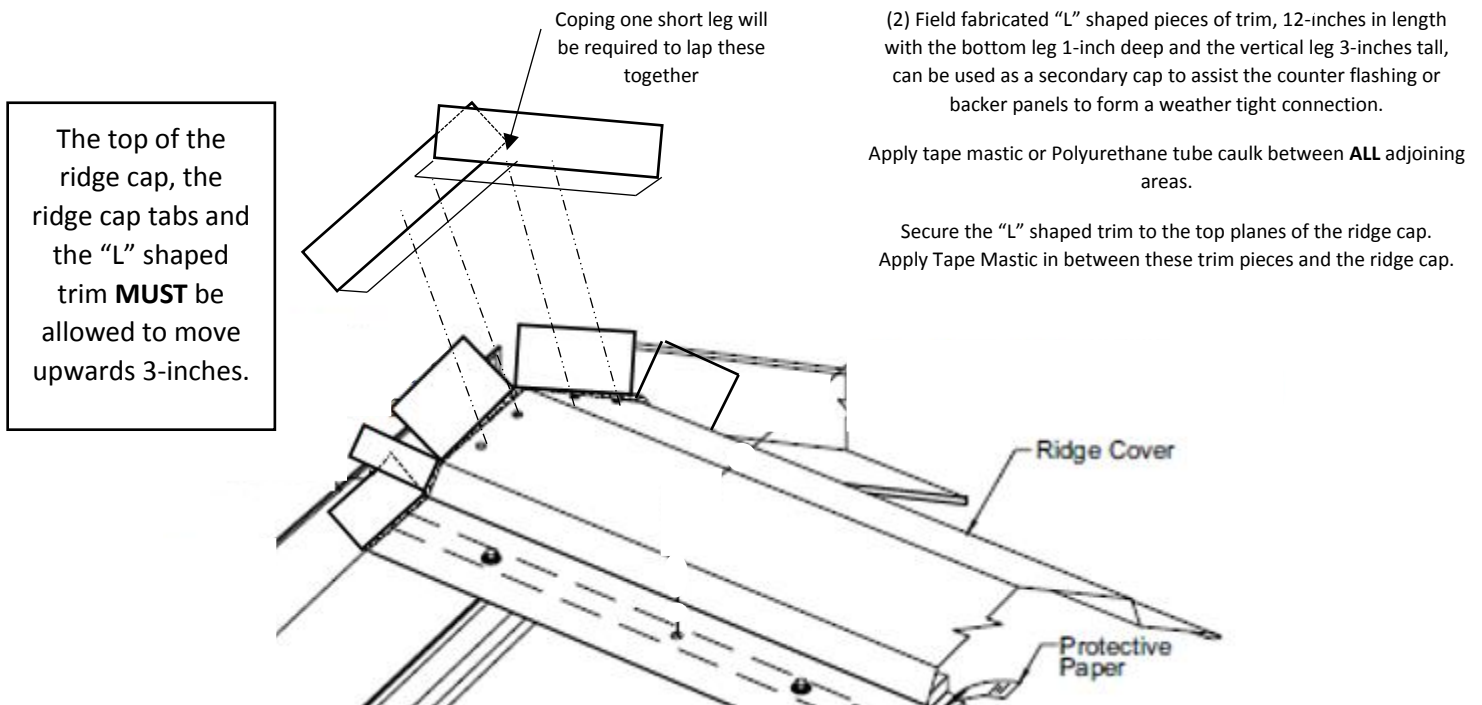

Jamb trim can trim out the backer panel cut-out

(**MUST** be installed at an elevation which will allow for thermal upwards movement of the ridge cap.)

## 16.0 Roof Line Trim Installation

### 16.15 Standard Rake Parapet Transition Flashing to High Eave Trim Installation (Inside Corner)

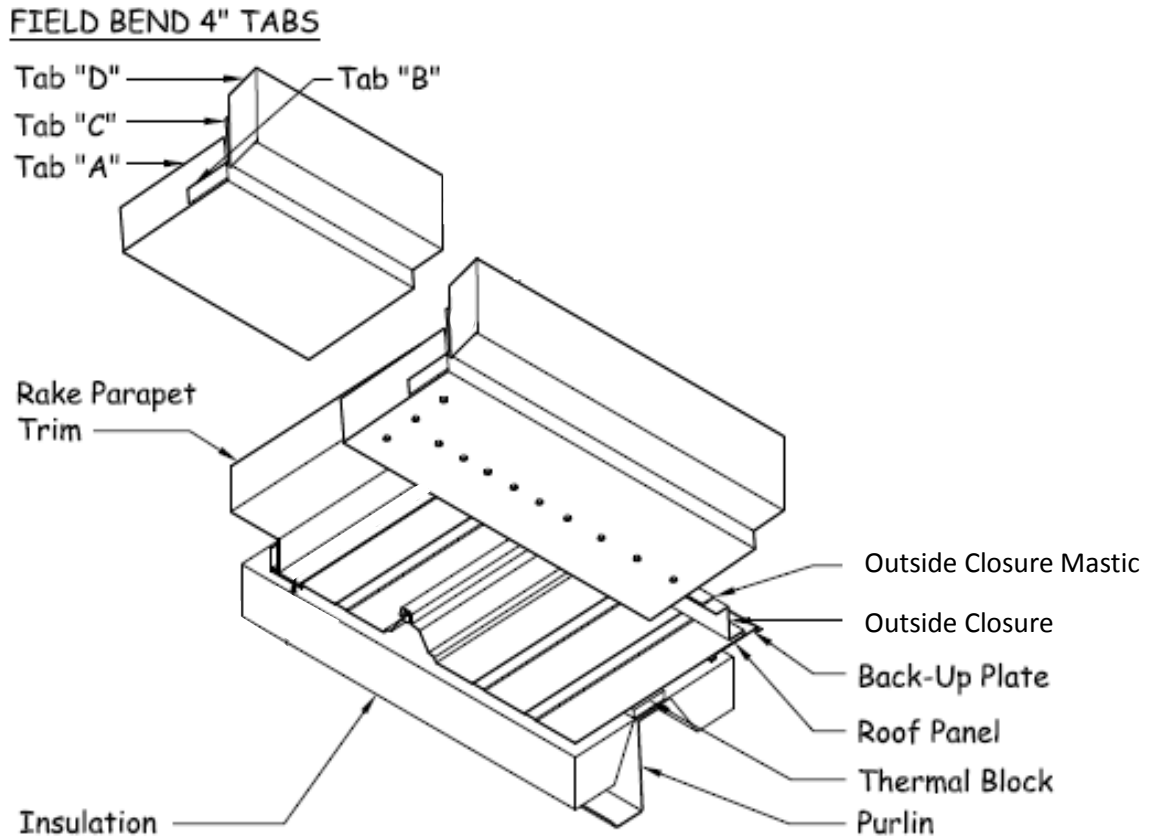

Apply the 1 ½" wide tape mastic (RS1) continuously across the top of the outside closures. Remove the paper backing **ONLY** as the work progresses.

**NOTE: FIELD MITERING IS REQUIRED BEFORE INSTALLING THE HIGH EAVE PARAPET TRIM.**

Scribe A LINE 4-INCHES IN FROM THE END OF THE HIGH EAVE PARAPET TRIM. Make a "through" cut at all bends to form tabs "A", "B", "C", and "D" as shown below. Bend tabs as shown above.

Apply tube caulk around the perimeter of all tabs and place the high eave parapet trim over the outside closures and fasten with five screws per each outside closure.

**The trim MUST be properly positioned BEFORE touching the mastic. Mastic cannot be reused.**

Refer to the erection drawing details for the high eave parapet trim attachment to the wall.



## 16.0 Roof Line Trim Installation

### 16.15 Standard Rake Parapet Transition Flashing to High Eave Trim Installation (Inside Corner)

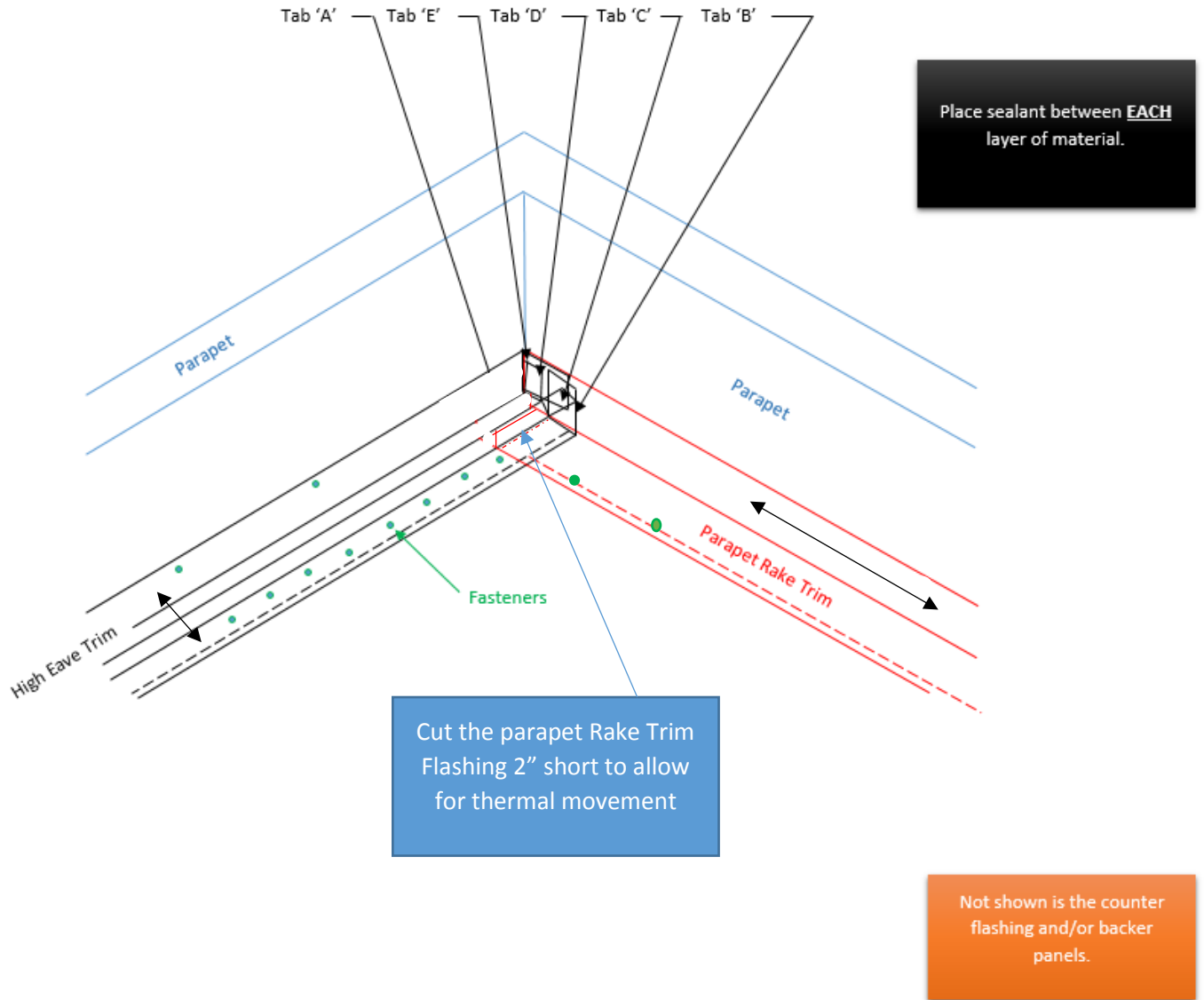

## 16.0 Roof Line Trim Installation

### 16.16 Standard Rake Parapet Transition Flashing to High Eave Trim Installation (Outside Corner)

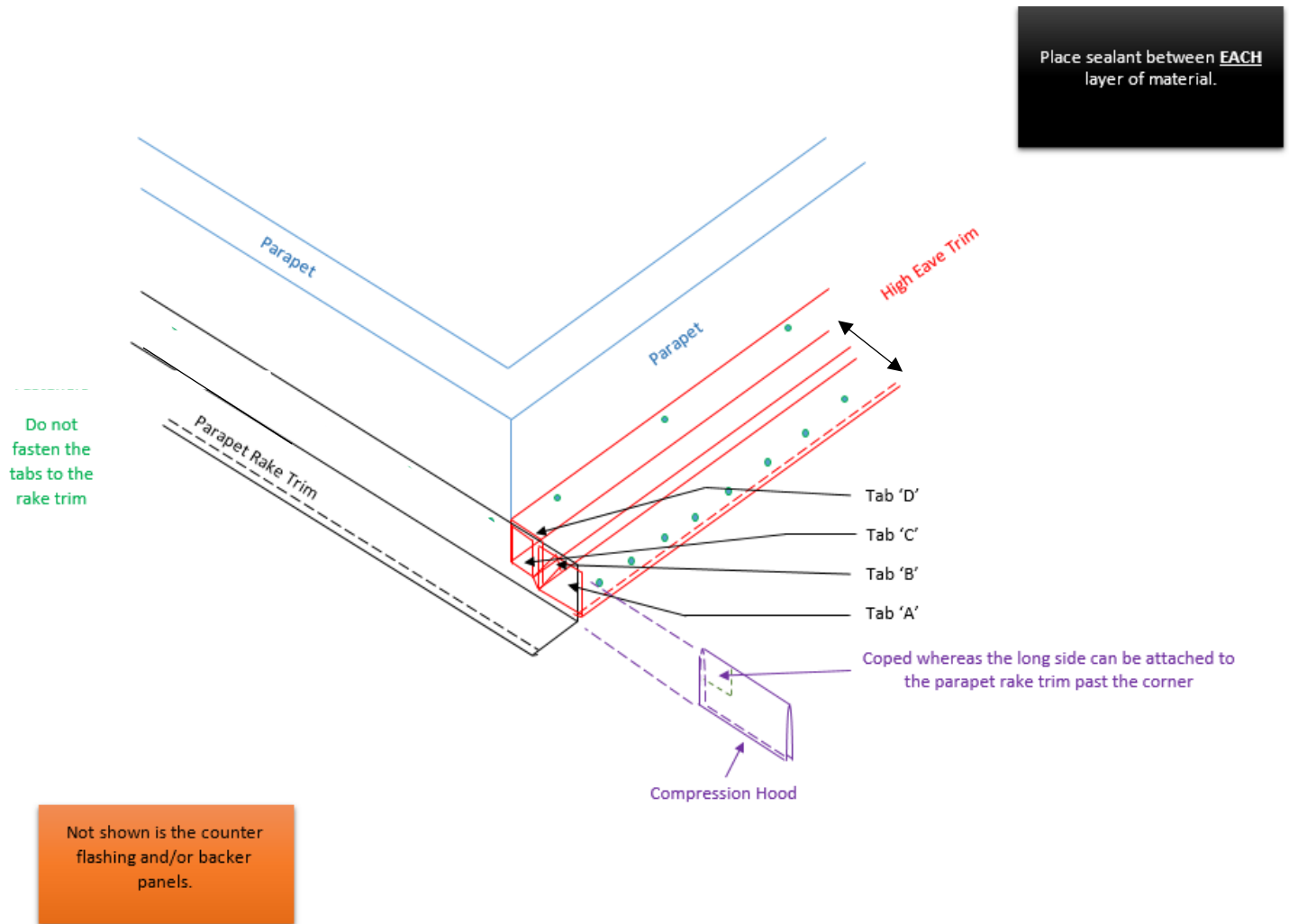

16.0 Roof Line Trim Installation

16.17 Lean-To to High Eave Rake Box Installation

LEAN-TO to HIGH EAVE RAKE BOX INSTALLATION

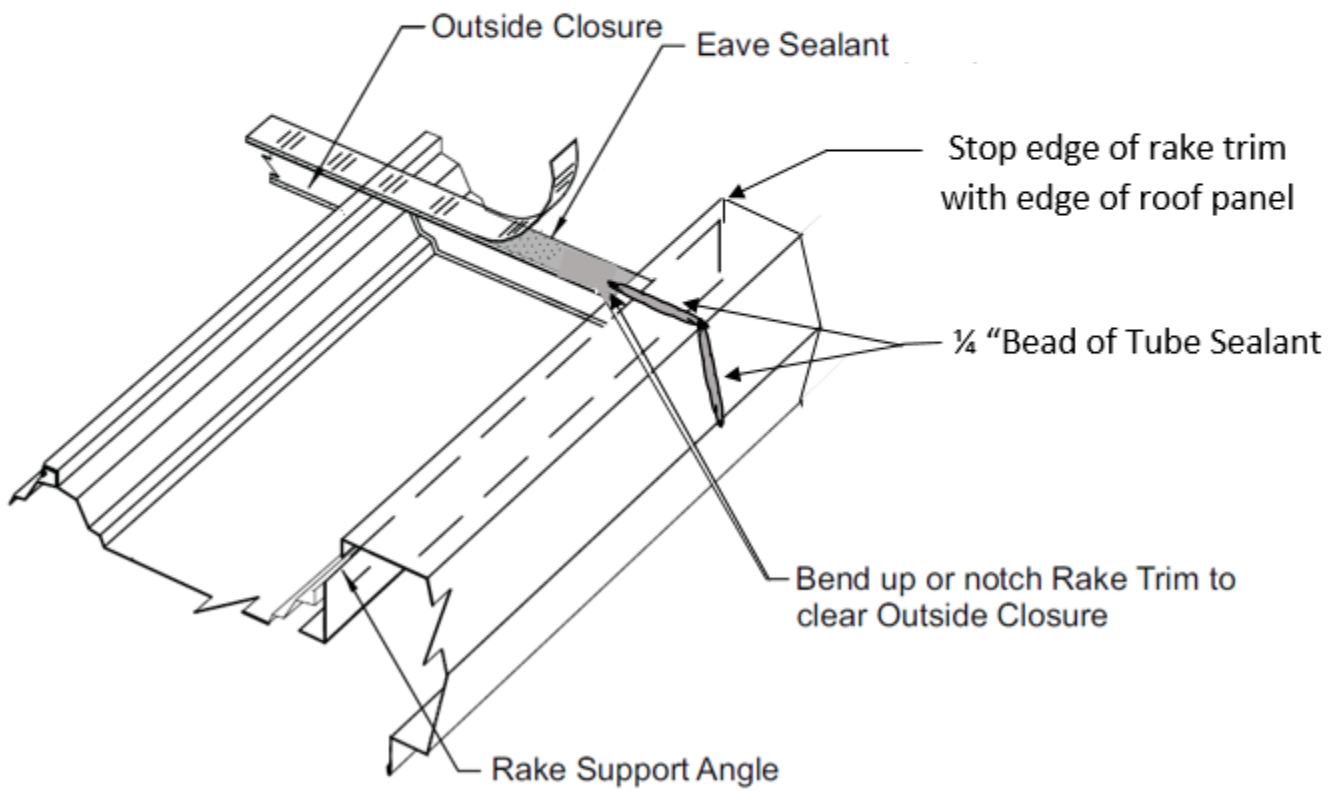

16.0 Roof Line Trim Installation

16.17 Lean-To to High Eave Rake Box Installation

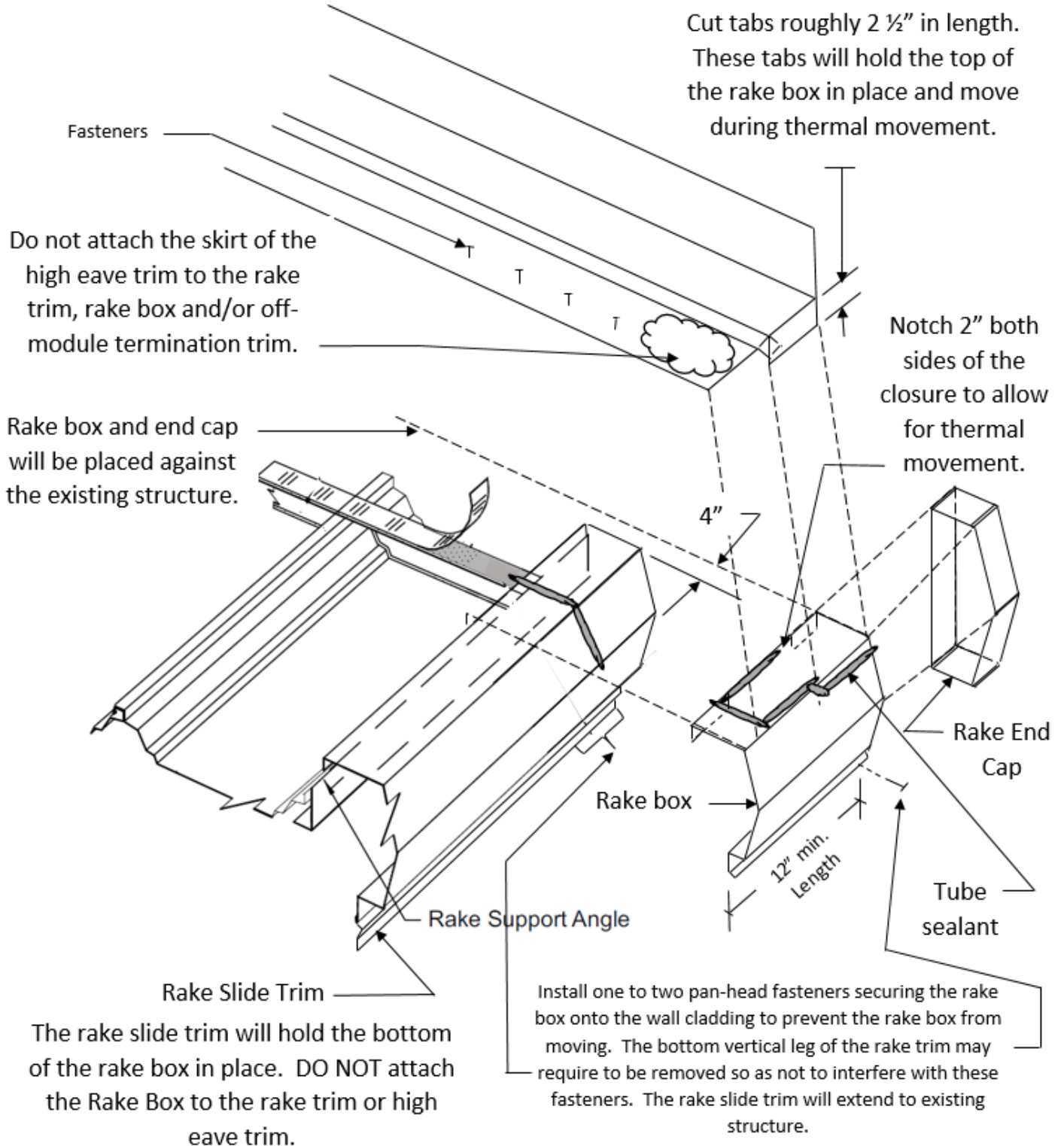

16.0 Roof Line Trim Installation

16.18 High Eave Parapet Trim Lap

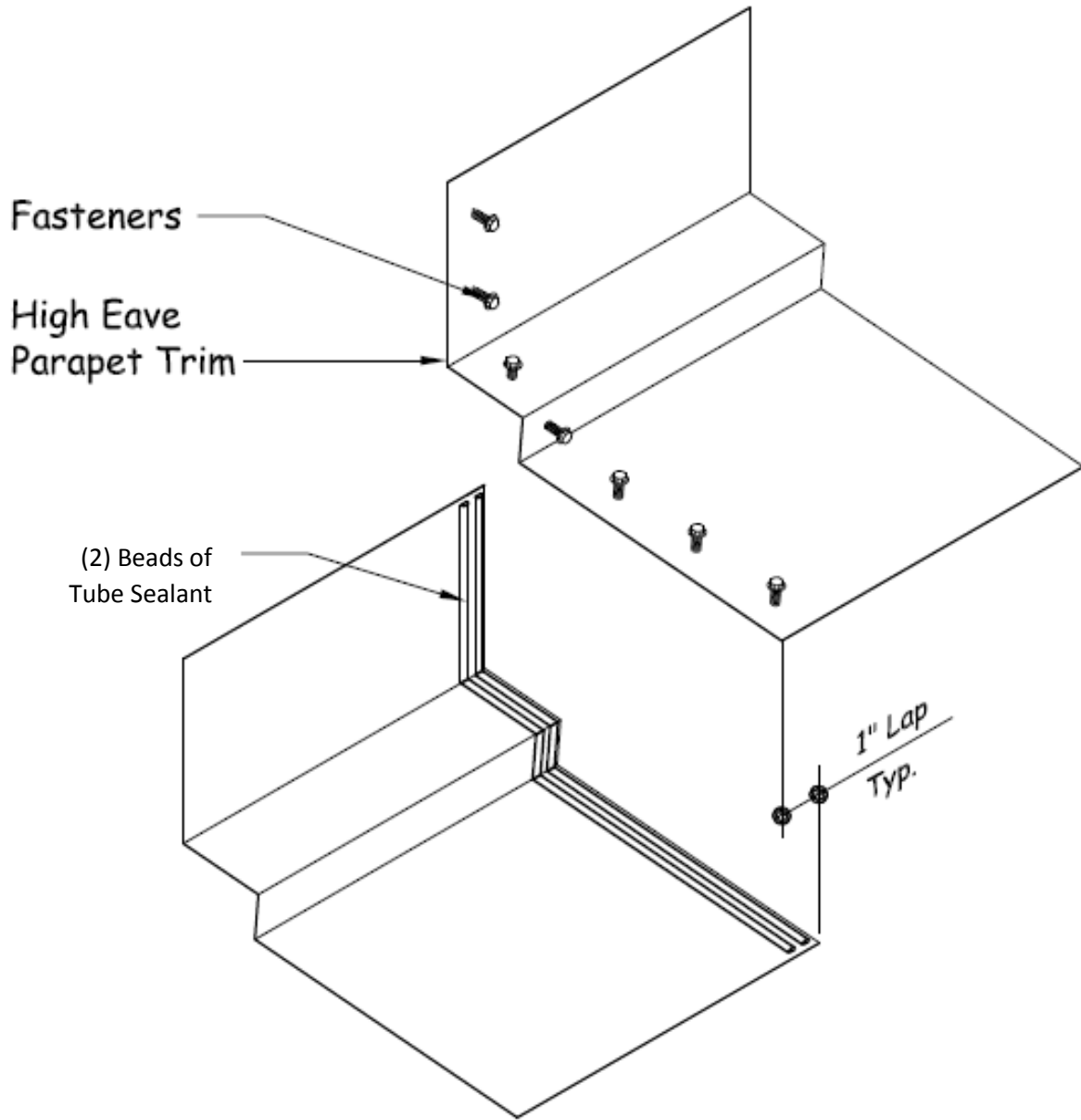

To lap the high eave parapet trim, apply (2) continuous beads of tube caulk to the end of the installed piece of trim.

Position the adjoining piece on top of the caulk, lapping 1-inch in length. Fasten with (7) trim-colored self-drilling screws.

Insure that the fasteners penetrate through the caulking.

## 16.0 Roof Line Trim Installation

### 16.19 Eave Gutter Installation

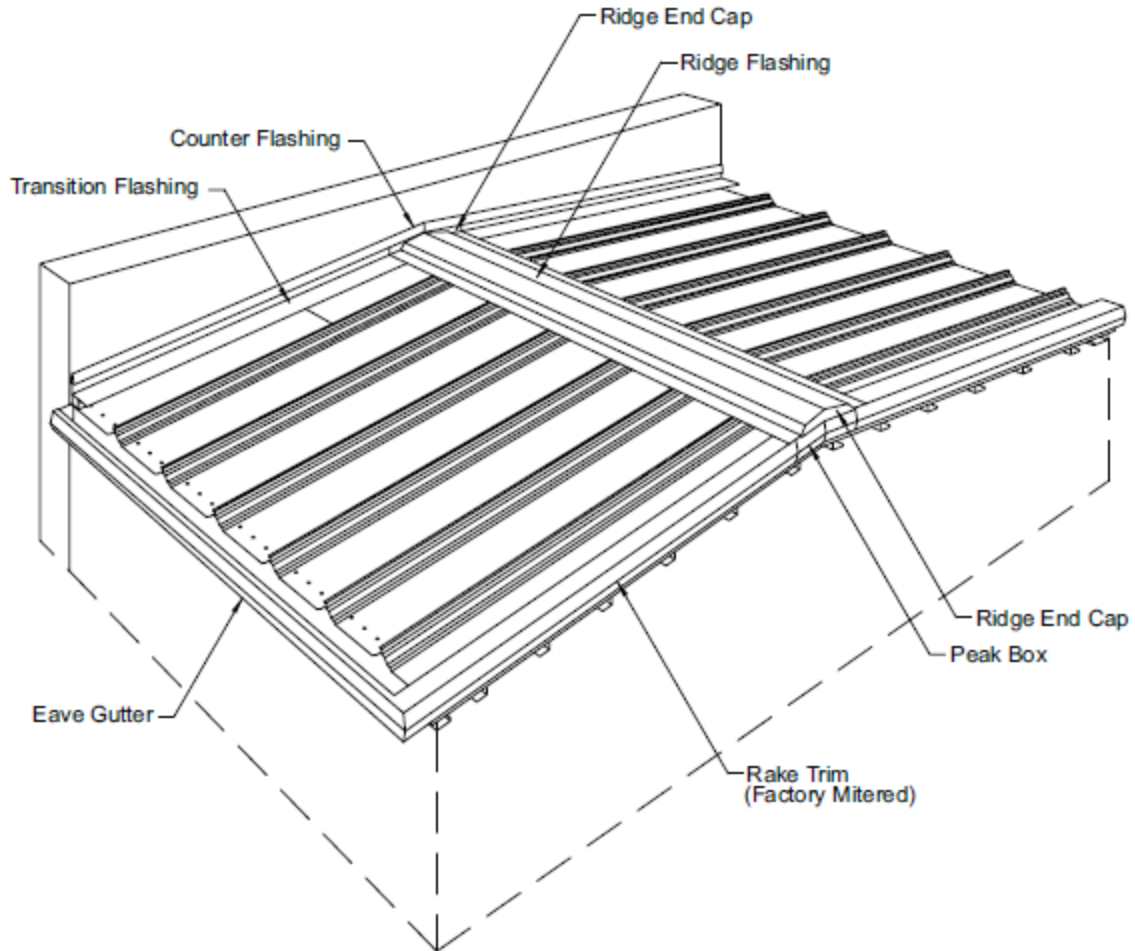

The details in this section show assembly and installation of the eave gutter.

Assembly of the gutter should be accomplished with care given to the final appearance. The appearance of the gutter will have a critical effect on the appearance of the project.

Determine which direction the building is most often viewed from. Install the gutter laps facing away from the most often viewed direction.

Proper downspouts are necessary to prevent gutter overflow and roof flooding. Refer to the erection drawings to determine the required downspout size and spacing.

## 16.0 Roof Line Trim Installation

### 16.19 Eave Gutter Installation

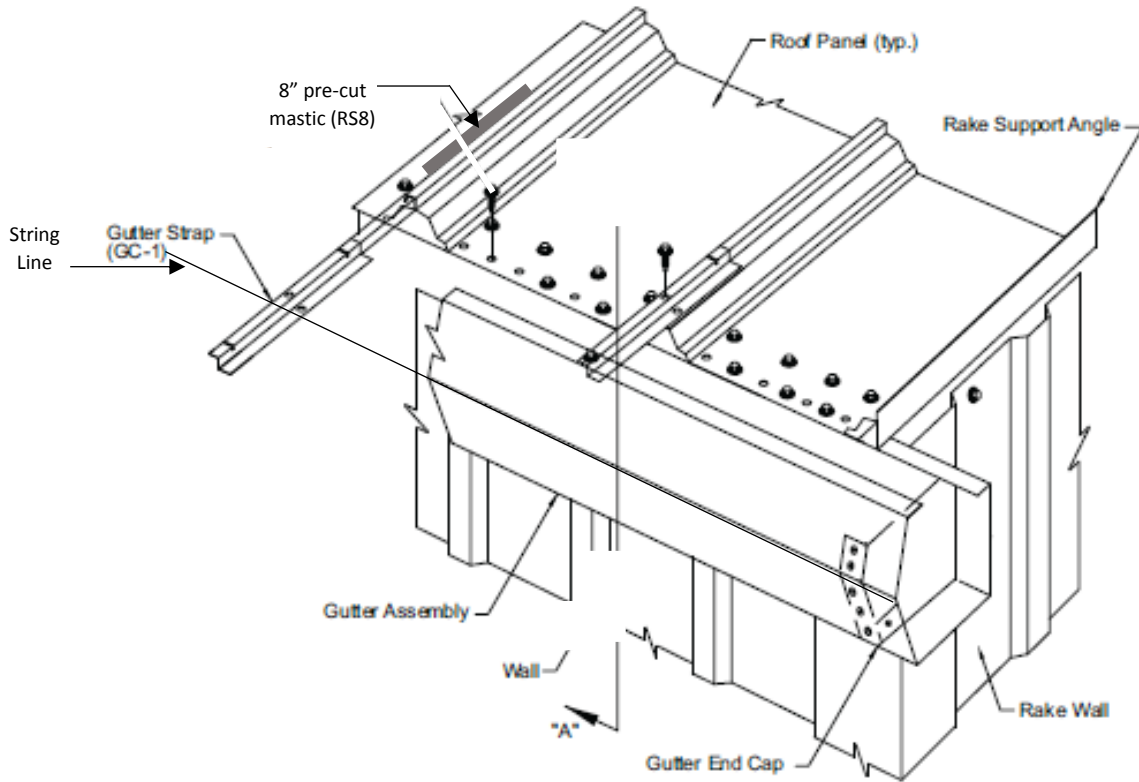

Establish a string line beyond the eave edge of the roof panel to aid in proper gutter bracket alignment.

Apply 8-inch pre-cut mastic (RS8) between the gutter bracket and roof panel rib.

**NOTE:** Before the gutter bracket can be installed, the panel seam at the low eave **MUST** be hand crimped. Place the gutter bracket on the roof panel, holding the low eave end at the string line.

**Gutter brackets are required at every other panel rib (48-inches O.C.)**

Fasten the gutter bracket to the panel rib with (2) self-drilling screws ensuring that the tape mastic has been penetrated.

16.0 Roof Line Trim Installation

16.20 Eave Gutter End Lap/End Cap Installation

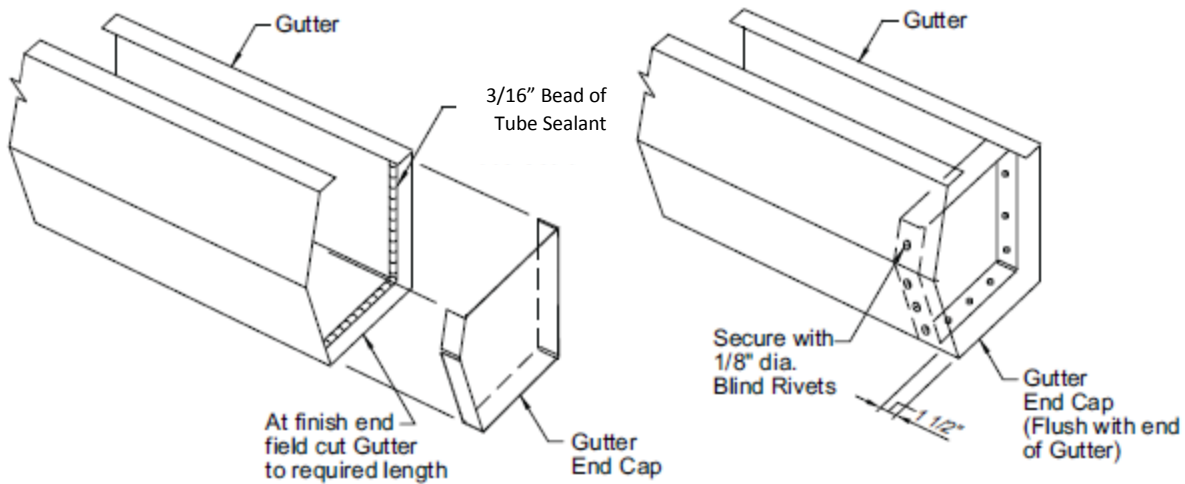
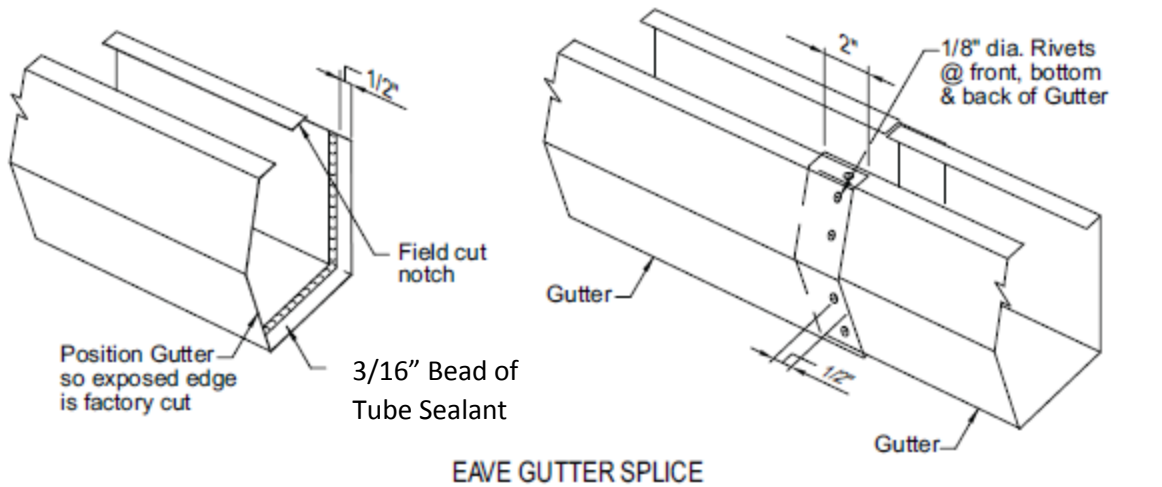

Layout the gutter assemblies in manageable lengths (30' to 40') before raising to the roof.

Start and finish the gutter ends flush with the exterior face of the rake walls.

Assemble the gutter end caps and splices with tube sealant and rivets as shown on the above details.

**ERECTION TIP:** Assemble lengths on the ground then with proper man power, slide the length under the eave and temporary clamp to eave overhand for fastening thru factory pre-punched holes.

Apply 1/2-inch wide tape mastic to the top side of the back hemmed lip of the gutter. (optional)



## 16.0 Roof Line Trim Installation

### 16.21 Eave Gutter Installation

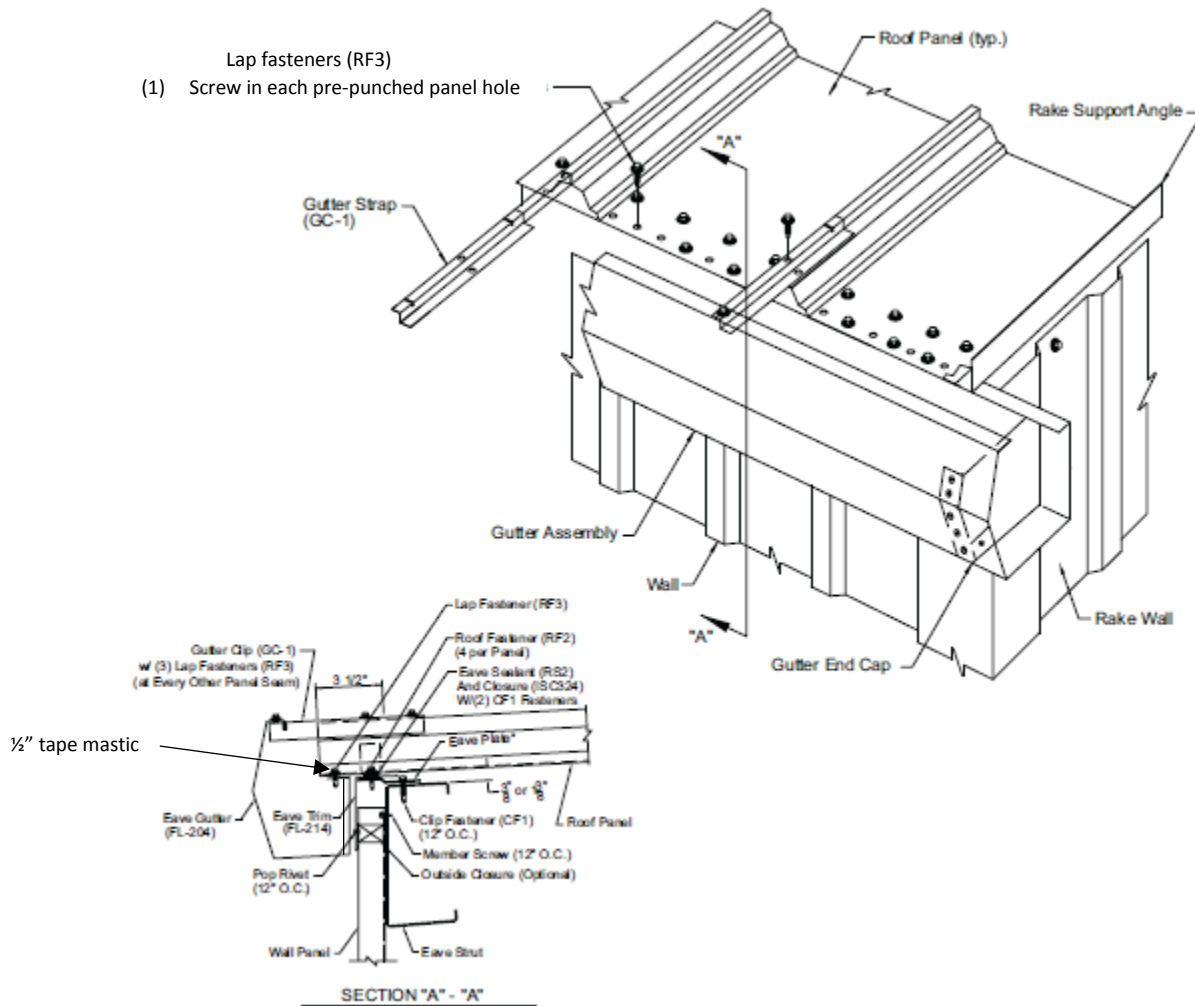

Lift the gutter assembly into position under the edge of the roof panels and temporarily clamp the back flange of the gutter to the roof panel. The back hemmed lip of the gutter will be in alignment with the roof panel's pre-punched holes.

The front of the gutter assembly can also rest upon the outside edge of the gutter brackets.

Fasten the gutter's back hemmed lip to the roof panel with lap fasteners (RF3). These (4) fasteners per panel will be located through the roof panel's pre-punched holes.

**THE BACK OF THE GUTTER WILL NOT BE FLUSH AGAINST THE FACE OF THE WALL PANELS.**

**NOTE: The gutter bracket should be under the front lip of the gutter and secured with a lap fastener (RF3).**

## 16.0 Roof Line Trim Installation

### 16.22 Eave Gutter/Rake Trim Installation

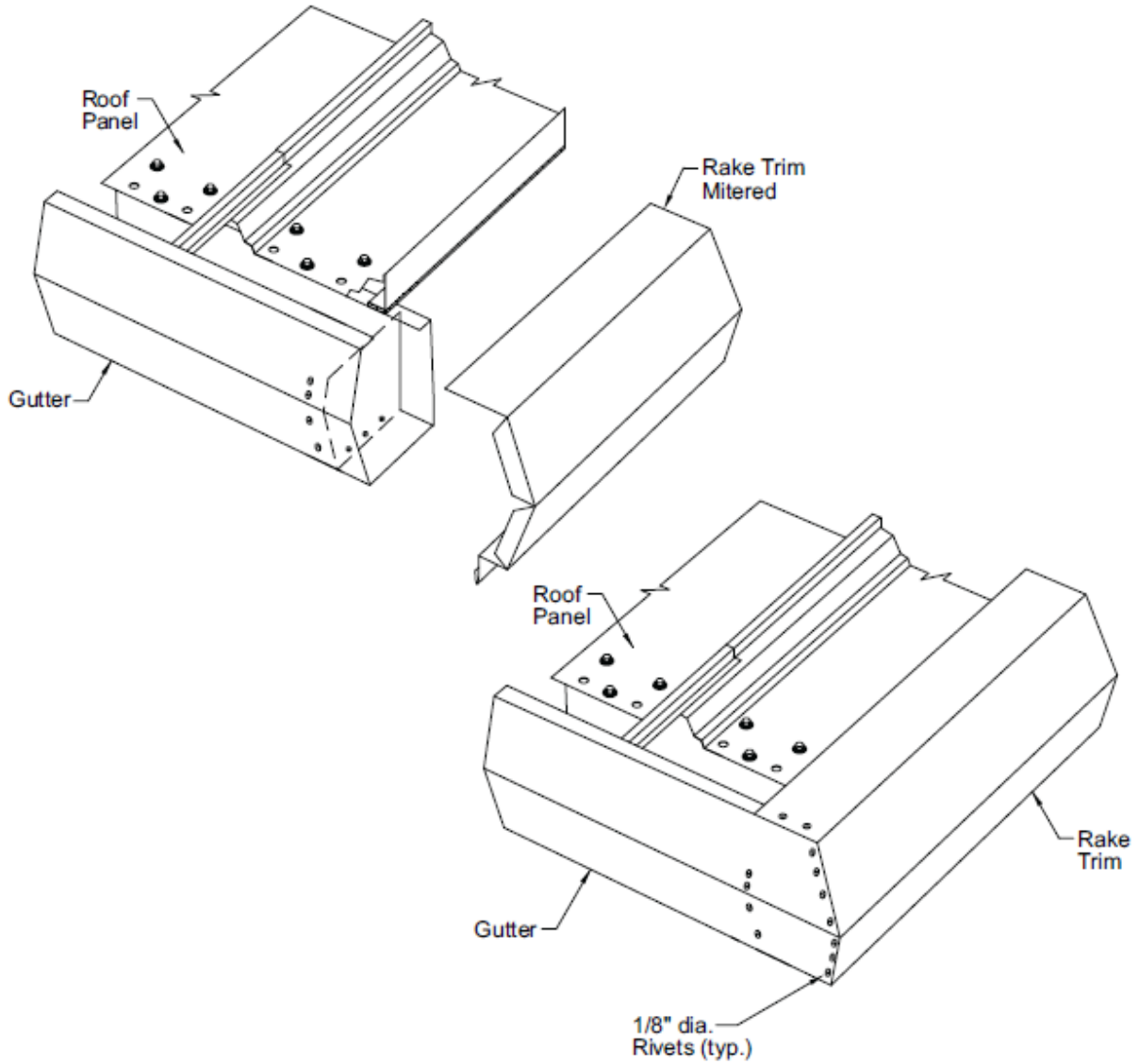

Check to make sure all edges are sealed with MS Polymer tube sealant.

Align the mitered edges and attach with 1/8" diameter pop rivets.

Insert the rake trim into the gutter.

## 17.0 Check List

The following check list is intended to assist the builder and/or erector in troubleshooting and punching out the Horizon TS-324™ Roof System. This list is not intended to serve as a certification of the roof system, because many details such as mastic installation are impossible to inspect after the roof has been erected. However, in conjunction with continuous quality control measures during the erection process, this list should help insure a safe, weather tight roof system.

Horizon recommends that detailed notes be taken during the inspection and punching out the roof. The erector or the actual person doing the work should have access to these notes. Do not place pencil markings on the Galvalume panels, because the pencil lead will cause rusting and will void your Galvalume warranty. Instead, consider using clothes pins attached to the seam of the panel to point out problem/unfinished areas. These work well, do not create a mess, and can be seen from across the roof.

### 17.1 TS-324 Roof Detail Compliance List

#### LOW EAVE CONDITION

- Y N Is the first bend in the eave plate aligned with the edge of the eave strut or other roof member?
- Y N Does the eave plate extend all the way to the end wall steel line?
- Y N Is the eave plate fastened to the eave strut at 12-inches O.C.?
- Y N Is mastic applied continuously along the top of the eave plate?
- Y N Has the 3-inches pre-cut mastic been installed on the low eave panel rib prior to the next panel being installed?
- Y N Is the insulation visible at the eave plate (from the outside)? (If so, this is not correct.)
- Y N Are there two fasteners installed through each of the void closure?
- Y N Is the space around and above the void closure properly sealed with mastic and/or tube caulk?
- Y N Are the gutter support brackets installed 48-inches O.C.?
- Y N Are there four fasteners installed into the flat of the panel at the low eave?

#### RAKE CONDITION

- Y N If the building has insulation, does the insulation extend to the rake support angle and/or steel line?
- Y N Are the rake trim fasteners installed 12-inches O.C.?
- Y N Is the base of the rake trim allowed to float inside the slide trim?

#### END LAP CONDITION

- Y N Is the end lap mastic properly placed between the laps?
- Y N Does the end laps have a back-up plate with ALL four tabs engaged?
- Y N Has the end lap tube caulk been properly placed up-slope and adjacent to the tape mastic?
- Y N Are the back-up plates properly engaged by the fasteners?
- Y N Are there any stripped or missing fasteners at the panel end laps?
- Y N Are all over-sized fasteners properly tightened?
- Y N Are there four fasteners installed at the end lap?
- Y N Has the cinch strap been installed?

#### Panel Side Lap Condition

- Y N Are all panel side laps properly hooked?
- Y N Can you see insulation or paper tabs protruding from the side laps? (If so, this is not correct.)
- Y N Are the two fasteners per panel clip spread out as far as possible? Avoid placing fasteners side by side.
- Y N Has all the roof seams been hand crimped into a TripleLok seam profile – as a minimum?
- Y N Are the FINAL roof seam type utilized and completed per design? (TripleLok or QuadLok)

## 17.0 Check List

### RIDGE OR HIGH EAVE CONDITION

- Y N Has the 3-inch pre-cut mastic been installed on the high side panel before the next panel has been installed?
- Y N Has the Butyl standing seam tube caulk been installed up-slope and adjacent to the tape mastic?
- Y N Is the outside closure mastic placed properly?
- Y N Is the 3-inch pre-cut mastic being placed over the notch area at the ridge/high eave before the outside closure is being installed?
- Y N Is the panel seam notched to receive the outside closure?
- Y N Were the outside closures installed as the roof was being erected for proper coverage and alignment?
- Y N Was mastic installed on top of the closures?
- Y N Was the 3-inch pre-cut mastic applied over the panel notch and butt joint of the closures?

Is the ridge cap installed properly, including:

- Y N Was caulk applied at the ridge cap end laps?
- Y N Is there five fasteners used to install the ridge cap to EACH closure?
- Y N Do not install fasteners at the ridge cap end laps?

### GENERAL CONDITION

- Y N Are the roof panel runs installed straight?
- Y N Are there any damaged panels installed?
- Y N Are perimeter clips installed? (If required)
- Y N Are the panel clips attached to the purlins or bar joists with two fasteners?
- Y N Are there clip fasteners seen at EVERY panel side lap and purlin/joist intersecting point?
- Y N Has all pencil lead and markings been cleaned from the panels?
- Y N Have all metal shavings, dirt, etc., been cleaned from the roof?
- Y N Are the HVAC units draining into the gutter with PVC piping?
- Y N Has the roof curb framing/flashing been installed properly?
- Y N Has treated lumber been avoided as a means of supporting piping and other roof accessories?
- Y N Are the downspouts been properly spaced according to the erection instructions?
- Y N Are the downspout openings in the gutter cut to the proper size to allow for adequate water drainage?
- Y N If the TS-324 is being installed over a non-Horizon structure, has the Engineer of Record reviewed the purlins for adequate bracing?
- Y N Have lead, iron or copper pipes been coated or painted to protect against corrosion with the Galvalume?

**DUE TO THE PROCESS OF CONTINUOUS IMPROVEMENT, THE  
PRODUCTS AND PROCEDURES IN THIS MANUAL ARE SUBJECT TO  
CHANGE WITHOUT NOTICE**